



# **FARM MACHINERY AND PROCESS MANAGEMENT IN SUSTAINABLE AGRICULTURE**

## **II International Scientific Symposium**



II International Scientific Symposium

**FARM MACHINERY AND PROCESS  
MANAGEMENT  
IN SUSTAINABLE AGRICULTURE**

*Symposium Proceedings*

Edited by

Bruno Huyghebaert, Edmund Lorencowicz, Jacek Uziak

Published by

Walloon Agricultural Research Centre

**Gembloux, Belgium 2007**

## **Organizers**

Department of Machinery Exploitation and Management in Agricultural Engineering, Agricultural University in Lublin, POLAND  
Walloon Agricultural Research Centre, Gembloux, BELGIUM

## **Organizing Committee**

### Chairmen

Prof. dr hab. Józef Sawa, Agricultural University in Lublin, Poland  
Prof. dr Yves Schenkel, Walloon Agricultural Research Centre, Belgium

### Members

Prof. dr Philippe Burny, Walloon Agricultural Research Centre, Belgium  
Ir. Bruno Huyghebaert, Walloon Agricultural Research Centre, Belgium  
Dr inż. Magdalena Kachel-Jakubowska, Agricultural Univ. in Lublin, Poland  
Dr inż. Sławomir Kocira, Agricultural University in Lublin, Poland  
Dr inż. Milan Koszel, Agricultural University in Lublin, Poland  
Dr hab. Edmund Lorencowicz, Agricultural University in Lublin, Poland  
Dr Olivier Miserque, Walloon Agricultural Research Centre, Belgium  
Dr inż. Stanisław Parafiniuk, Agricultural University in Lublin, Poland  
Prof. dr Jacek Uziak, University of Botswana, Botswana

ISBN 979-2-87286-056-2

Registration of Copyrights D/2007/1463/5

*Cover page:* Sławomir Kocira, Magdalena Kachel-Jakubowska

*Illustration on cover page based on motif from painting "Orka" by Józef Chełmoński*

*All papers are published on the responsibility of authors and after the positive reviewing by the Symposium Organizing Committee.*

*Printed by:* Reprographic Centre, Agricultural University in Lublin

The organizers wish to acknowledge with thanks the  
sponsorship and support of

**Rector of the Agricultural University in Lublin, Poland**

**SIPMA SA Company**



**Media Sponsor ??? ???  
Farmers Journal – Agricultural Machinery Review**



## CONTENTS

Introduction	... 7
Recent changes of the farm structure and mentalities in Kujawy&Pomorze Province <i>Waldemar Bojar, Grzegorz Dzieża</i>	... 9
Monitoring system of sugar beet production <i>Małgorzata Bzowska-Bakalarz, Katarzyna Gil</i>	... 11
Input balancing in sustainable agriculture using computer technologies <i>Michał Cupiał, Sylwester Tabor</i>	... 17
Changes in technical equipment and European Union grants in chosen farms of Lublin Province <i>Jarosław Figurski, Edmund Lorencowicz</i>	... 21
Contribution of regional signalization and warning system for pests and diseases infestation to sustainable agricultural <i>Maciej Gałęzewski</i>	... 27
Economic analysis of energy management options of plant production systems <i>Duane Griffith, Edmund Lorencowicz</i>	... 31
The effect of updating selected operational-economic indices on the operation costs of new-generation farm tractors <i>Zenon Grześ</i>	... 37
Comparative study of the precision of six GPS guiding systems in agriculture <i>Bruno Huyghebaert, Gaetan Dubois, Pascal Bienfait</i>	... 41
Determination of optimum timing for chemical control of cutworms using light traps and pheromone traps <i>Magdalena Jakubowska</i>	... 47
Assessment of the technical infrastructure according to the level of development <i>Zuzanna Jarosz</i>	... 51
Agricultural technologies and work safety <i>Tadeusz Juliszewski</i>	... 57
Biomass potential in the area of Lublin Province <i>Magdalena Kachel-Jakubowska</i>	... 61
Influence of working parameters on spray quality of air inclusion nozzles <i>Milan Koszel</i>	... 67
The influence of annual use of bucket milking machines on their operating prevention <i>Witold Kowalik</i>	... 71
Assessment of farm sustainability level as a function of the agricultural production profile <i>Stanisław Krasowicz</i>	... 75
Warehousing potential and its use by specialized farms <i>Maciej Kuboń</i>	... 79
Ground stress modeling <i>Aleksander Kuzmitsky, Georgiy Betenja</i>	... 83
Effectiveness of mechanization on energy Willow cultivation <i>Dariusz Kwaśniewski</i>	... 89
Organization of mechanization in selected family farms <i>Edmund Lorencowicz, Jacek Uziak</i>	... 93

Technical equipping indicator and work efficiency in relation to simplification of plant production <i>Urszula Malaga-Tobola</i>	... 97
Placing plant protection products on the Polish market with regard to the registration of individual formulations <i>Ewa Matyjaszyk</i>	... 101
The assessment of production sustainability in farms on the base of nitrogen, carbon and organic matter balance <i>Kazimierz Piekut, Mirosław Machnacki</i>	... 107
Droplets size measurement by electrostatic method applied to agricultural nozzles <i>Dariusz Plichta</i>	... 115
Field trials on grain maize cultivation technologies in 2004, 2005 and 2006 <i>Petr Šařec, Ondřej Šařec, Katarzyna Gil</i>	... 121
Estimation of indicators for sustainable agricultural production <i>Józef Sawa</i>	... 127
Development of a testing device for spraying nozzles <i>Józef Sawa, Stanisław Parafiniuk, Joanna Tarasińska, Bruno Huyghebaert</i>	... 129
The time of establishing the moisture content in the mixture of organic materials <i>Marek Ścibisz</i>	... 135
Mechanization individual farms on Opolskie Province <i>Tomasz Szuk</i>	... 137
Variety and species mixtures of cereals as the alternative for sustainable and ecological farming <i>Anna Tratwal</i>	... 143
The relation between mechanical damage to (witlof) chicory roots during harvesting and the occurrence of <i>Phoma exigua var. exigua</i> during forcing <i>Jurgen Vangeyte, Jeroen Baert, Willem Maertens, Christel Van Ceulebroeck, Wim Hubrechts, Bart Sonck</i>	... 147
Study, design and development of a low-budget prototype harvesting machine for Roman Chamomile <i>Jurgen Vangeyte, Joris Baro, Jonas Rijckaert, Koen Vanden Haute, Wim D'Haese, Bart Sonck</i>	... 153
Pressure measurements on concrete walls of farms trench silos <i>Annelies Van Nuffel, Jurgen Vangeyte, Jeroen Baert, Willem Maertens, Bart Sonck</i>	... 159
Assessing farm sustainability: evidence from Flemish dairy farms <i>Steven Van Passel, Marijke Meul, Frank Nevens</i>	... 165
Structure model of information system for identification and analysis of logistics costs for farms <i>Karol Wajszczuk</i>	... 171
Indicating an optimal time of <i>Oulema</i> Spp. chemical control on cereals <i>Felicyta Walczak</i>	... 177
Management of sewage sludge in SBR sewage treatment plants <i>Zbigniew Wasąg</i>	... 183
Keyword index	... 189

## **INTRODUCTION**

Effective agriculture is commonly based on intensive farming using the industrial methods of production. Such farms apply the scientific and technical progress without any complex evaluation of its effects. The purpose of such Agriculture is the maximization of the yield, production and profit. These objectives are realized above all through a systematic increase of the material and energetic expenses.

The economic dynamics of European farms has changed completely during these recent years. Therefore, the concept of high quality production - sustainable agriculture - was introduced a few years ago. Hence, a kind of re-orientation of agriculture can be observed and new concepts of production and management have been introduced; these are integrated production, Good Agricultural Practice and Sustainable Agriculture. Agriculture is no more considered as being only a production tool. Its socio-cultural and environmental role is more and more taken into account.

Rational management of agricultural technology is the most important element of every system of agricultural production. We trust that the second symposium "Farm Machinery and Process Management in Sustainable Agriculture" will be a good platform to exchange ideas and will contribute to a better comprehension of the "Sustainable Agriculture", as part of "Sustainable Development", and putting its principles into practice.

*Organizers of Symposium*

## **RECENT CHANGES OF THE FARM STRUCTURE AND MENTALITIES IN KUJAWY&POMORZE PROVINCE**

*Waldemar Bojar, Grzegorz Dzieża*

*Bydgoszcz Univeristy of Technology and Life Sciences, Faculty of Management, Bydgoszcz, POLAND*

*e-mail: wald@utp.edu.pl*

**Keywords:** farm changes, human resources, farm mechanization

### **Abstract**

#### **Goal and method**

Paper presents tendencies of changes in resources and forms of cooperation occurring in farms in Kujawy & Pomorze Province.

The survey of farms was made on a basis of questionnaires completed by farmers and interviews with the management of the regional refrigeration plant which had cooperation agreement with the farms. The survey was based on the group of 76 farms in 2001, 80 - in 2004 and 66 farms in 2006. During the analyzed period, there were essential changes in the sample of farms cooperating with the refrigeration plant, hence formulated conclusions concerning dynamics of changes on farms requires cautious approach.

#### **The findings**

The findings show a growth of the average farm size from 15.56 ha to 17.55 ha between 2001 and 2004. It has to be considered as a positive adjustment process of the farms realized through the increase of the production scale. Between 2001 and 2004, no significant change in the farmers' age has been noticed. But positive progress in the farmers' skill have been observed considering that the part of farmers having secondary and tertiary level of education increased. Such phenomenon can also be considered as an improvement of intellectual capital of rural society represented by the farms considered in the research.

The analysis of the machinery purchased by farmers between 1994-2000 shows that the tractors and sprayers constitute the main investment for all surveyed farms regardless of their size. This fact can be partly explained by the relative low prices of the sprayers and the great number of second-hand tractors bought by farmers. Other findings confirm that the depreciation of farm equipment in Poland and also in Kujawy & Pomorze Province is essential (Wójcicki 1998, 2002', 2002'', 2003).

A lack of investment concerns particularly the harvesting machines. For example, the investment share dedicated to combine reaches hardly 3.9 per



cent. These facts were long-established by other research findings. For the last decade Poland has suffered from the lack of replacement of combine harvesters: on average only 3.1 to 11.8 units for 1000 combine in use have been replaced, while in Germany these values range from 17.3 and 25.3, in France 12.4 to 26.5 and in U.S. 10.2 to 19.1 (Takács, Bojar 2003). The increasing value of the EU financial measures dedicated to farm investments gives hope for the better perspective for the modernization of farm equipment.

The level of cooperation declared by farmers in the form of common usage of machinery, buying production means and also preparing common market offers is not sufficient. The understanding of the necessity of such cooperation increases with the level of education level of farmers and the size of the farm. It can be connected to their market orientation. Though, there is a positive aspect of increasing consciousness of farmers to build sustain forms of mutual cooperation. However, long-term co-operation with local and council government administration is still rarely realized.

## **Conclusions**

The process of changes observed in the selected farms of Kujawy & Pomorze Province shows that there are positive tendencies concerning intellectual capital, farm land area and farm technical equipment. The co-operation between farmers and farmers with public is not sufficiently developed and it should be intensified.

## **References**

- Wójcicki Z. 1998. Wyposażenie rolnictwa w środki techniczne – stan i kierunki przemian w układzie sektorowym i regionalnym, IBMER, Warsaw, Poland, 125 p.
- Wójcicki Z. 2002. Prognostyczne modele rozwoju rolnictwa i techniki rolniczej. *Probl. Inż. Rol.* 2002 Vol.10 No 2, pp. 15-24.
- Wójcicki Z. 2002''. Projektowanie technologii produkcji w gospodarstwach rodzinnych. *Wiś Jutra* 2002 No 1(42), pp. 30-33.
- Wójcicki Z. 2003. Modernizacja rozwojowych gospodarstw rodzinnych, *Prace Naukowe Akademii Ekonomicznej we Wrocławiu* No 983, pp. 537, 541, 543.
- Takács I., Bojar W. 2003. Challenges and Opportunities for Agriculture of Central Europe According to Farm Structure and Abounding with Capital. 14<sup>th</sup> International Farm Management Congress, Sydney, pp. 935-941.

## **MONITORING SYSTEM OF SUGAR BEET PRODUCTION**

*Malgorzata Bzowska – Bakalarz, Katarzyna Gil*  
*Agricultural University in Lublin, Department of Agricultural Machines Theory,*  
*Lublin, POLAND*  
*e-mail: malgorzata.bzowska@ar.lublin.pl*  
*katarzyna.gil@ar.lublin.pl*

**Keywords:** sugar beet, production system, decision support software

### **Introduction**

In the current state of sugar surplus and sinking reference prices in EU countries, sugar production is limited by regulations of the Community and member states level. The EU sugar beet acreage has been significantly reduced (Table 1) and will further decrease due to withdrawal of 13.5% of quota sugar from the market during the 2007/2008 marketing year. (Commission Regulation (EC) No 290/2007). The minimum beet price for quota beets will be reduced from EUR 32.86 per tonne to EUR 26.29 per tonne within the next four years (Council Regulation (EC) No 318/2006). Sugar payments will compensate only a fraction of the beet growers' losses (Council Regulation (EC) No 319/2006). Therefore, efficient beet growing methods that provide high yields and best quality are vital if beet production is to stay economical. Especially in Poland, the variety of sugar beet growing methods used in practice is so high, that their careful analysis in terms of efficiency is advisable (Bzowska-Bakalarz et al. 2005, Przybył et al. 2004, Szeptycki 2005). The comparison of the results of different sugar beet production methods and techniques can be used to improve growing processes (Bzowska-Bakalarz et al. 2005).

Poland, although the third biggest sugar producer in the European Union, generates significantly lower beet yields and sugar yields per hectare than other member countries (Table 1). This can be attributed mainly to mistakes in beet growing – namely in after-harvest cultivation, fertilising, autumn and spring soil preparation, sowing, plant protection and harvesting (Bzowska-Bakalarz et al. 2003).

Table1. Sugar beet acreage and sugar beet yields of some EU countries

Country	2006/07	2005/06		
	Sugar beet acreage (ha)	Sugar beet acreage (ha)	Sugar beet yield (t/ha)	Sugar yield in t raw sugar value/ ha harvested
Germany	365 000	418 820	60.4	10.5
France	302 000	340 215	82.0	13.4
Poland	260 000	277 979	44.3	8.0
Great Britain	114 000	125 900	69.0	11.6
Spain	101 000	102 000	77.0	11.6
Czech Republic	50 000	63 170	54.3	7.6

Source: (Cukier i Skrobia 2007)

Computer programmes are becoming useful as practical decision support tools for the growers. Many of these are advanced applications that provide recommendations on fertilising (NawSald), support choice of cultivation methods (Agroefekt), or advise on plant variety selection according to geographic region of the country (Fenologia Kukurydzy for maize growing) (Zalewski, Pietruch 2006). Some programmes are dedicated strictly to sugar beet growing. For instance, *Model procesu produkcji buraków cukrowych* (Przybył et al. 2002) is a programme that facilitates analysing various growing methods and selection of optimal variant, allowing for available means. Common and adequate tools for collection and processing of agricultural data are Microsoft Office applications (Šařec 2007).

As for improvement of the raw material supply system for a sugar plant, availability of information on the raw material supplier's production systems is considered a crucial factor. To prepare a corresponding support tool, the authors created a database in Microsoft Access that enables the user to analyse equipment used by growers, compare yields, assess agricultural methods and recommend the best growing method. The data is collected by means of questionnaires or Field Cards.

## Methods

The survey covered the supply base of one of the sugar plants in Lublin region. The growers to be questioned were selected by the supplies department specialists of the sugar plant; these were chosen among the growers intending to continue growing sugar beets in a number of years to come.

The questionnaire consists of three parts, and questions concern each of the vital points of the sugar beet growing process.

The structure of the database is presented in Figure 1. The main table *Ankieta* (Questionnaire) is connected by type one-to-many relationship with five subordinate tables: *Nawozy NPK* (NPK Fertilisers; information on NPK and magnesium used), *Nawozy pod międzyplon* (Fertilisers for Intercrop; this contains information on NPK fertilisers and magnesium used for stubble

intercrop), *Mikroelementy* (Microelements), *Herbicydy* (Herbicides), *Maszyny* (Machinery; information on technical equipment and facilities at the growers' disposal).

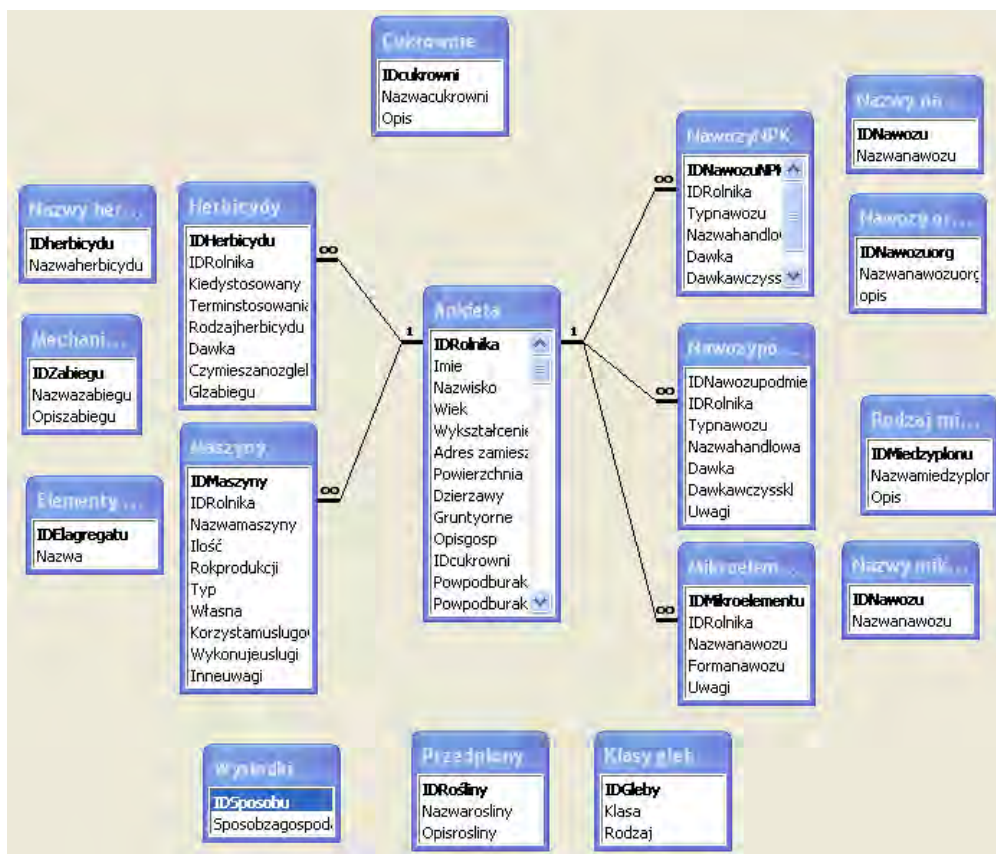

Figure 1. Structure of the database (screenshot)

Based on the main table, an enquiry form was developed to serve as the user's interface to input and modify data. The components of the *Ankieta* form are forms derived from subordinate tables. Moreover, the system contains nine additional tables, containing sets of answers to choose: *Cukrownie* (Sugar plants), *Elementy agregatu* (units of cultivation aggregate for spring soil preparation), *Klasy gleb* (Soil valuation class), *Mechaniczne zabiegi uprawy jesiennej* (Processes of autumnal mechanical cultivation), *Rodzaj międzyplonu* (Type of intercrop), *Nazwy herbicydów* (Herbicide types), *Nawozy organiczne* (Organic fertilizers), *Nazwy mikroelementów* (Microelements) i *Wysłodki* (Pulp). These tables are to facilitate the input of data. Data extracting was facilitated by introducing search queries.

The database reports generate clear lists of data required by the user. These present input information and also allow the user to list results of calculations made on the basis of inputs.

## Results

In order to verify the database operation, data collected in 2005 were input and processed. Figure 2 presents one of the database reports: a list giving a percentage of growers that fulfil a particular requirement stated by the sugar plant. The report is based on a search query selecting data within the main table.

The growers survey data of 2005 processed by means of the database were compared with the results of survey held in 2003 (Bzowska – Bakalarz 2003) and concerning the 2002/2003 marketing year, where data was processed manually.

Percentage of growers						
knowing soil reaction	testing soil samples to determine fertiliser dose	growing intercroops	documenting growing processes	keeping cost records	knowing final plant density	Number of roots per hectare
No	<input type="checkbox"/>	<input type="checkbox"/>	<input type="checkbox"/>	<input type="checkbox"/>	<input checked="" type="checkbox"/>	76580
Yes	<input checked="" type="checkbox"/>	<input type="checkbox"/>	<input checked="" type="checkbox"/>	<input checked="" type="checkbox"/>	<input checked="" type="checkbox"/>	86280
No	<input type="checkbox"/>	<input type="checkbox"/>	<input type="checkbox"/>	<input type="checkbox"/>	<input checked="" type="checkbox"/>	75600
Yes	<input checked="" type="checkbox"/>	<input checked="" type="checkbox"/>	<input type="checkbox"/>	<input type="checkbox"/>	<input checked="" type="checkbox"/>	93251
Yes	<input type="checkbox"/>	<input type="checkbox"/>	<input type="checkbox"/>	<input type="checkbox"/>	<input checked="" type="checkbox"/>	88850
Yes	<input checked="" type="checkbox"/>	<input type="checkbox"/>	<input type="checkbox"/>	<input type="checkbox"/>	<input checked="" type="checkbox"/>	98000
Yes	<input checked="" type="checkbox"/>	<input checked="" type="checkbox"/>	<input type="checkbox"/>	<input checked="" type="checkbox"/>	<input checked="" type="checkbox"/>	100000
No	<input type="checkbox"/>	<input type="checkbox"/>	<input type="checkbox"/>	<input type="checkbox"/>	<input type="checkbox"/>	
<b>66.7 %</b>	<b>58.3 %</b>	<b>37.5 %</b>	<b>18.8 %</b>	<b>20.8 %</b>	<b>64.6 %</b>	<b>average 83647</b>

Figure 2. A fragment of database report on the percentage of growers that satisfy certain production requirements stated by sugar plants (screenshot)

The subject of comparison was the most common mistakes in sugar beet growing process. There were no significant differences in the scale of mistakes made by growers in 2002 and 2005. The 2005 survey revealed that number of growers that declared documenting the process decreased by 14.5%, and the number of those keeping cost records sunk by 19.1% in comparison to the year 2002. This is quite surprising, considering the current market conditions (sinking reference prices) – a careful analysis of growing methods and costs could be a basis for searching for economies or improving efficiency. Also the number of growers growing intercroops reduced from 48.3% in 2002 to 37.5% in 2005. This is considered most disadvantageous, as using green manure proved to be cost effective. The final plant density per

hectare was in 2005 known to 64.6% growers, which is by 6.5% more than in 2002; the density was though too low (average 83 647 roots per hectare). Increase of plant density (90 – 110 thousand roots per hectare) is recommended to reduce weed growth and improve the quality of roots (raises sugar content, reduces melassigenic components content).

The data collected by 2003 survey were stored in paper enquiry forms, and information was extracted by laborious browsing of the material. The 2005 survey data was immediately fed into the database, and manipulating them to extract information was easier beyond compare.

By means of Microsoft Access it is possible to present data in customizable way. For instance, plantations can be divided into size groups, and for each group an average beet yield and average sugar content can be calculated (Figure 3). Easy data manipulation and clear reporting allow the user to infer on relationship between plantation size and raw material yield or quality.

<b>Plantation size vs yield per hectare and sugar content</b>		
<b>Plantation size</b>	<b>Beet yield (t/ha)</b>	<b>Sugar content (%)</b>
<b>&gt; 5ha</b>	<b>48.99</b>	<b>19.31</b>
<b>0-5ha</b>	<b>42.12</b>	<b>19.26</b>

Figure 3. Database report showing yield per hectare and sugar content according to plantation size (screenshot)

## Conclusions

- Collecting large amounts of experimental data on growing methods and their results and storing them in a database that facilitates easy extraction of information allows preserving, applying and sharing knowledge obtained by experience and helps to verify suitability of methods used in agriculture;
- MS Access, as a widely available tool for creating flexible databases can be used to facilitate sugar beet production planning and process analyses;
- It is possible to make complex analyses and calculations based on large number of data and any set of criteria using standard MS Access procedures, for instance to establish yield per hectare according to plantation size or according to fertilizer type and dose;
- Using the database reduces calculation errors;
- Creating a user interface – an enquiry form – simplifies inputting the data and extracting needed information;
- Clear database reports showing ordered and summarised data facilitate inference process; this can be an important support for growers and sugar

plant's supplies in the process of improving efficiency of the sugar production system.

## References

- Bzowska-Bakalarz M., Bieganowski A., Gil K. 2005. The equipment as an element of the sugar beet production system. *Gazeta Cukrownicza* 12, pp.334-337 (In Polish).
- Bzowska-Bakalarz M., Bieganowski A., Bartnik G., Banach M. 2003. Assessment of sugar beet production process in Lublin region. Analysis of production technology. *Inżynieria Rolnicza* 13, pp.111-117 (In Polish).
- Council Regulation (EC) No 318/2006 of 20 February 2006 on the common organisation of the markets in the sugar sector.
- Council Regulation (EC) No 319/2006 of 20 February 2006 amending Regulation (EC) No 1782/2003 establishing common rules for direct support schemes under the common agricultural policy and establishing certain support schemes for farmers.
- Commission Regulation (EC) No 290/2007 of 16 March 2007 establishing, for the 2007/2008 marketing year, the percentage provided for in Article 19 of Regulation (EC) No 318/2006.
- Cukier i skrobia. 2007. Wydawnictwo Bartens, 2006.
- Przybył J., Błażczak P., Urban A. 2002. A computer for evaluation of a sugar beet plantation and a crop quality. *Inżynieria Rolnicza* 2(35), pp. 249 – 258 (In Polish).
- Przybył J., Sęk T., Kowalik I., Dach J. 2004. The sugar beet integrated tillage. *Journal of Research and Application In Agricultural Engineering*, vol. 49(1), pp. 78 -83 (In Polish).
- Šařec P., Šařec O. 2007. Software support of field trials focused on sugar beet. *Proceedings of the Conference X Ogólnopolska konferencja naukowa. Zastosowanie technologii informatycznych w rolnictwie. Kazimierz Dolny*, pp.57.
- Szeptycki A. 2005. Appraisal of Effectiveness of Modernization of Vegetable Production Technology as Exemplified by Sugar Beet Crops. *Inżynieria Rolnicza* 7, p.323 -329 (In Polish).
- Zalewski A., Pietruch Cz. 2006. IT tools in plant production (In print).

## **INPUT BALANCING IN SUSTAINABLE AGRICULTURE USING COMPUTER TECHNOLOGIES**

*Michał Cupiał, Sylwester Tabor*

*Agricultural University in Krakow, Department of Agricultural Engineering and Informatics,  
Kraków, POLAND*

*e-mail: Michał.Cupiał@ar.krakow.pl  
tabor@ar.krakow.pl*

**Keywords:** sustainable agriculture, computer program, application, information

### **Introduction**

It is emphasized in many scientific papers that the possibilities of sustainable development of farms are determined by natural, economic and organizational conditions. It should be reminded, however, that sustainable agriculture is above all a complex management system which makes use of technical and biological progress harmoniously in an economically and ecologically justified way. It is the only way to obtain steady agricultural income in a longer period of time without any threat to the natural environment.

Past research shows that the crop amount in sustainable agriculture is only by 3-7% smaller than in the conventional system (Krasowicz, Kukuła 1998). Still, these are mostly results of tests conducted by research centers. The basic limitation in introducing the sustainable agriculture system is the fact that it demands a relatively high level of professional knowledge from the agricultural producers. The acquaintance with natural conditions allows to choose the proper intensity of organization of plant and animal production, particularly the choice of crop rotation, sowing structure and the number of particular species of animals. The familiarity with economic conditions allows efficient input substitution and minimizing the costs of production. In order to rise to such challenges, it is necessary to introduce an IT system enabling at least balancing the basic inputs.

On the Polish IT market, few programs can be found which help with balancing the inputs in sustainable agriculture. We can name two: NawSald created by the Institute of Soil Science and Plant Cultivation (IUNG) in Puławy [IUNG offer 2007] and Agronom 2007 offered by the AgroPower Company [AgroPower offer 2007]. Both applications are commercial and rather complicated to handle and therefore not likely to be widely applied in Polish farms very soon. Most of the farmers owing small and medium farms as well as those lacking the knowledge needed to handle such an application won't buy it. In such cases the complexity of the possibilities makes the IT harder to introduce.



## The method and results

Sustainable agriculture demands much more knowledge than the traditional system. For the right results, certain IT applications must be introduced to enable the right input balancing and the usage of appropriate technologies. An attempt at creating such a program has been undertaken at the Department of Agricultural Engineering and Informatics on the Academy of Agriculture in Cracow. The project is based on an application supporting mineral fertilizing Nawozy-2 (Cupiał 2005, 2006). The existing program is expanded with new options as well as additional databases.

For its right functioning, the program supporting input balancing needs a lot of information. Most important are presented on fig. 1.

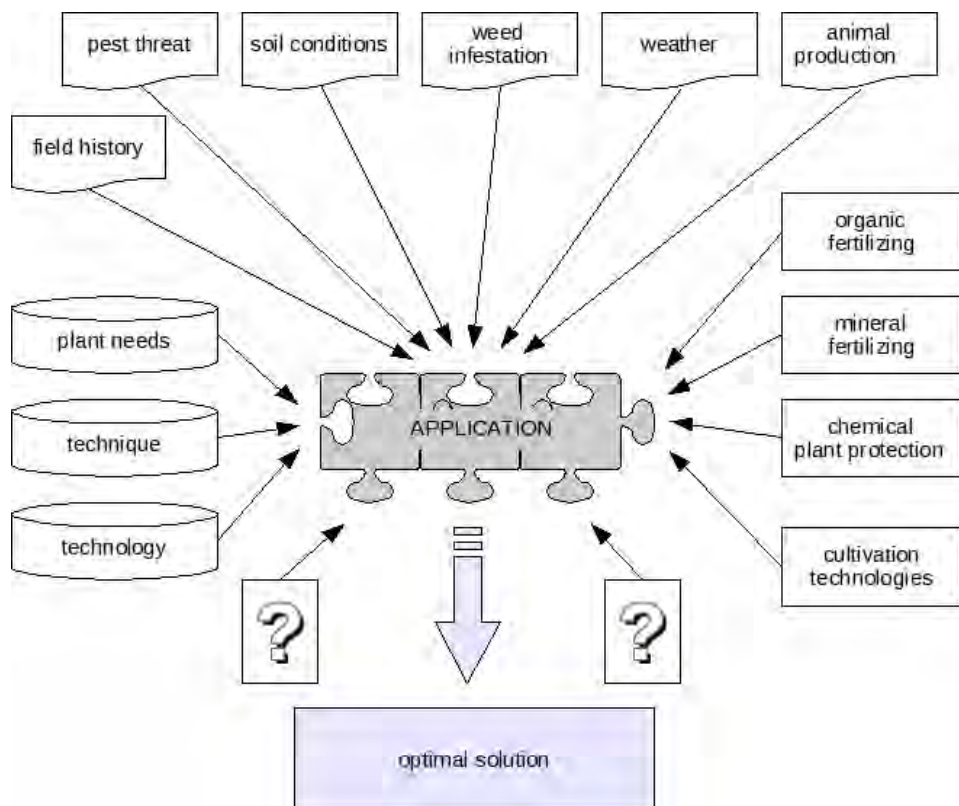

Figure 1. Incoming data for an application supporting input balancing in sustainable agriculture.

The required information was divided into 3 groups:

- connected with direct inputs (right side of the diagram)
- current information depending on the farming conditions, concerning the particular farm etc. (upper part of the diagram)
- data that can be gathered in the program database.

Apart from that the application should also consider factors that are hard to predict while writing the program – such as unexpected random events.

A different division of the incoming data is based on how often and from what sources it will be delivered. From this point of view the data can be divided to the following groups:

1. Data gathered in the program database – it increases the workload involved in creating the program, but it's the easiest to access for the user – if the build-in database is large, it makes the first contact with the program easier, which makes it more likely that the user will accept it.
2. Historical (concerning the farm) – such as the history of the fields, the scope of animal production – this kind of information has to be filled in by the user, so large amount of it will discourage the user from using the program.
3. Current (concerning the farm) – like the previous group, it has to be filled in by the user. However, results can be seen immediately after filling such information, so the farmers won't have to be 'forced' to fill them.
4. Outer data (periodically actualized) – such as modern technical means or current farming techniques and technologies – can be actualized in new editions of the program.
5. Outer data (current) – concerning the weather, pest threat, prices of products and means of production, should be regularly downloaded from the internet or filled in manually.

Only delivering such a wide range of data to the application enables conducting the proper calculations and, as a result, providing the farmer with a proper plan of work. In order to consider so many factors influencing the technological process, suitable counting algorithms must be designed. Therefore, the works leading to developing the application include: gathering and arranging the incoming data, creating suitable algorithms, implementing methods allowing to get information from sources outside the application and a user-friendly interface.

## **Summary**

The described IT application allows input balancing in sustainable agriculture. It contains the proper dosing of organic and mineral fertilizers with appropriate agro-technical terms considered. It also takes into consideration the technical means that are used and the right choice of their exploit parameters. Only such a complex solution provides high effectiveness of the inputs.

## References

1. Cupiał M. 2005. Program wspomagający nawożenie mineralne "Nawozy-2". Inżynieria Rolnicza 14 (74),
2. Cupiał M. 2006. Systemy wspomagania decyzji dla gospodarstw rolniczych (rozprawa habilitacyjna). Inżynieria Rolnicza 9 (84),
3. Krasowicz S., Kukuła S. 1998. Porównanie trzech systemów rolniczych w gospodarstwach Polski. Zeszyty Nauk. AR Kraków, 55, pp. 231-239
4. Woś A., Zegar J. S. 2002. Rolnictwo społecznie zrównoważone. IERiGŻ, Warszawa.
5. Oferta IUNG [online]. 2007. [from 15-09-2007 Internet: [http://www.iung.pulawy.pl/\\_Oferty.html](http://www.iung.pulawy.pl/_Oferty.html)
6. Oferta Agropower [online]. 2007. [from 15-09-2007]. Internet: <http://www.agropower.pl/index.php?m=2>

## **CHANGES IN TECHNICAL EQUIPMENT AND EUROPEAN UNION GRANTS IN CHOSEN FARMS OF LUBLIN PROVINCE**

*Jarosław Figurski, Edmund Lorencowicz*  
*Agricultural University in Lublin, Department of Machinery Exploitation and Management*  
*in Agricultural Engineering, Lublin, POLAND*  
*e-mail: edmund.lorencowicz@ar.lublin.pl*

**Keywords:** machinery equipment, EU grants, investments

### **Introduction**

From the beginning of the 90's Poland has been using funds from the EU budget. The funds, used before and after Poland joined the EU structures, aim mainly to raise the Polish agriculture to the level of the EU agriculture. The new member countries traditionally have problems with accessing the EU funds. The positive Polish balance with EU has been reached mainly thanks to farmers. The importance of the agriculture sector is illustrated by the fact that it takes 45% of EU budget.

### **Aim, range and methodology of investigations**

The aim of the study was to assess changes in technical assets as well as the use of European Union grants. Questionnaire surveys which were carried out in selected farms in 2001 and 2006 included, among others things, the analysis of the purchase of machines, the modernization of the equipment and infrastructure. This period of examinations gave the possibility to determine changes in the technical equipment after joining the EU structures.

The survey was done by people employed by Agricultural Extension Centers from the areas where the farms were located. The investigators knew the scope of research and also the farmers who responded to the poll. There were 118 correctly filled up questionnaire forms received from the farms.

In order to determine the relation between union funds and investments in machines the questionnaire was compared in pairs; for the same farms in 2001 and 2006.

### **Characteristics of examined holdings**

The majority of farms' owners were 40 to 49 years old. There were only 8 owners above 60 years old. Comparing the results of polls in 2001 and 2006, there was a slightly increment in the lowest age range; it increased from 9.7 % in 2001 to 10% in 2006 (Table 1).

Table 1. Farmers age structure in investigated farms

Age	Number of farmers	Percentage [%]
20 – 29 years	12	10,1
30 – 39 years	24	20,4
40 – 49 years	39	33,1
50 – 59 years	35	29,6
60 years and more	8	6,8
Total	118	100

The average arable area of farm was 13.35 ha (median 9.60), the biggest was about 145 ha, and the smallest only 2.1 ha.

The high value of the coefficient of variation showed the big area difference. However, it was also highly influenced by two big farms (over 100 hectares) which differed greatly from the average of the population.

### The technical equipment and its changes

The investigated farms had sufficient number of tractors (Table 2)

Table 2. Number of tractors

Detailed list	Unit	Value in the year	
		2001	2006
Number of tractors	Units	144	139
Number per 100 ha of the farmlands	units/100 ha	11,2	8,8
Number of tractors per 100 farms	units/100 farms	122,0	117,7
Medium age	Years	18,1	21,2
- including: up to 5 years	%	1,4	4,3
over 20 years	%	31,9	53,9

There were 139 agricultural tractors in farms under analysis in 2006, from which a straight majority were tractors with long life cycle; almost 54% of them were already more than 20 years old (Table 2). There was a little change of machines but the medium age of the tractor was over 20 years. It rose in 2006 by 3.1 year compared with 2001. Number of tractors younger than five year rose by the 2.9% and it amounted to the 4.3% which indicated new purchases.

There was a disadvantageous change in the age structure of the combine harvesters (Table 3). There were over 32% (median 18.00) over 20 year old machines in 2001. In 2006 - 66.7% of used combine harvesters exceeded this age limit (median 25.00). There were no harvesters younger than five years. That means that in the period 2001-06 farmers bought only second-hand combine harvesters.

Table 3. Number of combine harvesters

Detailed list	Unit	Value in the year	
		2001	2006
Number of combine harvesters	units	28	30
Number per 100 ha of the farmlands	units/100 ha	1,4	1,9
Number of combine harvesters per 100 farms	units/100 farms	23,7	25,4
Medium age	years	18,5	24,8
- including: up to 5 years	%	0	0
over 20 years	%	32,1	66,7

The most beneficial situation appeared in the age structure of spraying machines. The biggest number of spraying machines was below 10 years old. However, the share of spraying machines over 20 years increased twice between 2006 and 2001 and was over 10.4% of total number of the machines (Table 4).

Table 4. Number of sprayers

Detailed list	Unit	Value in the year	
		2001	2006
Number of sprayers	units	87	86
Number per 100 ha of the farmlands	units/100 ha	4,4	5,5
Number of sprayers per 100 households	units/100 households	73,7	72,8
Medium age	years	10,8	11,9
- including: up to 5 years	%	18,3	8,1
over 20 years	%	4,6	10,4

There were 64 spreaders of fertilizers used in the examined population of households in 2006. One fourth of them were younger than 10 years. Machines over twenty years old constituted 15.6% of this group. In comparison to the previous investigation there were 2.9% more of the youngest spreaders. Medium age, in 2001 - 13.9 years, rose after the period of 5 years only by 0.2 year which indicated the change of the equipment to new or used but younger (Table 5).

Table 5. Number of spreaders of fertilizers

Detailed list	Unit	Value in the year	
		2001	2006
Number of spreaders of fertilizers	units	92	64
Number per 100 ha of the farmlands	units/100 ha	4,7	4,1
Number of spreaders of fertilizers per 100 farms	units/100 farms	77,9	54,2
Medium age	years	13,9	14,1
- including: up to 5 years	%	6,5	9,4
over 20 years	%	6,5	15,6

Examinations enabled also the analysis of other groups of agricultural machines. However, only the four basic groups of machines were chosen for the study since the changes in the remaining machines did not influence the result of analysis in any essential way.

### European Union subsidies versus purchase of the technical equipment

Accession to the EU structures opened new possibilities of receiving funds by farmers. In the analyzed group of farms there were 26 farms which co-financed their activity with the help of the Union funds. Seven forms of using the received funds were determined (Table 6).

Table 6. Forms of using funds obtained from the EU

Forms of using the founds	Number of farms	Percentage [%]
Purchase of new machines	10	38,5
Purchase of used machines	6	23,1
Purchase of both new and used machines	6	23,1
Purchase of new machines and the modernization of buildings	1	3,8
Purchase of used machines and the modernization of buildings	0	0
Modernization of buildings	1	3,8
No information	2	7,7
Total	26	100

Money acquired from Union's programs was most often allocated to the purchase of new machines.

Half of beneficiaries were owners of farms of the arable area from 10 up to 20 ha; interestingly all of the farms of the arable area over 40 hectare obtained funds from EU programs (Fig. 1).

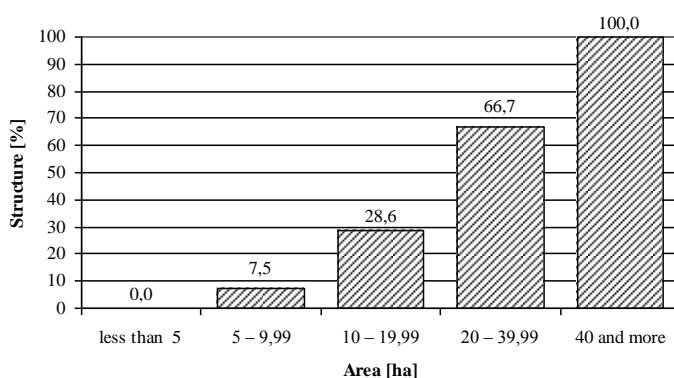

Figure 1. EU subsidies versus the farms area

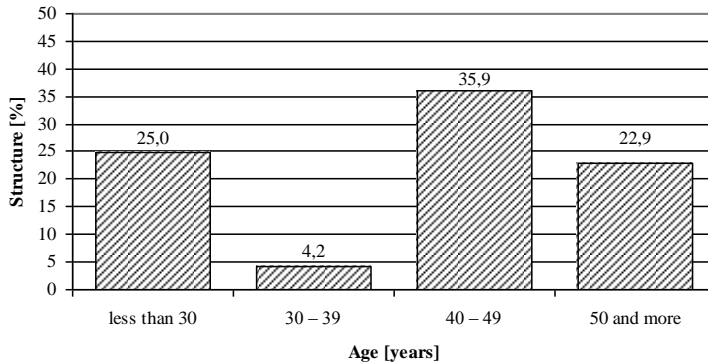

Figure 2. EU subsidies versus the age of farmers

The age of farmers was a factor which could influence the participation in relief programs. Over 50% of recipients of union funds constituted the group of 40 – 50 years old (Fig.2). It was in accordance with the general structure of the owners' age (Fig.1).

### Summary

The accurate determination of changes in farms technical equipment requires further research. Without doubt funds acquired from the EU influenced the condition of Polish agriculture. Direct payment, co-financing investment and programs directed to young farmers were indeed a good method to improve the situation in the agricultural sector. After joining the EU structures farmers were given new possibilities of raising funds for the development of their farms.

According to the findings from the above research done in 2001 and 2006 every fifth from 118 farms benefited in some way from EU programs. Beneficiaries utilized the money received from Union programs mainly to purchase new (38.5%) and used (25%) machines.



## **CONTRIBUTION OF THE REGIONAL SIGNALIZATION AND WARNING SYSTEMS FOR PESTS AND DISEASES INFESTATION TO SUSTAINABLE AGRICULTURAL**

*Maciej Gałęzewski*

*Plant Protection Institute Department of Forecasting and Registration Pest and Diseases,  
Poznań, POLAND*

*e-mail: M.Galezewski@ior.poznan.pl*

**Keyword:** regional signalization, pest/disease occurrence, monitoring

### **Introduction**

Correctly providing monitoring and signalization of agrophages' occurrence on the agricultural plants is one of the most crucial elements of effective plant protection. Providing correct signalization and advisory service, one has to remember that in terms of first appearance or in developmental stages of pests/diseases significant differences are observed. These differences sometimes reach two weeks between different regions of the country, one week within region and few days within the county. Even at the same place (one village – different plantations) the differences of pests or diseases appearance can be observed.

The main purpose of regional signalization is determining the optimal time of chemical control on the specific plantation which gives opportunity to reduce the costs, number of chemical treatments and subsequently risk of environmental pollution.

### **Methods**

During vegetation season in chosen places, on concrete fields, observation of diseases and pests are provided. The results are published on the Institutes' website ([www.ior.poznan.pl](http://www.ior.poznan.pl)) under "Sygnalizacja Agrofagów" (Pests/diseases signalization).

In case of agrophages which must be controlled in specific development stage (e.g. *Oulema* spp.) the need of chemical treatment is signaling. For the other pests and diseases monitoring till threshold – (the moment of chemical treatment) is provided or as long as agrophag can be danger for crop.

Some interesting information about other pests/diseases are published on "Aktualności" ("News") section.

On the website some information about aphids migration are also shown. Studies are provided by using two Johnson's aspirators located at south and west part of Poland.

## Results

Observations are provided since 2005. In 2007 fields are located in four regions:

- Wielkopolska region (four places – Winna Góra, Słupia Wielka, Kościelna Wieś, Baborówko) – west part of Poland,
- Śląsk region (Sośnicowice) – south Poland,
- Kujawsko-Pomorskie region (Więclawice) – north Poland,
- Mazowsze region (Chylce) – central part of Poland.

Observations were concentrated on:

- cereals: powdery mildew, rust, cereal leaf beetles, saddle gall midges and aphids,
- potatoes: late blight and colorado leaf beetle,
- sugar beet: cercospora leaf spot, aphids, cutworms and beet fly,
- winter rape: dry-rot of cabbage, dark leaf-spot of rape sclerotinia rot, rape blossom beetle, ceutorrhynchid

In the tables 1-2 some information regarding to regional signalization are shown.

Table 1. Cereal leaf beetle (*Oulema* spp.) occurrence on winter wheat in 2007 vegetation season

Date of observation	Development stage	Kościelna Wieś	Słupia Wlk.	Winna Góra	Notes
12.04.2007	First beetles	no beetles	first beetles	first beetles	
16.04.2007	beginning of eggs laying			first eggs	
19.04.2007	beginning of eggs laying		first eggs		
23.04.2007	beginning of eggs laying	first eggs			
23.04.2007	eggs laying		16 eggs/50 stalks	10 eggs/50 stalks	
27.04.2007	eggs laying			14 eggs/50 stalks	
02.05.2007	First larvae emergence	2 larvae/50 stalks			
07.05.2007	First larvae emergence	a few larvae			
14.05.2007	First larvae emergence		first larvae	first larvae	
14.05.2007	larvae emergence	a few larvae			
18.05.2007	larvae emergence		larvae emergence		
21.05.2007	massive larvae emergence			15 larvae & 4 eggs/100 stalks	
22.05.2007	larvae emergence		a few larvae		oldest larvae - 3-3,5 mm
28-31.05.2007	massive larvae emergence	a few larvae/ 100 stalks	9 larvae/100 stalks	18 larvae/100 stalks	oldest larvae reach 4 mm; no threshold; treatment not recommended

Table 2. Ceutorhynchid beetle (*Ceutorhynchus quadridens*) occurrence on winter rape in 2007 vegetation season

Date of observation	Development stage	Baborówko	Sośnicowice	Winna Góra	Notes
09.03.2007	first beetles	1 beetle / yellow trap / 4 days	a few beetles / yellow traps		
13.03.2007	first beetles			5 beetles / yellow trap / 4 days	
14.03.2007	incursion of beetles		a few beetles / yellow traps	9 beetles / yellow trap / 5 days	Winna Góra: number of beetles + warm weather = treatment recommendation
19.03.2007	first beetles	no beetles	a few beetles / yellow traps		cooler weather
30.03.2007	first beetles	no beetles			
03.04.2007	first beetles	no beetles			
10.04.2007	incursion of beetles	no beetles			cooler weather
12.04.2007	incursion of beetles	no beetles	a few beetles / yellow traps	no beetles	
26.04.2007	incursion of beetles		2 beetles / yellow trap		

## **ECONOMIC ANALYSIS OF ENERGY MANAGEMENT OPTIONS OF PLANT PRODUCTION SYSTEMS**

*Duane Griffith<sup>1</sup>, Edmund Lorencowicz<sup>2</sup>*

*<sup>1</sup>Montana State University, Department of Economics and Agricultural Economics,  
Bozeman, USA*

*e-mail: griffith@montana.edu*

*<sup>2</sup>Agricultural University in Lublin, Department of Machinery Exploitation and Management  
in Agricultural Engineering, Lublin, POLAND*

*e-mail: edmund.lorencowicz@ar.lublin.pl*

**Key words:** energy in agriculture, economic analysis, management of energy, energy use by tillage system, energy use by crop mix

### **Introduction**

Energy price continues to remain high for agriculture producers with spot crude oil prices approaching \$80 per barrel at the time of this writing (fig.1). On-farm diesel fuel price is currently about \$2.25 per gallon. Diesel used on the farm, commonly referred to as off-road diesel, does not include the per gallon tax charged by the federal and state governments as a road use tax.

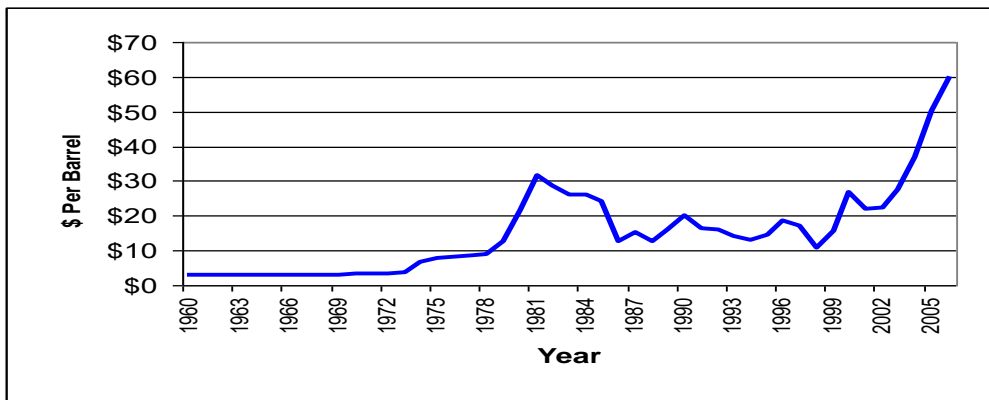

Figure 1. U.S. Yearly Crude Oil Prices, Nominal Dollars

Natural gas prices have declined slightly from their highs of about \$15 per thousand cubic feet to about \$11.50 per thousand cubic feet. Natural gas prices are a major factor in determining the price of fertilizers. Figure 2 indicates an almost perfect relationship between the price of natural gas and the price of Anhydrous Ammonia since 1995.

Energy cost management efforts by farmers are dictated by the type of energy costs increases occurring. Farmers have several options to manage fuel and fertilizer costs which include reinvestment in newer more fuel efficient

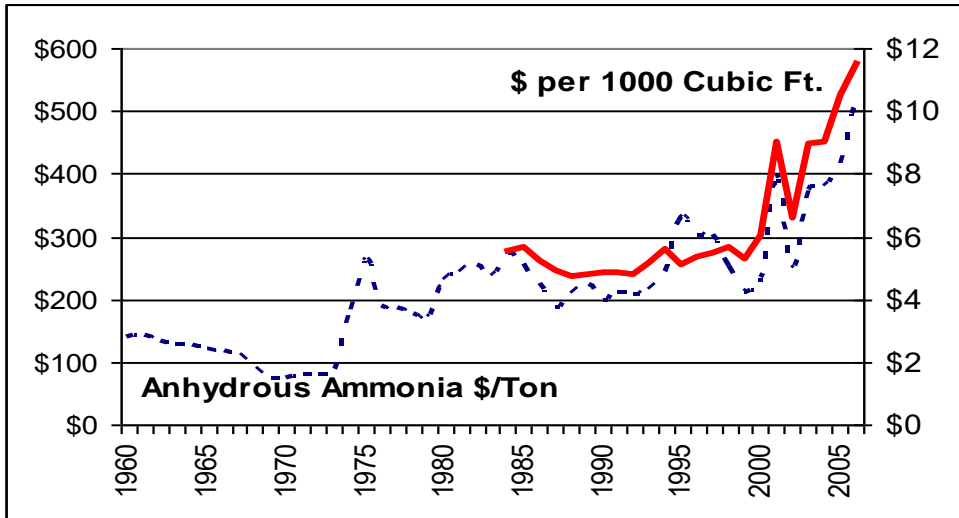

Figure 2. Cost Per Ton of Anhydrous Ammonia and Per Thousand Cubic Feet of Natural Gas, Nominal Dollars

machinery to simpler options like switching to a less tillage intensive production system and/or changing crop rotations to minimize fertilizer use. Producers must be careful that efforts to manage energy costs do not significantly reduce net income. They must manage for a wide variety of resource, production, labor and marketing constraints, all of which affect net income and the ability to move toward the future as a viable agriculture operation. Attributing a producer's management decisions to only one or two production variables, like fuel or fertilizer costs can also be misleading.

To analyze possible options for energy cost management, the authors have provided producers with spreadsheet based decision aids that allow what-if scenario analysis. These decision aids have been based on Excel and Quattro Pro, but more recently have included compiling Excel spreadsheets into Flash files that eliminate the need for a producer to own spreadsheet software. Flash files only require a web browser like Internet Explorer and a Flash file player, a free download. The objective of these spreadsheet decision aids is to provide producers with a tool to analyze the implications of management decisions based on all possible objectives for individual operations, but primarily for controlling energy cost.

### **Principles (methodology) of preparing spreadsheet**

Producers have differing levels of experience with spreadsheet decision aids, but most are familiar with spreadsheets and use them on a frequent basis. Energy management decisions that involve entire production systems are much more complex and require considerable input from producers. Farm

specific analysis requires producers to enter large amounts of data for their individual operation. This includes the physical and economic characteristics (power, width, efficiencies, value, etc.) of their entire machinery complement, their typical crop rotation, and the implement power unit match for each operation on each crop. This information allows the spreadsheet to estimate machinery ownership and operating costs for each crop enterprise. Machinery cost estimates also provide the producer with the information necessary to start making energy management decisions for their crop production system. Examples include relatively simple changes like comparing tillage systems to reduce the number of operations with tractor implement combinations to more complex analysis like evaluating the cost of reinvesting in newer more fuel efficient machinery.

Estimating machinery ownership and operating costs is not enough. Management decisions must be based on long run profitability which is determined by crop mix, expected yield, existing markets and the variability of those markets. To accurately estimate the profitability of these factors combined, machinery costs must be allocated to each enterprise. Significant changes in expected costs and revenues can occur if crop rotations and hence machinery usage is changed for any given operation. In addition to machinery ownership and operating costs estimates by crop, all of the operating inputs (seed, fertilizer, chemicals, ...) for each crop in the rotation must be entered into the spreadsheet models. Farmers know all of this information, but some are reluctant to spend this much time using a computer. The author's decision aid includes all of this input and is too lengthy to detail in this paper.

Machinery ownership costs estimated are depreciation, interest, taxes and insurance. Operating costs estimated include fuel, oil and other lubricants and repairs. These estimates are based on previously established algorithms by engineers and economists.

Formulas used to calculate the operating costs are:

Annual Operating (Variable) Cost Calculations:

$$\text{Fuel costs} = \text{Machine Power} * \text{Fuel Factor} * \text{Hours Annual Use}$$

Hours annual use is calculated by the model based on actual machine use for a given crop mix and farm size.

$$\text{Oil Costs} = 5\% \text{ of total Fuel Costs}$$

Engineering estimates for lubricant costs are 15% of total fuel costs. The percentage used in this paper is 5% based on producer feedback indicating lubricant cost estimates were high.

$$\text{Repairs} = \text{Machinery Type} * \text{Original List Price} * \text{Repair Factor}$$

Annual Ownership (Fixed) Cost Calculations:

$$\text{Taxes} = \text{Average Value} * \text{Taxable Value Rate} * \text{Local Mill Levee}$$

Mill levee is a factor used in calculating the dollar amount of taxes due on personal property, such as machinery. As tax expenses are highly variable based on the local and regional political boundaries, this calculation should be made use local conditions.

$$\text{Insurance} = \text{Average Value} * \text{Premium Rate}$$

$$\text{Interest (Opportunity) Cost} = \text{Average Value} * \text{Real Interest Rate}$$

$$\text{Depreciation} = ((\text{List Price} - \text{Salvage Value}) \div \text{Hours Useful Life}) * \text{Hrs Annual Use}$$

Depreciation is not treated in a financial framework in this model. It is based on hours of annual use and as machine use changes, annual depreciation estimates can either increase or decrease. Depreciation then, takes on the characteristics of a variable expense, but is still included in the fixed cost portions of the calculated results.

These basic equations were used to build a model in Microsoft Excel that compares the economics of all possible variables that can impact the economic considerations a producer must make. Once the model was finished, the Excel spreadsheet was compiled into a Macromedia Flash file. The person creating the Flash file can control what portion of the model an user will see. The full model can also be used by producers with access to Excel.

Figure 3 contains summary results for tillage systems and the base case scenario crop mix used for this paper. The procedures and methodology discussed above describe the information a producer must have to accurately evaluate the economics of energy management decisions within an entire production system. The discussion also indicates a level of user interaction that is greater than many producers wish to get involved with. To help producers with energy management decisions that include the variables discussed, a new approach is being explored. This approach is to develop case farm operations with typical machinery complements and crop enterprise mixes. These case farms include the ability to change crop mixes by simply changing the acres allocated to each crop. This includes introducing a new crop in the typical rotation by reducing acreage of an existing crop.

		Mechanical Till	Minimum Till	NoTill	Summary	Description	Corn/Ethanol	Biodiesel	Last Revised March 7, 2007		
\$2.25	Diesel \$/Gallon	\$2.20	Gas \$/Gallon	100%	% of Fertilizer Prices	100%	% of Chemical Prices				
<b>Double Click Box and Enter a New Number for Acres, Yields and Prices Below.</b>											
	Acres Planted	WW on Fallow	SW on Fallow	WW on Recrop	Barley on Recrop	Summer Fallow	Canola Recrop	Flax on Recrop	Lentils on Recrop	Camellina	Total Acres
	Expected Yield	200	800	0	250	1,000	0	0	0	0	2,250
	Expected Price	35	30	30	40		1200	20	16	1000	
		\$4.76	\$4.85	\$4.76	\$2.80		\$0.100	\$5.90	\$7.00	\$0.100	
<b>Total Costs for All Enterprises by Tillage System</b>											
		Mechanical Tillage	Percent of Base Case	Minimum Till System	Percent of Base Case	No Till System	Percent of Base Case				
<b>Acres in this operation</b>		<b>2,250</b>	<b>100%</b>	<b>2,250</b>	<b>100%</b>	<b>2,250</b>	<b>100%</b>				
<b>Total Income</b>		<b>\$191,878</b>	<b>100%</b>	<b>\$191,878</b>	<b>100%</b>	<b>\$191,878</b>	<b>100%</b>				
Seed and Treatments		\$5,680	100%	\$5,680	100%	\$5,680	100%				
Total Chemicals		\$18,874	100%	\$21,055	100%	\$32,123	100%				
Total Fertilizers		\$26,863	100%	\$30,613	100%	\$26,863	100%				
Crop Insurance		\$3,854	100%	\$3,854	100%	\$3,854	100%				
Other Misc Costs		\$400	100%	\$1,025	100%	\$400	100%				
Machinery Operating Cost		\$35,587	100%	\$31,126	100%	\$26,098	100%				
Interest on Operating		\$6,246	100%	\$6,324	100%	\$6,584	100%				
<b>Total Operating Cost</b>		<b>\$97,504</b>	<b>100%</b>	<b>\$99,677</b>	<b>100%</b>	<b>\$101,602</b>	<b>100%</b>				
Machinery Ownership Cost		\$34,628	100%	\$33,104	100%	\$30,741	100%				
Total Ownership Cost		\$94,291	100%	\$92,767	100%	\$90,404	100%				
<b>Total Operating and Ownership Cost</b>		<b>\$191,795</b>	<b>100%</b>	<b>\$192,444</b>	<b>100%</b>	<b>\$192,006</b>	<b>100%</b>				
<b>Returns over operating cost</b>		<b>\$94,373</b>	<b>100%</b>	<b>\$92,200</b>	<b>100%</b>	<b>\$90,276</b>	<b>100%</b>				
Returns over total cost		\$83	100%	-\$566	100%	-\$128	100%				
Total Gallons of Fuel used for this crop mix		11,407	100%	10,491	100%	9,917	100%				
Total Fuel and Lubricant costs for this crop mix		\$26,936	100%	\$24,768	100%	\$23,383	100%				
Hours of Machinery Time Required		458	100%	399	100%	355	100%				
Machinery Investment costs by tillage system		\$459,500	100%	\$459,500	100%	\$459,500	100%				

Figure 3. Results of a typical case farm in Southern Montana and Eastern Wyoming

## Recapitulation

Producers use the Excel versions of the spreadsheets described in this paper to prepare detailed enterprise cost estimates for their operations. These cost estimates are used to establish crop mixes, evaluate changes in machinery complements, and examine potential capital labor tradeoffs for their operations. Compiling the spreadsheets into Flash files using typical case farms actually reduces the ability of an individual user to analyze a specific set of circumstances. However, compiling these spreadsheets into Flash files has substantially increased the use of these spreadsheets. The typical case farm operations built into the spreadsheets allow producers to get an initial evaluation of many different management decisions they have available, even when their operation may not exactly match the typical case farm. The Flash file format has also extended the use of the spreadsheets to USDA agencies which are also interested in the economic considerations faced by producers and the potential energy savings that can result for tillage system, crop mix combinations.

A complete rewrite of the model, converting it to a metric system with applicability to Europe, is planned in the near future. If possible, the model will be made database driven during this rewrite. This will be similar to the database driven Quattro Pro template that we worked on years ago. Users will then be able to select their own machinery complement and crop mix rather than using a single case farm approach.



## **THE EFFECT OF UPDATING SELECTED OPERATIONAL- ECONOMIC INDICES ON THE OPERATION COSTS OF NEW-GENERATION FARM TRACTORS**

*Zenon Grześ*

*August Cieszkowski Agricultural University in Poznań, Institute of Agricultural Engineering,  
Poznań, POLAND*

*e-mail: zgrzes@au.poznan.pl*

**Keywords:** operational-economic indices, operation costs, current values, agricultural machines and tractors

### **Introduction**

The application of novel construction solutions as well as the increasing introduction of electronics in the design of modern agricultural machines cause that they are becoming more and more efficient and cheaper in the course of their operation. Therefore, operational-economic indices determined many years ago on the basis of the operational experiments carried out at that time and which are still employed to calculate operation costs of agricultural machines have now gone out of date (System of Agricultural Machines 1988). Calculations of the operation costs of new generation agricultural machines which were obtained using the old values of these indices are burdened with errors.

The process of marketing of Polish agriculture which took place after 1989 led to considerable changes in the structure of technical equipment of Polish farms. That is why investigations have been undertaken at the Institute of Agriculture Engineering of the Agricultural University in Poznań with the aim to determine current values of the discussed indices (Grześ 2004, 2005; Grześ and Kowalik 2005).

The main objective of the prepared elaboration is to assess the impact of the updating of the operational-economic indices on the operation costs of new generation farming machines currently used in conditions of Polish agriculture.

### **Method**

The investigations were carried out in the year 2006 employing new generation agricultural tractors of John Deere (JD) Company of 66 and 217 kW power rating. The operation costs calculations of the experimental tractors were conducted in accordance with the principles of machine operational calculations in conditions of domestic farming (Muzalewski 2006; Karwowski 1998; Pawlak 1989). The current values of the following operational-economic indices were taken into consideration during the

performed calculations: index of repair costs, predicted period of utilisation, standard operation and annual operation. In the course of the prepared elaboration, mean values of operation costs were calculated for the individual horse rating intervals of the examined tractors (Bobrowski 1986).

The obtained results were compared with the operation costs of tractors which were obtained according to the actual calculation method (IBMER method). In addition, the author calculated operation costs of the examined tractors employing the FAT method applied to calculate operational costs of agricultural machines and equipment in Switzerland (Ammann 2004).

## Results

Table 1. Unit operation costs of John Deere farm tractors for different calculation methods

No	Calculation method of operation costs	Unit operation costs (PLN/h)				
		Rating power of tractors (kW)				
		66-92	110-125	147-165	183-198	217
1.	Method of costs update	66.60	83.97	131.42	144.56	166.00
2.	IBMER method	68.13	88.05	135.59	158.65	180.71
3.	FAT method	75.93	95.59	147.44	172.19	196.48

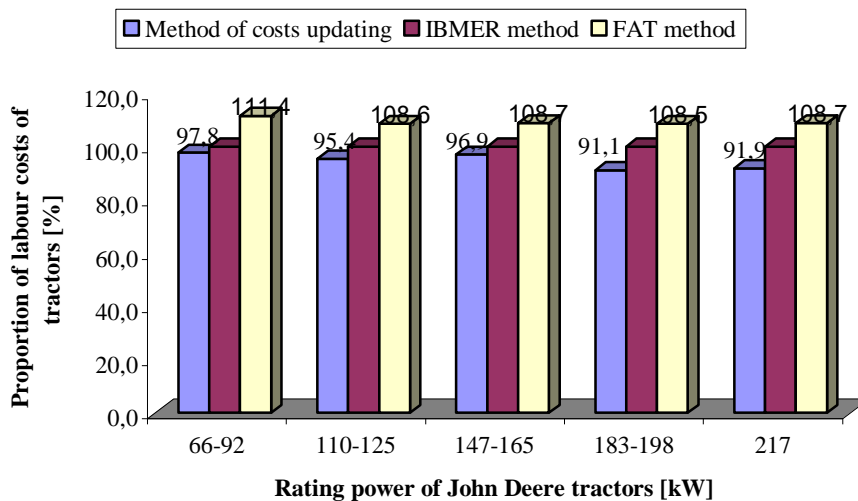

Figure 1. Percentage proportion of operation costs of the examined agricultural tractors in relation to the basic method (IBMER method = 100%)

## **Discussion of results**

Regardless of the horse rating of the examined tractors, the lowest operation costs were obtained when they were calculated on the basis of current values of the operational-economic indices (Tab. 1). These costs are by about 1.53 to 14.71 PLN/h lower in comparison with those obtained using the IBMER method. The determined difference of unit operation costs of the examined tractors generate a decrease of the user's own annual operational costs ranging from 1689 to 16181 PLN (the annual utilisation of the tractors under investigations amounted to 1100 h).

In order to make the obtained results independent from the unstable monetary dimension, it was assumed that the costs obtained with the aid of the IBMER method equalled 100. Next, the author calculated the percentage share of the costs obtained with the remaining methods in relation to the base method.

From the point of view of the percentage approach, the greatest drop of costs occurred when they were calculated by the method using the current values of individual indices and this decline ranged from 2.2 to 8.9% in relation to the IBMER method (Fig. 1). On the other hand, the greatest operation costs of the examined tractors were obtained when the FAT method was employed – the increase of operation costs ranged from 8.5 to 11.4%. However, this method assumes a relatively short period of life of agricultural tractors, namely 10 years (Ammann 2004). After this period, a significant decrease of unit operation costs will take place because amortization costs of tractor will no longer be incurred. On the other hand, in the case of the IBMER method, this period is two times longer and amounts to 20 years (Muzalewski 2006; Karwowski 1998).

## **Conclusions**

The following conclusions were drawn on the basis of the obtained research results and performed calculations:

1. The application of current values of operational-economic indices was found to have a favourable effect on the calculation of operation costs of new generation agricultural tractors.
2. The applied update of operation costs of the examined tractors reduced these costs by 2.2 to 8.9% in comparison with the calculation method employed so far (Fig. 1). Reduced tractor operation costs make it possible to cheapen machine services and agricultural production.

3. The employed FAT method is characterised by a relatively short period of working life of tractors and other farm machines. After this period, the machine is amortized which allows a quick replacement of the machine stock in agriculture. In addition, a significant reduction of fixed costs of the currently utilised machines takes place.
4. There is a justified and urgent need to undertake operational investigations with the aim of determining current values of operational-economic indices of other agricultural machines and equipment. This refers, in particular, to new grain, beet and forage harvesters as well as various cultivation aggregates, sprayers, power loader etc.

### **Bibliography**

- Ammann H. 2004. FAT – Berichte. Maschinenkosten 2005. Nr. 621.
- Bobrowski D. 1986. Probabilistyka w zastosowaniach technicznych. Wyd. WNT Warszawa.
- Grześ Z. 2004. Ekonomiczne aspekty obsługi technicznej maszyn rolniczych nowej generacji warunkach polskiego rolnictwa. PNR 1/307, pp. 141-147
- Grześ Z. 2005. Metoda aktualizacji wskaźnika kosztów napraw maszyn rolniczych nowej generacji. Problemy Inżynierii Rolniczej, nr 3, pp. 39-46.
- Grześ Z., Kowalik I. 2005. Badania rocznego wykorzystania maszyn rolniczych. Inżynieria Rolnicza, 3 (63), pp. 189-195.
- Karwowski T. 1998. Podstawy zespołowego użytkowania maszyn. Wyd. IBMER, Warszawa.
- Kowalik I., Grześ Z. 2006. Wpływ wykorzystania maszyn rolniczych na koszty mechanizacji w gospodarstwach rolniczych o różnej powierzchni. Inżynieria Rolnicza, 13 (88), pp. 201-208.
- Muzalewski A. 2006. Koszty eksploatacji maszyn rolniczych. IBMER, Warszawa. Nr 21.
- Pawlak J. 1989. Organizacyjne i ekonomiczne aspekty produkcji roślinnej w indywidualnych gospodarstwach rolniczych. PWRiL, Warszawa.
- System Maszyn Rolniczych 1988. Wskaźniki eksploatacyjno-ekonomiczne – część 14. IBMER, Warszawa.

## **COMPARATIVE STUDY OF THE PRECISION OF SIX GPS GUIDING SYSTEMS IN AGRICULTURE**

*Bruno Huyghebaert, Gaëtan Dubois, Pascal Bienfait*  
*Agricultural Research Centre (CRA-W), Agricultural Engineering Department, Gembloux,*  
*BELGIUM*  
*e-mail: genie-rural@cra.wallonie.be*

**Keywords:** *Guiding systems, GPS, precision, overlapping*

### **Summary**

Positioning system by GPS takes a great importance in our daily life. In Agriculture also several applications have been developed and meet an increasing success. For the moment, the current and functioning applications are land surveying, parcel's mapping and simple or auto-guiding.

This study aims to compare the precision of six GPS guiding systems currently marketed. These systems help the driver to maintain the working width between the routes. They should facilitate the marking out of the field and reduce the overlapping. This way, GPS guiding systems should have a positive impact on the rationalisation of the inputs application (fertilizers and pesticides) and on the environment.

The systems were tested in the field in real conditions and under the same circumstances. The two modes of functioning (straight and curved line) have been tested. A protocol has been developed and more than 4500 measurements have been realised.

In the same time, measurements have been led to determine the overlapping during cereals sowing without the help of a guiding system. The objective was to evaluate the added-value of the GPS guiding systems.

In conclusion, most of the studied systems work out correctly and answer, on average, to the precision mentioned by the manufacturers whatever the working conditions. However, the systems vary significantly from each other regarding the variability and the repeatability of their positioning. The study and the analysis of the function mode "curved line" have caused some problems. A specific protocol should be developed in the future.

### **1. Introduction**

GPS (Global Positioning System) use with the differential correction systems (dGPS) Egnos allows us to reach a precision within 30 cm.

This study aims to determine and compare the precision of six GPS guiding systems in Agriculture : Centerline 220 (LH-AGRO-TEEJET), Cultiva ATC (AUTOFARM), Isaguide (ISAGRI), John Deere GS 2600 (JOHN DEERE), Outback S (AGROCOM) and Sat 3G (GENITRONIC). Only the simple

guiding functions of systems have been studied. For this, the system give information to the driver who manually corrects the trajectory of the tractor.

## 2. Materials and methods

So as to not disturb the signal, the trials have been realised on an open site without buildings and trees around. Six parallel strips of sand have been installed on the field. They had a length of 80 m and were spaced at 20 m. The strips were perpendicular to the reference line AB.

First the tractor covers the reference line AB (straight or curve) and the guiding system installed on it registers the trajectory. Then several passages parallel to the AB line (straight or curve) have been realised taking into account the information given by the guiding system.

The **distance** between each route has been measured using the tracks let by the tractor's wheels on the sand strips. Each junction "sand strip x tractor's track" corresponds to one measurement.

At the end, 72 complete trials have been realised: 6 systems, 2 modes of functioning (straight and curve), 2 widths and 3 repetitions. In total, 2376 spaces between passages have been measured for the 6 systems.

The antennas of the guiding systems were placed on the tractor's bonnet above the front axle. The forward speed was between 6 and 7 km/h for the whole trial. Egnos was the dGPS correction system used for the whole test.

## 3. Results and analysis

### 3.1. *Overlapping during cereals sowing*

First, in order to evaluate the added value of a guiding system, measurements have been done in fields of wheat and barley. These fields have been sowed without GPS guiding system. One showed an overlapping ranging from **2 to 8 %**. This overlapping will have certainly an impact on the next works like fertilization and pesticides applications.

### 3.2. **Straight line**

Spaces between routes have undergone a statistical analysis and the descriptive parameters have been calculated (Table 1). The frequency distribution of the spaces between the routes of the tractor has been also calculated.

One observes that all systems generate, on average, spaces between routes higher than the expected working width (8 or 20 m), except for Genitronic. This one generates an overlapping, while the others produce gap.

For **8 meters** working width, all systems answer, on average, to the precision of  $\pm 20$  cm. Cultiva and Isaguide present the best performances with a deviation of only 1 cm. With an average deviation of 15 cm, Genitronic will produce an average overlapping of  $\pm 2\%$ .

Table 1. Performances ( $\bar{x}$ ,  $s$ , Min. and Max. in m) of the 6 GPS guiding systems, straight line, for 8 and 20 m working widths

Systems	Working width : 8 m				Working width : 20 m			
	Average $\bar{x}$	Standard deviation ( $s$ )	Min.	Max.	Average $\bar{x}$	Standard deviation ( $s$ )	Min.	Max.
Centerline	7.98	0.19	7.40	8.61	20.12	0.40	19.18	21.00
Cultiva	8.01	0.12	7.72	8.47	20.03	0.22	19.25	20.82
Isaguide	7.99	0.28	6.49	9.65	20.01	0.28	18.93	21.52
John Deere	8.02	0.16	7.67	8.49	20.00	0.13	19.64	20.25
Outback	8.07	0.35	6.75	9.40	20.18	0.20	19.70	20.65
Genitronic	7.85	1.24	4.96	12.00	19.55	1.11	13.86	22.53

The systems make the difference for the standard deviation. Cultiva presents a lower variability ( $s = 12$  cm) than Isaguide ( $s = 28$  cm). Although those both systems have the same average precision, the widths generated by Cultiva will be generally closer to the expected working width. Genitronic generates a very high variability ( $s = 124$  cm).

For **20 meters** working width, John Deere, Isaguide and Cultiva present a good average precision. Genitronic confirms its imprecision which corresponds always to an overlapping of  $\pm 2\%$ .

The frequency distribution is another tool which allows us to characterise the good functioning of the systems. Ideally, the frequency distribution should present the shape of a Gaussian curve: highest frequency for the average width which should be equal to the expected working width. Figures 1 et 2 show two extreme frequency distribution: Genitronic and John Deere for the 8 m working width.

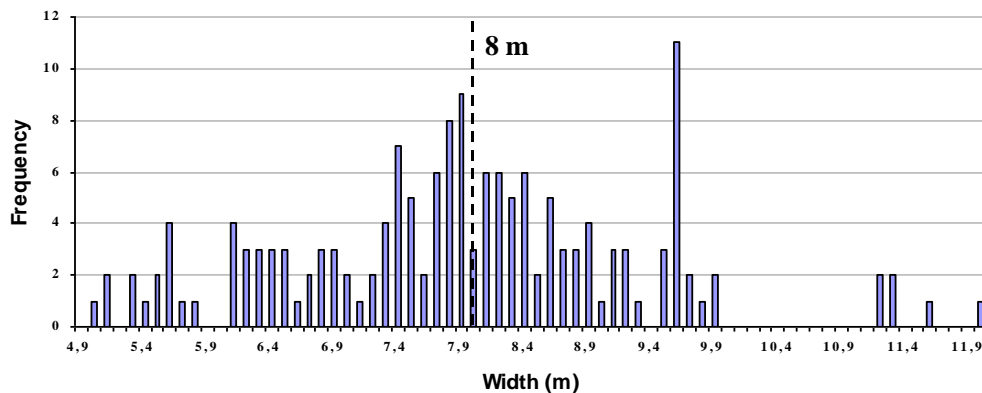

Figure 1. Frequency distribution of the widths generated by Genitronic

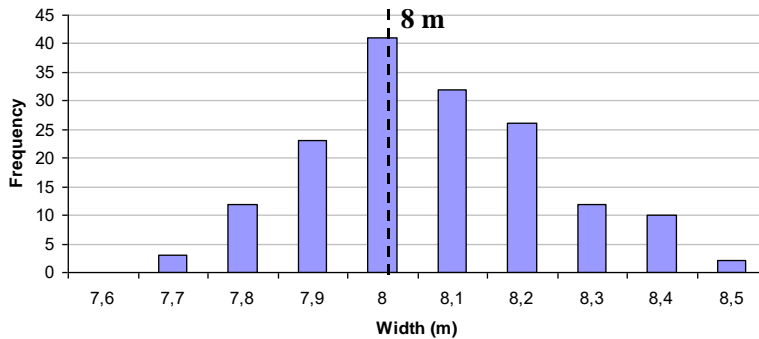

Figure 2. Frequency distribution of the widths generated by John Deere

The Genitronic produces widths generally deviating from the expected and they are highly variable. On the contrary, John Deere generates consistent widths which frequency distribution is of Gaussian type centred about the expected working width (8 m).

### 3.3. Curved line

This mode of functioning seems identical to the straight one: the GPS guiding system bases the building of the tractor's routes on the reference line (AB) and the ordered working width, while minimising the overlapping. To do that, two assumptions could be made:

- The GPS system builds the next route by simple linear translation of the previous curved line (Figure 3),
- The GPS system builds the next route by orthogonal translation of each point of the previous curved line (Figure 4).

Following the first hypothesis, the building of the curved routes by simple linear translation is done perpendicular to the reference straight line AB on a distance equal to the working width (Figure 3). This mode of functioning causes problem in terms of overlapping. Generally the machine (sprayer, fertilizer spreader) works perpendicular to the tractor's trajectory. The more the working axle will deviate from the translation axle, the more the overlapping will be important.

On the other hand, if one retains as working hypothesis that the mode of routes building is realised by orthogonal translation, one notices that the trajectory will be bent a bit more for each new routes. As illustrated on Figure 4, the curved trajectory could be considered as a circle which radius will increase of the working width value for each new route.



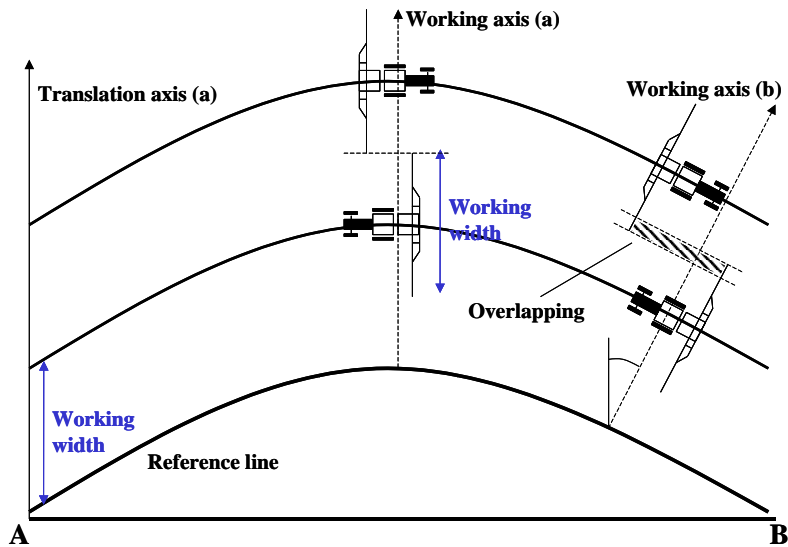

Figure 3: Building of the curved routes by simple linear translation

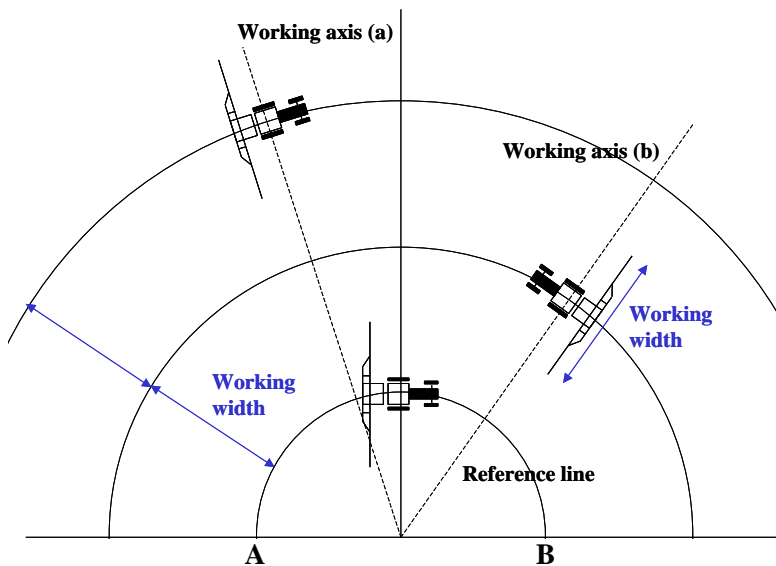

Figure 4. Building of the curved routes by simple orthogonal translation of each point

This mode of functioning causes a bending of the initial curved line. At the end (tending towards infinity), the last route could be theoretically not more curved, but perfectly straight.

As shown by these considerations, the treatment of the data from the trials done for the curved line was not evident. However, a part of the observed values has been exploited and Table 2 gives some descriptive parameters.

The results for curved lines confirm the one obtained for straight lines. Again, one observes that all systems generate, on average, spaces between routes higher than the expected working width (8 or 16 m), excepted for Genitronic.

Table 2. Performances ( $\bar{x}$ ,  $s$ , Min. and Max. in m) of the 6 GPS guiding systems, curved line for 8 and 16 m working widths

Systems	Working width : 8 m				Working width : 16 m			
	Average $\bar{x}$	Standard deviation ( $s$ )	Min.	Max.	Average $\bar{x}$	Standard deviation ( $s$ )	Min.	Max.
Centerline	8.00	0.49	6.10	9.31	16.49	0.41	15.86	17.35
Cultiva	8.02	0.12	7.76	8.23	16.10	0.11	15.80	16.27
Isaguide	8.08	0.16	7.77	8.37	16.16	0.17	15.92	16.72
John Deere	8.03	0.14	7.71	8.32	16.01	0.25	15.62	16.57
Outback	8.11	0.19	7.67	8.70	16.24	0.19	15.95	16.70
Genitronic	7.88	0.88	5.96	10.24	15.84	0.76	14.38	18.57

#### 4. Conclusions

This study allowed to make the following conclusions on the precision and the usefulness of the GPS guiding systems.

- The announced precision is often on the rendezvous and for some systems is yet better (overlapping or gap < 2 %). But we don't have to forget that the results, sometimes very good, are averages and that the deviations could be occasionally important.
- Without using GPS guiding systems, the overlapping could reach from 2 to 8 %, right from the sowing of the crops (wheat and barley).
- The results allow us to consider the GPS guiding systems really useful and adapted for the agrochemicals application (fertilizer and pesticides), or to the use of large machines.
- A specific protocol should be developed for the study of the curved line mode of functioning.

#### References

- Beguyot Ph., Chevalier B., Rothova H. 2004. Le GPS en agriculture. Principes, applications et essais comparatifs. Educagri, 135 p.
- Deny F. 2002. Mise au point d'une technique pour étudier le comportement alimentaire des moutons en milieu hétérogène. ISI 2002, 75 p.
- Freycon V. 1996. Les GPS : Principes de fonctionnement et conseils d'utilisation. CIRAD, Montpellier, 25 p.
- Dana P-H. 2000. Global positioning system overview.  
[http://www.colorado.edu/geography/gcraft/notes/gps/gps\\_f.html](http://www.colorado.edu/geography/gcraft/notes/gps/gps_f.html)

## **DETERMINATION OF OPTIMUM TIMING FOR CHEMICAL CONTROL OF CUTWORMS USING LIGHT TRAPS AND PHEROMONE TRAPS**

*Magdalena Jakubowska*

*Plant Protection Institute, Department of Forecasting and Registration Pests and Diseases*

*Miczurina 20, 60-318 Poznań, Poland*

*e-mail: M.Jakubowska@ior.poznan.pl*

**Keyword:** cutworms, mass occurrence, forecasting, light trap, pheromone trap

### **Introduction**

Larvae of the lepidopterous insect (*Agrotis segetum* Den. & Schiff.) and (*A. exclamationis* L.) are common pest insects in Poland. Larvae are feeding on the foliage of the sugar beet plants and can completely defoliate and kill a plant. Cutworms are ground pests feeding on numerous arable crops, vegetables, ornamentals and tree fruits from orchards as well as plants growing in nurseries. Larvae are burrowing in the soil during the day and come out to feed at night. These insects cause significant yield losses on various crops every year (Wiech K., Kałmuk J., Pawelec A. 2001). The seedlings and plants at the late growth stage are more vulnerable to pest injuries. Sugar beet yield loss resulting from the pest injuries ranges from 10% to 30% (Walczak F., Jakubowska M. 2001).

The main cause of the loss in the yield is the chemical applications at incorrect time. Generally the control of these pests is difficult and available methods do not always provide efficient results due to the life cycle of cutworms. Caterpillars are most active at night and usually during daylight hours buried below the soil surface. Monitoring the population of cutworm moth with light traps and pheromone traps in controlled conditions gives data for accurate detection of pest occurrence on a particular crop, its number and identification of harmful growth stages (Olszak R.W. 1999). The use of many traps for the cutworm moth might be very useful in establishing an optimal timing for chemical control against cutworms (Walczak F. 1998, Wiech K., Kałmuk J., Pawelec A. 2001, Płuciennik Z., Olszak R.W. 2002, Rogowska M. 2005).

The aim of investigation was the determination of optimum timing for chemical control treatments of cutworms using light traps and pheromone traps.

### **Material and methods**

In the years 2005-2006 dynamics of flight of turnip moth (*A. segetum*) and heart and dart cutworms on sugar beet crop was monitored in the field trials. For catching the butterflies light traps (Polish brand) and pheromone traps

(Medchem Co.) were located at the Plant Protection Institute (PPI) Research Station Winna Góra and the Sugar Beet Breeding Research Station in Więclawice. The traps were set up on the selected experimental plots of sugar beet at the growth stage BBCH 12-30 from May to October. The number of caught males was recorded three times per week. Simultaneously, the observations of the life cycles of both species were carried out in semi-natural conditions in insectariums and on micro-plots. The observations of moths and caterpillar development were performed every 2-3 days. Due to the difficulties with rearing turnip moth in semi-natural conditions, only the development of heart and dart cutworm until a stage L3 was recorded (control of both cutworms is performed at the same time because they have similar life cycle).

Moreover, in the year 2006 on studied experimental plots of sugar beet (at two places) observations were done. On that bases cutworm harmfulness and chemical control was done. The time of insecticide application was chosen according to the beginning of flying butterflies. Karate Zeon 050 SC was applied to chemical control against cutworm with dose recommended by PPI. The collected cutworm imagines were identified and quantitatively characterized. The results from the growth chamber studies were analyzed statistically. The Freeman-Tukey test at the level  $p = 0.05$  was applied to evaluate the significant differences.

## **Results and discussion**

Based on the results it was concluded that the population density of turnip moth fluctuated in the years of conducted studies and *A. segetum* individuals were more numerous on the field plots in Więclawice and in the Research Station Winna Góra. The greatest number of moths trapped was in 2006 (277 individuals) and the least in 2005 (158 individuals). In each year butterflies were more active at the end of May. There were two periods with higher amount of males: first in June/July (I generation) and second in August/September (II generation).

Regular flights of heart and dart cutworm were first detected around May 25<sup>th</sup>. The time of imago flights was short, i.e. at the end of July. The highest number of butterflies caught with the light trap was in Więclawice and Winna Góra in the year 2006 (176 individuals).

The data showed that high temperatures positively influence the number of trapped insects. The numbers of caught cutworm vary in direct proportion to temperature course. In both places the obtained results showed that at the temperature 16-18°C at night (23-2 h), the number of captured butterflies was higher. There are also other factors which influence the efficiency of the light traps for collection of insect material. The course of temperature fluctuations

during the night plays a major role. In August 2005 it was observed that at lower temperatures with heavy rainfall the butterflies were less active.

Development of heart and dart cutworm eggs in natural conditions and on experimental plots was observed too. In the years 2005-2006 the incubation period began from June 12-18<sup>th</sup> and lasted for 7-10 days. First caterpillars were noticed on June 20-28<sup>th</sup>. The observations ended when the caterpillars burrowed into soil at ground level near sugar beet roots (from mid-July until the end of August). Development of heart and dart cutworm from egg to burrowed caterpillars into soil was observed for 36 individuals in 2006 year and 28 individuals in 2005 year.

In order to evaluate cutworm occurrence and their chemical control, in year 2006 in period of intensive the butterflies flights, the numerous field observations were performed. In aim was of harmfulness the occurrence of cutworm and his chemical control treatments. Optimal timing for chemical control was determined in Winna Góra on July 4<sup>th</sup> and Wicławice on July 6<sup>th</sup>. Moreover, the beginning of *Cornus sanguinea* L. (indicator plant) blooming was taken into account. The chemical treatments were done between 8 and 13 June. At the time controlled caterpillars on experimental plots were in stage developmental L2/L3.

## Conclusions

1. Efficiency of cutworm flights toward light depends on the rate of fair temperature at sunset to a mean temperature of a particular phenological period. In the studies high temperature positively influenced the number of caught butterflies.
2. The differences during vegetation seasons, in case of number as well as dynamics of moth flights, indicated that regular monitoring of cutworms is necessary.
3. The light trap and pheromone trap which were applied on sugar beet plants showed full usefulness to monitoring of cutworms and might be very useful in establishing an optimal time for treatments.
4. Time of first catch butterflies both species of cutworms are similar to beginning of *Cornus sanguinea* L. blooming.

## References

- Olszak R.W. 1999. Monitoring jako zasada racjonalnej ochrony roślin sadowniczych. Prog.Plant Protection/Post. Ochr. Roślin 39, pp. 298-304.
- Pluciennik Z., Olszak R.W. 2002. Fenologia lotu zwójki bukówecki (*Pandemis heparyna* Den.& Schiff.) w sadach jabłoniowych w niektórych rejonach Polski. Prog.Plant Protection/Post. Ochr. Roślin 42, pp. 931-934.
- Rogowska M. 2005. Zastosowanie nowej pułapki feromonowej do monitorowania nalotu piętnówki kapustnicy (*Maestra brassicae* L.) występującej na warzywach kapustowatych. Ogólnopol. Konf. Upowszech. „Nauka – praktyce”. Skierniewice, 20.10.2005, Inst. Warz.
- Walczak F. 1998. Pułapka feromonowa – metoda sygnalizacji wybranych roślin warzywnych. Prog.Plant Protection/Post. Ochr. Roślin 38, pp. 55-357.
- Walczak F., Jakubowska M. 2001. Wzrost szkodliwości rolnic (*Agrotinae*) w Polsce. Prog.Plant Protection/Post. Ochr. Roślin 41, pp. 386-390.
- Wiech K., Kałmuk J., Pawelec A. 2001. Wykorzystanie pułapek feromonowych do prognozowania niektórych szkodników warzyw. Prog.Plant Protection/Post. Ochr. Roślin 41, pp. 450-453.

## **ASSESSMENT OF THE TECHNICAL INFRASTRUCTURE ACCORDING TO THE LEVEL OF DEVELOPMENT**

*Zuzanna Jarosz*

*Institute of Soil Science and Plant Cultivation – State Research Institute, Pulawy, POLAND*

*e-mail: bloch@iung.pulawy.pl*

**Keywords:** technical infrastructure, water supply system, sewer system, wastewater treatment plants

### **Introduction**

Farms and rural areas constitute one of the most important elements of the Polish socio-economic reality, and at the same time, one of the most difficult problems for the country is solving the process of development. For rural areas, their sustainable development is the long-term aim. Through it, simultaneous action can be understood in a few directions: a diversity of farms and villages, curbing unemployment along with improvements in both the social living conditions of the rural population and the function of economic and social interactions. The transition from a centrally planned economy to a market economy has multiple consequences for conditions of social living in both the agricultural population and the non-agricultural settlements of rural populations.

The success of programs in the development of rural areas depends largely on the improvement in the state of the technical infrastructure. The level of infrastructure constitutes a crucial factor for the modernisation and the intensification of farming, and influences the standard of living of the rural population. The level of infrastructure depends on the attractiveness and modernity of the region, administrative district, or village; this decides about its chances and barriers for the future possible development of the region (Jeznach et al., 2001; Ostrowski, 1996).

In Poland, the neglect of the infrastructure in rural areas has always been high. These problems were noticed by Ziętara (1992), where he saw that there was an obvious lack of providing the rural areas with infrastructure which was a noticeable weak point of Polish farming. Admittedly, the development potentialities became more beneficial for village investment, which appeared from this range, it is still not only a characteristic of infrastructure neglect, but also the strong regional diversity (Zawadzki, 1993). Investments are being carried out selectively and they do not have a comprehensive character.

The aim of this work was to perform a comparative analysis of the level of development for the technical infrastructure from a spatial perspective, i.e. in the profile of regions.

## **Methods**

The basic sources of information were statistical data from GUS (Central Statistical Office), put together in a zoning arrangement of the division at present in these regions. These were assessed into seven diagnostic features regarding their characteristic state of technical infrastructure, and the housing was chosen in rural areas of individual regions:

- X<sub>1</sub> – total density of kilometre roads per 100 square kilometres,
- X<sub>2</sub> – total density of kilometre water supply system per 100 square km,
- X<sub>3</sub> – total density of kilometre sewer system per 100 square kilometres,
- X<sub>4</sub> – total recipients of mains gas per 1000 inhabitants,
- X<sub>5</sub> – total floor surface of flats in square metres per capita,
- X<sub>6</sub> – collective wastewater treatment plants,
- X<sub>7</sub> – individual wastewater treatment plants.

In order to enable the comparability of these features it was subjected to a standardisation. Many different methods of constructing measurements of the development exist (Bański, 2001; Nowak, 1996). In the study, a simple method was used in the form of an average standardised value of diagnostic features. The interpretation of the value of the measure is as follows: the region is characterised by a higher level of development. In this way, every region was described with one value, which determines the level of development of the infrastructure in its area.

## **Results and discussion**

The dispersal of farm buildings and issues from these higher costs of building infrastructures in the rural areas is related to small income by agriculture and high unemployment – it is the main cause of the development's brake when comparing with towns. In many places, one observes a lack of adequate services, the necessity to modernize electricity-line and to develop lower level water line and sewerage systems. These difficulties set back development of extra-agricultural functions in rural areas.

The analysis showed that inter-regional variability for the level of technical infrastructure was very high. The best-developed road network [in kilometre per 100 square kilometre] was found in the Małopolskie (132.0) and Śląskie (128.5) regions, where the density of roads, was almost three times larger than in the region of Warmińsko – mazurskie and Zachodniopomorskie (Table 1). Bigger disproportions were found in the range of the waterworks



and sewer systems. The largest density of water supply systems [in kilometre per 100 square kilometre], appear in the areas of the regions: Śląskie (102.2), Kujawsko – pomorskie (100.0) and Łódzkie (98.9), and the smallest in the region of Zachodniopomorskie (26.1) and Lubuskie (29.2). In the spatial arrangement, the largest concentration of sewer systems [in kilometre per 100 square kilometre] was found in the country's regions: Podkarpackie, Małopolskie and Śląskie. This results from the development of urban and larger investment outlays for environmental protection in the regions. One of the most important technical infrastructure factors, which influence the attractiveness of rural areas, is a large disproportion between the lengths of water supply, which contradicts the length of the sewer system. The largest differences between the length of the waterworks and sewer system were observed in the regions: Kujawsko- pomorskie, Łódzkie and Śląskie. In the rural areas, there are 2,366 collective wastewater treatment plants, the most in regions: Wielkopolskie and Zachodniopomorskie. An alternative for the development of high cost sewerage systems and investment on collective wastewater treatment plants is the building of small, individual localised wastewater treatment plants. The highest quantity was affirmed in Małopolskie (6,387) and Podkarpackie (5,401) regions. In 2005, a higher density of the gas mains [in kilometre per 100 square kilometre] was noted in the Podkarpackie (152.4) and Małopolskie (124.6) regions and the lowest in regions: Kujawsko - pomorskie, Podlasie, and Warmińsko – mazurskie.

Table 1. Indicators for the development level of the technical infrastructure in regions (2005)

Regions	X <sub>1</sub>	X <sub>2</sub>	X <sub>3</sub>	X <sub>4</sub>	X <sub>5</sub>	X <sub>6</sub>	X <sub>7</sub>
Dolnośląskie	75.4	47.2	15.5	29.2	24.9	138	3187
Kujawsko – pomorskie	69.1	100.0	14.5	4.9	21.8	126	3602
Lubelskie	66.5	62.4	5.9	33.5	25.1	199	3573
Lubuskie	49.0	29.2	5.1	24.9	23.7	66	193
Łódzkie	79.1	98.9	6.3	12.2	26.0	129	1732
Małopolskie	132.0	89.1	27.5	124.6	23.8	209	6387
Mazowieckie	70.4	80.4	6.9	45.3	25.0	73	1386
Opolskie	80.2	59.5	11.2	12.5	26.6	55	317
Podkarpackie	70.3	62.0	39.2	152.4	22.6	208	5401
Podlaskie	49.1	49.1	4.3	8.6	27.0	78	1757
Pomorskie	52.0	52.3	16.2	12.4	22.4	181	481
Śląskie	128.5	102.2	25.5	82.3	27.4	110	736
Świętokrzyskie	96.0	85.5	13.1	25.9	23.7	87	269
Warmińsko – mazurskie	45.3	42.9	8.7	7.7	21.2	162	433
Wielkopolskie	72.4	79.3	12.3	35.3	23.8	300	1453
Zachodniopomorskie	47.8	26.1	9.4	36.8	22.8	245	426

The state of the housing is an element that has an essential influence on the quality of life for people. The basic indicators that determine the housing conditions are the averages of floor surface allocated to one person, and were

found more positively in rural areas than in the whole of the country. The greatest value of this indicator was stated in regions: Śląskie (27.4), Podlaskie (27.0), and Opolskie (26.6), and smallest in Warmińsko – mazurskie (21.2).

Thanks to the applied method, the development level of the technical infrastructure for each region has been characterized by one unique value. (Table 2).

Table 2. Value the regional development

Regions	Results
Dolnośląskie	0.00
Kujawsko – pomorskie	-0.05
Lubelskie	0.08
Lubuskie	-0.87
Łódzkie	0.09
Małopolskie	1.35
Mazowieckie	-0.16
Opolskie	-0.27
Podkarpackie	0.95
Podlaskie	-0.43
Pomorskie	-0.44
Śląskie	0.89
Świętokrzyskie	-0.12
Warmińsko – mazurskie	-0.80
Wielkopolskie	0.26
Zachodniopomorskie	-0.48

The Lubuskie region obtain the worst value. Małopolskie, Podkarpackie, and Śląskie regions get the highest score in terms of development. Ranking from –0.87 to 1.35, the development level of technical infrastructure and public housing present a high variability from region to region..

## Conclusion

The analysis for the state and the development level of the infrastructure can be a benefit in accessing the disproportion. In addition, this analysis can help in stimulating the activity of the self-government civil service into developmental processes of individual administrative districts. This is in order to eliminate the disproportion between regions; increasing their accessibility to basic elements of the technical infrastructure, conditioning the appropriate quality of life and the development of the entire region. It is one of the resources for finding investors for depositing their capital in a given area. Not only is it conditioning the development of the business activity, but also by its development and functioning, it is lowering the level of unemployment in rural areas.

## References

- Bański J. 2001. Problem areas in Polish agriculture. *Geographia Polonica*, 74, 1, IGiPZ PAN, Warszawa, pp. 47-63.
- Jeznach M., Tul A., Jeznach J., Krajewski K., Świątkowska M., Świstak E., Bilaska B., Wierzbicki K., Panasiuk G. 2001. Potrzeby kształtowania infrastruktury wsi na terenach chronionych a rozwój gospodarczy gmin kampinoskich. *Zeszyty Naukowe AR Kraków*, pp. 377.
- Nowak E. 1996. Statystyczne stadium rozwoju rolnictwa województwa lubelskiego. UMCS, Lublin.
- Ostrowski L. 1996. Infrastruktura techniczna obszarów wiejskich. Stan i perspektywy. IERiGŻ Warszawa.
- Ziętara W. 1992. Analyse der bisherigen Entwicklung in der aktuellen Agrarprobleme der polnischen Landwirtschaft. Band 70, Verlag Paul Parey, Hamburg und Berlin.
- Zawadzki W. 1993. Infrastruktura techniczna a regionalne zróżnicowanie terenów wiejskich. *Zag. Ekon. Rol.*, 3, pp. 30-42.

## **AGRICULTURAL TECHNOLOGIES AND WORK SAFETY**

*Tadeusz Juliszewski*

*Agricultural University in Krakow, Department of Machinery Management, Ergonomics and Fundamentals of Agriculture, Kraków, POLAND*

*e-mail: juliszewski@ar.krakow.pl*

**Keywords:** work safety; ergonomics, agricultural technology

### **Abstract**

Work safety is generally defined as the performance of work in conditions not threatening to human health and safety – in this case it applies to agriculture.

Work technology denotes all methods for the manufacturing and processing of raw materials and products. In agriculture these are mainly products of biological origin (manufactured from plants and animals).

Changes in work technologies have clearly increased safety for people employed in agriculture, which is reflected in the decreasing annual accident ratio registered by the Agricultural Social Security Fund.

### **Some impressive examples:**

**The tractor** is the basic agricultural machine that has been used in agriculture for 100 years. Although it's contemporary general design is still similar to the design by Henry Ford (who started tractor mass production in 1917), it differs significantly in terms of its operation and servicing. Here are the basic differences which have contributed to increased driver safety:

- The introduction of cabs and cages have resulted in a 10-fold reduction in injuries caused by tractor's overturning (before cages were introduced, there was one tractor driver fatality per 10,000 tractors per year – nowadays there is only one fatality per 100,000 tractors in operation),
- The introduction of soundproof cabs and the use of hearing protection (achieved by training) considerably decreased the percentage of tractor drivers with hearing problems (as late as in the 70-s, studies carried out in the former East Germany indicated hearing loss in more than ten percent of tractor drivers, caused by exposure to noise).
- The introduction of suspension systems for seats (or cabs) fitted to the vibration spectrum typical of field tractor operations has resulted in a significant reduction in vibration impact on the driver.
- Tight, air-conditioned cabs have reduced the risk of harmful effects of toxic substances (herbicides) and dust on the operator and eased the arduous work conditions in excessively hot or cold microclimates.

Automatic fodder feeding and faeces removal has reduced the need for long residence in **farm buildings**, where although the harmful gas concentration

(ammonia, hydrogen sulphide) did not represent a risk in terms of poisoning, it was simply unpleasant.

Undoubtedly, the introduction of new technologies have contributed to animal welfare, i.e. providing a microclimate and adequate space for a given livestock species indirectly improved work conditions and human safety. In addition, the hygiene requirements for milk production in big farms have led to construction of cowsheds where the conditions resemble more state-of-the-art industrial shop floors and they have little in common with the stereotypical image of animal breeding.

Technological changes are the most important: they have improved safety, but they apply mainly to **transport**, especially to material loading and unloading in agriculture. It should be noted here that approximately from 12 to 100 tons of plant materials (e.g. corn, straw, potatoes, beet, hay), fertilisers, organic substances (e.g. manure, dunghill) and herbicides per one hectare of the cultivated land are handled every year. Although plant production was much lower, almost everything was loaded and unloaded manually. Undoubtedly, years of hard work set its mark on anybody working in agriculture.

### **Unsolved problems**

The family nature of many farms means that children, young adults and the elderly are involved in the work. Scientific research in Poland and abroad indicates that the risk of an injury is considerably higher in this case. In the case of children and young adults, the tragic consequences of an accident often destroy their life. However, it is not possible to eliminate the risk of accidents in the rural population.

The blind area for the operator around a tractor or harvester is considerably larger than in the case of a car or truck driver and is the cause of many accidents during manoeuvring in the barnyard or in the field.

However, we have still not been able to construct a system for signalling the risk of 'upturning', for example during work on a sloped area; a system that could react much quicker than the driver, so protecting them against capsizing. Still, efforts to build such a system, both in Poland and abroad, do not meet the requirements for their practical implementation.

However, it seems that the fundamental problem yet to be solved is the fact, that for a considerable percentage of people working in agriculture, knowledge about principles of work safety is fragmentary. Undertaking hazardous work in this environment is more common than in other sectors, unfortunately, often with tragic consequences. That is why the training and preventive measures promoted by such organizations as the Agricultural Social Security Fund, the National Labour Inspection and other institutions cannot be overestimated.

We should also mention another significant problem. The number of disabled people in agriculture is so high that the problem of adapting machines and tools for their abilities still requires action to help them to take up work. Ensuring safety conditions for work is more significant than for able-bodied person, and it

is not a matter of sympathy but rather another methodological approach in designing and constructing the work place.

### **New problems**

Agriculture, like any other branch of industry, changes not only production technologies, but also the range of its products. The guidelines of agricultural policy define the need to produce inexpensive and healthy food, as well as industrial raw materials by agriculture in Europe and other parts of the world.

It is expected that the agriculture will produce an increasing share of renewable energy sources (e.g. biogas, biofuels), more so than it does today, being not only the place where raw materials (biomass) are produced, but where they are also processed. In turn, the application of IT technologies is a matter of the success – or failure – of the farm in terms of the market economy.

The production of biogas, widespread in Western Europe (especially in Germany), is connected with a considerable risk of explosion and poisoning resulting from the occurrence of such gases as methane, ammonia or hydrogen sulphide in the work place. The widespread biogas production technology will require staff training in respect to safety and – obviously – the availability on the market of machines approved in respect to safety of their construction and operation.

Such poisonous substances as methanol or potassium hydroxide (KOH) are employed in the production of diesel engines (biodiesel) from rape oil. Current national regulations permit the production of 100 litres of biofuel per 1 hectare of the cultivated land for the farm's need. Probably only a fraction of farmers will take up this production and as a result the knowledge of biofuel production technology as well the conditions required for its safe production, handling and storage should be propagated.

Nearly each modern agricultural machine – the tractor, harvester, sprayer, spraying machine, etc. – is furnished with an onboard computer. Unfortunately, procedures for using this electronic equipment are not standardized. The same or similar operations require the initialising (e.g. pressing) of different buttons on the control panel. Undoubtedly, standardization (unification) of operational procedures would facilitate work, especially if it reduces the risk of accidental failure due to errors in machine operation. It is of course more often a question of the safety of a machine's operation rather than the safety of the operator, which is often a forgotten aspect in regard to work safety analysis.

## **BIOMASS POTENTIAL IN THE AREA OF LUBLIN PROVINCE**

*Magdalena Kachel-Jakubowska*

*Agricultural University in Lublin, Department of Machinery Exploitation and Management  
in Agricultural Engineering, Lublin, POLAND*

*e-mail: magdalena.kacheljakubowska@ar.lublin.pl*

**Keywords:** biomass, wood, straw, biomass potential, Lublin Province

### **Abstract**

The territory of Lublin Province has a great potential of agricultural development, especially concerning huge usage possibilities of renewable resources such as solar, wind and hydro-energy as well as biomass.

It was estimated that the annual energy potential of biomass wastage produced in Agriculture and Forestry in the area of Lublin roughly amounts to 19 PJ and in the whole country to 195 PJ. It is possible to increase those numbers by cultivation of grain crops, oil plants as well as energy-efficient plants such as *Salix Viminalis*. The under-developed lands, which are still growing in numbers up to 7.3%, could be used for that purpose.

### **Introduction**

Industrial revolution caused intense increase in demand for energy and that was the reason for higher consumption of fossil liquid fuels. In the following years the whole energy economy was based on constant extraction of coal, crude oil and natural gas. The large scale of extraction and uncontrolled abuse led to multiple threats to the environment:

- primary energy sources are unrenovable and doomed to gradual exhaustion (Table 1.)
- harmful emissions during combustion processes are environmentally unfavourable and cause greenhouse effect.

Table 1. Fossil fuels resources (Lewandowski 2002)

Energy Carrier	Reserve			Year of exhaustion	
	Unit	Known	Presumed	Known	Presumed
Coal	Pg	600	16400	after 2060	after 2200
Crude oil	Pg	82.4	192.6	2020	2050
Natural gas	Tm <sup>3</sup>	65	339	2012	after 2060
Uranium	Pg	1.02	1.08	2060	2200

In order to prevent those negative effects various steps were taken on the international scene, which led to creation of numerous documents (e.g. Report Rome-1973 and The Rio de Janeiro Convention on biological diversity-1992, Kyoto Protocol on Accounting and Assigned Amounts-1997)

Significant meaning for Poland have international conventions concerning atmosphere protection, especially United Nations Framework Convention on Climate Change and Kyoto Protocol which oblige Poland to reduce emissions in combustion gases by 6% in years 2008-2012 in comparison to the year 1988 (Paczona 2003).

The advantages of exploitation of renewable energy sources such as: solar energy, wind power, hydro-power and geothermic biomass energy have local character in the way of considerable increase of energy safety, new work places creation, regional development promotion, as well as global character when taking under consideration the environmental advantages of reduced carbon dioxide and nitrogen oxides emissions.

Special attention should be focused on biomass because of the fact that production of single energy unit out of biomass needs far less investments than that out of a traditional energy carrier (Roszkowski 2001). Biomass, depending on its chemical composition, could be used for; direct combustion (prepared as briquettes or pellets), biogas production or liquid fuels transformation (biodiesel or bioethanol). One of the greatest advantages of biomass is low sulphur dioxide emission during combustion process and the level of carbon dioxide, which, thanks to photosynthesis process, is close to zero (Kuś 2004).

### **The specificity of Lublin region**

Lublin Province is located in the east part of Poland. This large region of over 25 000 km<sup>2</sup>, which is about 8% of the whole country area, is divided into 24 counties and 213 communes. Sadly the Province belongs to one of the least populated and urbanized parts of the country (14<sup>th</sup> place in rank). The average population density is 89 people per 1 km<sup>2</sup>, which gives it the 12<sup>th</sup> place in rank (71.3% of country average) (www. RPOWL 2007). Regarding agricultural side of region it is necessary to take under consideration enormous land resources i.e. cropland (58.9% of the whole area of Province). among which arable land (47%) is dominating, including waste land (7.3% of arable land), forests and woodland (23%), meadows and grazing land (11%), orchards (2.3%) as well as historical processes and several natural circumstances such as beneficial for agricultural production -climate and soil conditions (GUS 2007, GUS.R. 2006, Grzybek 2006, RSIWL 2004). Excessive portioning of land as well as lack of specialization are the main factors reducing the real value of Agriculture in the area. Therefore the growth of ecological farming might be one of the alternative forms of farm restructuring and new work places creation. Attention should be naturally focused on biomass, which as a reliable and continuously renewable resource can make a significant contribution to satisfying the needs of society for energy (RPOWL 2007).



## Biomass potential and usage

Biomass concept consists of biodegradable product fractions, agricultural wastes and residues (vegetable and animal matters), woodlands and derived industries residues as well as biodegradable fractions from industrial and agricultural waste products.

Concerning the state of matter biofuels derived from biomass can be divide into: solid, liquid (bioethanol, biodiesel) and biogas. The energy value, of mentioned above, depends on the calorific value, moistness, density, degree of flabbiness (Table 2.).

Table 2. Physical-chemical values of straw, woodland wastes and fossil fuels (TCfT 1998).

Parameters	Units	Yellow straw	Grey straw	Felling site products	Coal	Natural gas
Heat of combustion	MJ/Kg	18.2	18.7	19.4	32	48
Labor calorific value	MJ/Kg	14.4	15	10.4	25	48
Moisture	%	10-20	10-20	40	12	0
Content of ashes	% d.w.	4	3	0.6-1.5	12	0
Content of light constituents	% d.w.	>70	>70	>70	25	100
Carbon	% d.w.	42	43	50	59	75
Hydrogen	% d.w.	5	5.2	6	3.5	24
Oxygen	% d.w.	37	38	43	7.3	0.9
Chlorine	% d.w.	0.75	0.2	0.02	0.08	-
Nitrogen	% d.w.	0.35	0.41	0.3	1	0.9
Sulphur	% d.w.	0.16	0.13	0.05	0.8	0

The following sources of biomass are of a great importance concerning domestic conditions as well as the specificity of Lublin region:

- Wood from forests, cuttings, orchards, special cultivations and waste wood from timber industry
- Cultivated plants plantations for energy sources (*Salix Viminalis*, *Agrostis gigantea*, *Phragmites australis*, *Sida hermaphrodita*)
- Oil plants seeds exposed to pressing process, esterification, and transesterification
- Potatoes, grain crops, sugar beets and the like, transformed to ethanol and added to petrol
- Organic wastes and refuses in the form of: straw (from rye, wheat, rape, buckwheat and corn), agricultural and food industry wastes, dung stead or farm manure used in methane fermentation, municipal wastes and industrial wastes (paper and cellulose industry) (Janowicz 2006).

To make the most of biomass under domestic conditions we ought to concentrate on heat production. Biomass used as energy source in direct

combustion process is transformed into liquid or gas fuels. In order to convert biomass into energy carrier we can use physical, chemical or biochemical methods. Apart from direct combustion process and gaining chemical energy there is a possibility of thermo-chemical conversion of biomass into much higher quality fuel as for the energy consumer point of view (Kaltschmitt 2001).

The annual potential of energy wastes from biomass produced in Agriculture and Forestry in 2006 was estimated as 195 PJ for the whole country and 19 PJ for Lublin Province.

## Wood

Major quantities of biomass from wood wastes are being produced by timber industry. It was estimated that, for the year 2005, 29 288 m<sup>3</sup> of wood were obtained from governmental and private forests on the territory of Poland and 1421.1 m<sup>3</sup> in Lublin region (aside from National Parks) (Table 3) (GUS.L. 2006).

Concerning Lublin Province, the best advantageous possibilities of wood exploitation exist in Bialski, Biłgorajski, Włodawski and Zamojski Counties, as for immense areas of forests. In the future, up to the year 2010, cultivation of special energy-efficient plants might become an interesting source for power industry and the growing number of abandoned land and fallows (7.3%) could be used for that purpose (Gradziuk 2004).

Table 3. Wood obtained from 100 ha of forests in 2005 (GUS.L. 2006)

Years province	Total		Public forests				Private forests
	m <sup>3</sup>	Province place in rank	Total	Belonging to the treasury			
				Total	Belonging to		
					Governmental forests	National parks	
m <sup>3</sup>							
Poland ...1995	235.8	-	264.1	265.1	273.4	123.2	98.4
Poland ...2000	293.6	-	335.0	336.6	346.6	127.6	94.0
Poland ...2001	281.3	-	324.7	326.6	336.9	94.7	74.7
Poland ...2002	304.3	-	353.5	355.6	366.3	105.9	71.4
Poland ...2003	321.4	-	373.9	376.2	387.3	115.7	73.6
Poland ...2004	339.1	-	394.0	396.4	408.3	107.2	80.6
Poland ...2005	<b>330.3</b>	-	<b>385.9</b>	<b>388.5</b>	<b>399.9</b>	<b>108.2</b>	<b>70.7</b>
Lublin Province	256.2	14	372.8	373.7	389.5	154.7	74.9

## Straw

Generally straw is one of the most accessible sources of biomass. In the past few years, straw exceeded the target figures on many farms and so the surplus was used as an energy source. Straw from all kinds of crops and oil plants might be used for energy purposes. At present straw from rye, wheat, rape, buckwheat and corn rachis are preferable and mostly used. Though we

should remember that specification and possibilities of straw usage for energy purpose could be adequate only if we diminish the number of harvested crops by its consumption in Agriculture (first of all liter and fodder and also fertilization purposes to keep steady balance of adaphic organic matter) (Gradziuk 2004, Grzybek 2006).

The analysis estimates that, depending on the year of cultivation, 540 000 ton up to 760 000 ton of straw in Lublin Province could be used for energy purpose. In Ryki and Łuków Counties the whole produced straw were used in animal production, and in the other Counties the quantity of straw for possible energy usage was hovering around 6000 ton (Gradziuk 2004, Kuś 2004).

## **Conclusions**

1. Unprofitable economy structure as well as low expenditures for modernization is causing the fact that Lublin Province has slower growth rate of economic progress than the rest of the country. Attention should be focused on biomass which, as reliable and renewable energy resource is the proper and right direction for the future progress.
2. Taking under consideration agricultural character of Lublin Province there is a great possibility of cultivation of energy-efficient species. Under-developed lands and fallows, which are bigger part of arable land (7.3%) may also be used for that purpose.
3. Plantations for energy purposes offer business possibilities to agricultural enterprises (selling straw to local power stations) create new work places as well as may help to make better use of the land.

## **References**

- Główny Urząd Statystyczny, Leśnictwo 2006  
Główny Urząd Statystyczny, Rolnictwo 2006  
Gradziuk P. 2004. Potencjał wykorzystania biomasy na cele energetyczne w woj.lubelskim. Eko Energia, pp. 127-142  
Grzybek A. 2006. Zasoby krajowe biopaliw stałych i możliwości ich wykorzystania w aspekcie technicznym i organizacyjnym. Energetyka nr IX, pp. 8-11  
Janowicz L. 2006. Biomasa w Polsce. Energetyka i ekologia  
Kaltschmitt M., Hartmann H. 2001. Energie aus Biomasse: Grundlagen, Techniken und Verfahren, Springer-Verlag  
Kuś J. 2004. Ocena możliwości produkcji biomasy na cele energetyczne na Lubelszczyźnie. Eko Energia, pp. 113-125

- Lewandowski W. 2002. Proekologiczne źródła energii odnawialnej. WN-T, Warszawa.
- Paczosa A. 2003. Zasoby energii odnawialnej w Polsce – regulacje prawne oraz możliwości dofinansowania inwestycji w tej dziedzinie.
- Regionalna Strategia Innowacji województwa lubelskiego. Lublin 2004
- Regionalny Program operacyjny Województwa Lubelskiego na lata 2007-2013, Lublin 2007
- Roszkowski A. 2001. Płynne paliwa roślinne - mrzonki rolników czy ogólna niemożliwość? Wieś Jutra. nr 9, pp. 22-26
- The Central for Biomass Technology, Danmark, 1998 “Straw for energy production. Technology-Environment-Economy”
- Urząd Statystyczny w Lublinie. 2007. Rolnictwo w województwie lubelskim w 2006 r.
- [www.lublin.lasy.gov.pl/1/i/11.php](http://www.lublin.lasy.gov.pl/1/i/11.php)

## **INFLUENCE OF WORKING PARAMETERS ON SPRAY QUALITY OF AIR INCLUSION NOZZLES**

*Milan Koszel*

*Agricultural University in Lublin, Department of Machinery Exploitation and Management  
in Agricultural Engineering, Lublin, POLAND*

*e-mail: milan.koszel@ar.lublin.pl*

**Keywords:** air inclusion nozzles, droplets spectrum, flow rate

### **Introduction**

Misuse of industrial production means can pose a threat to natural environment. In this sphere considerable dangers are related to the use of pesticides whose spraying over cultivated areas requires technically efficient equipment.

Having properly selected work parameters of spraying machines the influence of liquid's physical properties on the quality of its spraying and the impact of field relief on working speed should also be considered apart from problems with droplet spectrum evaluation and drop fall uneven distribution coefficient of sprayed liquid (Sawa, Huyghebaert, Koszel 2003).

The quality of spraying machine performance is affected by several technological, technical and climatic factors, the most important of which include the type of machine, choice of nozzles, appropriate spray parameters, temperature and humidity as well as following the instructions of plant protection agents producers.

### **Methods**

Laboratory tests on the nozzle wear were conducted in the Department of Agricultural Equipment Exploitation and Management in Agricultural Engineering, Agricultural University in Lublin.

New nozzles (LECHLER ID 120-03) of nominal flow rate 1.17 l/min were destroyed. A testing stand with sprayer boom travelling at speeds of 5 km/h, 7 km/h and 9 km/h was used for drop placement on pattern surface. Pattern surface consisted of film strip of the size 100 x 10 cm. Measurements were recorded at the pressures of 3 bars, 5 bars and 7 bars. Tests were performed with 5 repetitions.

The nozzles were destroyed to reach 5% and 10% wear rates, which were calculated by comparing the change in liquid flow rate from each nozzle to the nominal flow rate. Water solution of kaolin was used for destroying nozzles; 9.8 kg of kaolin was added into 150 l of water (Ozkan, Reichard, Ackerman 1992).

## Results

Air inclusion nozzles work at higher pressures than the standard ones (LU). The pressure range is from 3 to 8 bars. Droplet track left by such nozzles can be qualified as large and extra-large (for new nozzles drop track was 445  $\mu\text{m}$ , however, for a nozzle with 10% wear rate it was 469  $\mu\text{m}$ ). On the basis of the tests conducted by Biologischen Bundesanstalt für Land- und Forstwirtschaft (BBA) air inclusion nozzles allow us to limit drift from 50% to 90% (Ganzelmeier 2002).

Analyzing the test results of droplet track as a function of working pressure and speed (Figure 1), it was found that an increase of working speed results in separation of individual droplets and the decrease of liquid volume per hectare.

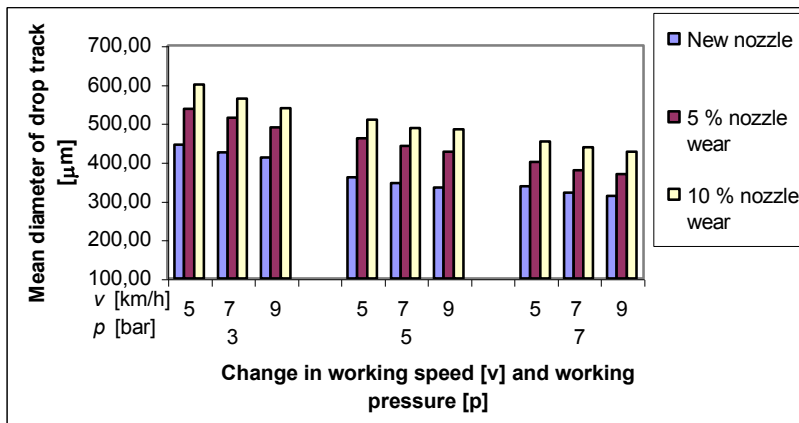

Figure 1. Mean diameter of drop track as a function of the working speed and pressure, for new nozzles, nozzles with 5% and 10% wear rates (LECHLER ID 120-03)

To increase the working pressure results in generating smaller droplets. Consequently, it was found that a rise of the spray coverage coincided with increase in working pressure. However, increase in working speed caused decrease in coverage degree (Figure 2).

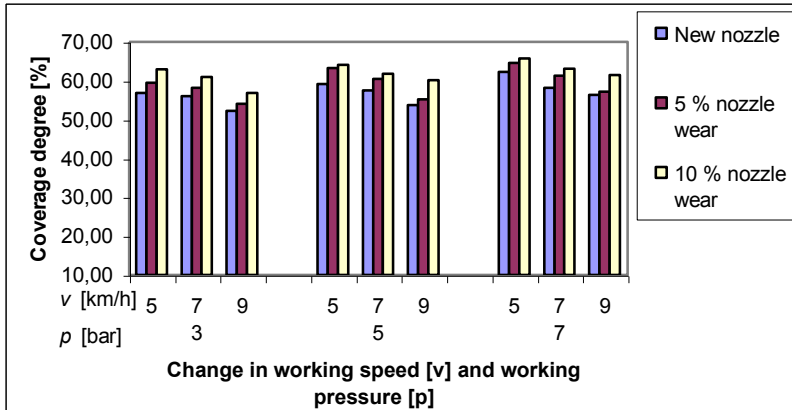

Figure 2. Coverage degree as a function of the working speed and pressure, for new nozzles, nozzles with 5% and 10% wear rates (LECHLER ID 120-03)

Figure 3 shows the evolution of the number of drops per 1 cm<sup>2</sup> as a function of the working pressure and speed.

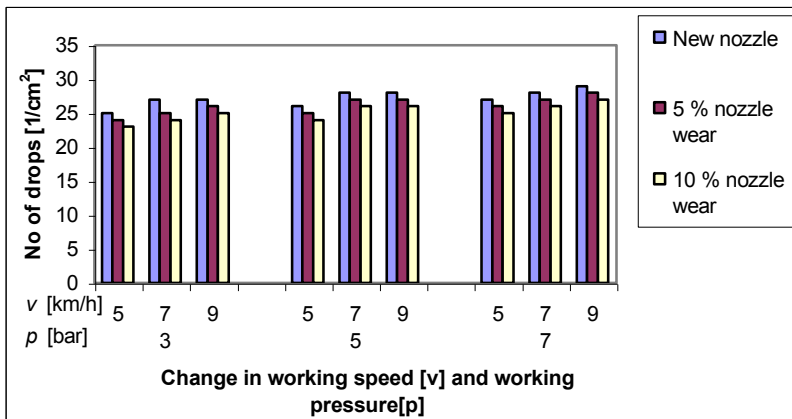

Figure 3. Number of drops per 1 cm<sup>2</sup> as a function of the working speed and pressure, for new nozzles, nozzles with 5% and 10% wear rates (LECHLER ID 120-03)

Excessively low pressure or slow working speed cause merging of drops. This process is especially dangerous when plant protection products are sprayed with high wear rate nozzles.

## Summary

The study confirmed the influence of working pressure and working speed on spray quality. Nozzle wear results in increased flow rate, which causes a larger drop track left on spray surface. Increased nozzle wear results in higher coverage degree. Higher working speed, however, causes decrease in coverage degree. Number of drop tracks decreases with the rise in nozzle wear rate, which is the consequence of merging of drops.

## References

- Ganzelmeier H. 2002. *Europäische und internationale Entwicklungen in der Pflanzenschutztechnik*. Jahrbuch Agrartechnik; VDMA Landtechnik, VDI-MEG, KTBL; Band 14.
- Ozkan H. E., Reichard D. L., Ackerman K. D. 1992. *Effect of orifice wear on spray patterns from fan nozzles*. Transaction of the ASAE, 35, 4.
- Sawa J., Huyghebaert B., Koszel M. 2003. *Parametry pracy opryskiwaczy a jakość oprysku*. Materiały z IV Konferencji: „Racjonalna Technika Ochrony Roślin”. ISiK Skierniewice, 15 – 16 October.



## **THE INFLUENCE OF ANNUAL USE OF BUCKET MILKING MACHINES ON THEIR OPERATING PREVENTION**

*Witold Kowalik*

*Agricultural University in Lublin, Department of Agricultural Machinery, Lublin, POLAND*

*e-mail: witold.kowalik0@neostrada.pl*

**Keywords:** milking machines, operation, services, annual use

### **Introduction**

An effective use of technical devices depends on a proper operation but particularly on a suitable prevention. Users get machines in order to lessen physical effort and work output but on the other hand they do it to increase profits from their usage. These profits guarantee appropriately a long period of machines' functioning, which is significantly a result of proper technical support (Rzeźnik 2006).

An organization of technical background demands knowledge of machines' technical support and their unique work conditions. Machine services are carried out after the passage of given time or after performing suitable amount of work represented in motohours, travelled kilometres, working hours, consumed electric energy (Simariev 1998, Tomczyk 2004). It depends on a capacity and extent of wearing out of the machines influenced by the type of performed work and environment where they function (Żółtowski 1998).

### **The goal & subject of study**

These days some milking machines manufacturers recommend to have milking machines serviced after working for specific number of hours (e.g. De Laval after 1000 hours, Westfalia after 1500 hours). According to our research it is stated that extent of wearing out and present technical condition of a milking machine depend mainly on the time duration of usage. Therefore it is suggested to carry out services with considering this criterion (Kowalik 2006). However, wearing out of the machine elements appears also during work. So the goal of this work was to study an influence of this factor on the technical condition of milking machines.

The subject of study were 23 randomly chosen bucket milking machines, which operating periods lasted approximately from 2 to 30 years, number of worked hours ranked from 2200 to 31147 and annual use ranked from 739 and 1685 hours.

### **The Method**

The measure determining amount of machine work was considered to be its annual use. An influence of this parameter on the machine technical condition was described with the use of the following indicators:

- unreliability:

$$Q = \frac{m}{n} \quad (1)$$

where: m – general number of damage in all machines of the particular group;  
 n – number of all analyzed units of the particular group in good working order at the beginning of the operation;  
 - relative frequency of appearing damages:

$$J = \frac{m}{n \times t} \quad (\text{h}^{-1}) \quad (2)$$

where: t – total working time of all in the group;  
 - average working time per one damage:

$$L = \frac{t}{m} \quad (\text{h}) \quad (3)$$

To do the calculations of these indicators some field research were conducted. They provided the following data:

- the size of the farm dairy herd;
- annual milk production;
- the year of installation of the milking machine;
- number of damages of the machine's particular units during the whole period of the operation;

On the basis of the collected information the number of worked hours of each milking machine for the operating period and the annual use were specified. These calculations allowed us to characterize the milking machines according to the increasing of annual use and to split them up in 4 groups. The basis range was 250 h/year.

The damaged units were: collector – 22 cases of damage, pulsator – 36, underpressure control valve – 9, suction gauge – 5, wash – 3. In further calculations collector was not taken into consideration despite substantial number of damage because it was the result of staff's inattention only.

### **The study results and their analysis**

Variability of analysed reliable indicators depending on one-year machine capacity is presented in figures 1-3. Fig .1 shows the results of the unreliability of machines working from 700 to 1200 hours per year, i.e. first two groups is higher than unreliability of other two groups (1200 – 1700 h/year). It proves that the amount of work of the milking machine is not the main factor which has a destructive influence on its technical condition.

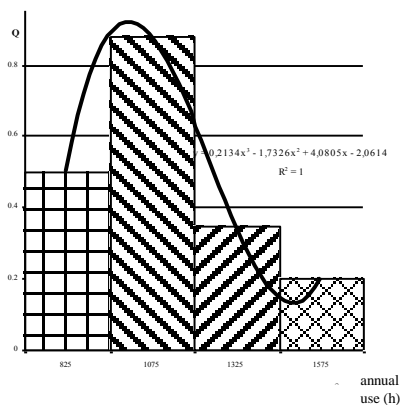

Figure 1. Unreliability of bucket milking machines as a function of annual use

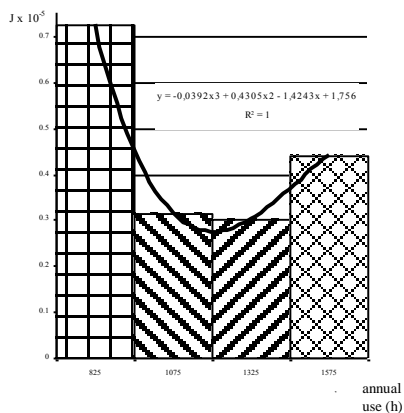

Figure 2. Relative frequency of appearing damages as a function of annual use

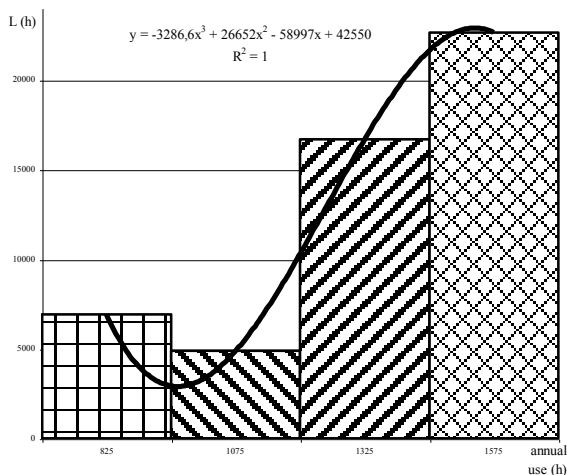

Figure 3. Average working time of bucket milking machines per one damage as a function of annual use

According to the previous studies, the age of a milking machine is one of the main factors (Kowalik, 2006). The confirmation of this conclusion is the dependence of the working time per one damage on one-year machine capacity (Fig. 3). As it is seen from this figure machines working more (1200 – 1700 h/year) are less prone to damage than machines less capable (700 – 1200 h/year). However, the analysis of Fig. 2 shows that for the group with very high annual use (over 1450 h/year) relative frequency of appearing damages increases. It proves that while performing

much work by the machine it is that factor which has a bigger influence on its unreliability, not the age. So the milking machines with very high annual use (over 1450 h/year) should have a kind and frequency of services determined in consideration with the amount of work but below this limit - after the passage of given time.

Introducing only one criterion of setting services for some group of milking machines will always have services done too rarely. With having services done after the passage of given time this group will consist of the milking machines with high annual use. However after performing given amount of work the group will consist of the machines with low capacity.

## **Conclusion**

Conducted research has proved that one-year work capacity of the milking machines is the determining criterion, which defines the range of wearing out and technical condition of the machine. The milking machines working not more than 1450 hours per year (1 average milking lasts less than 2 hours – with two milkings a day) should have services done after the passage of given time and over this limit – after performing given amount of work.

## **References**

- Kowalik W. 2006. Analiza charakteru zmian awaryjności dojarek bańkowych w aspekcie ich okresowej obsługi technicznej. *Inżynieria Rolnicza*, No. 5(80), pp. 341 – 348
- Rzeźnik C. 2002. *Podstawy obsługi technicznej maszyn rolniczych*. Wyd. AR, Poznań.
- Simariiev J.A. 1998. Soverschenstvovat planovo – predupreditelnuju systemu techniceskogo obsluzywania zyvodnovodceskoj techniki. *Mech. i Elektr. Sel. Choz.*, No. 1, pp. 11 – 14.
- Tomczyk W. 2004. Problemy decyzyjne w procesie eksploatacji maszyn i urządzeń rolniczych. *Journal of Research and Applications in Agricultural Engineering*, No. 1, pp. 50 – 52.
- Żółtowski B., Tylicki H. 1998. Metody wyznaczania terminu kolejnego diagnozowania. *Zagadnienia Eksploatacji Maszyn*, Vol. 4, pp. 689 – 701.

## **ASSESSMENT OF FARM SUSTAINABILITY LEVEL AS A FUNCTION OF THE AGRICULTURAL PRODUCTION PROFILE**

*Stanislaw Krasowicz*

*Institute of Soil Science and Plant Cultivation – State Research Institute, Pulawy, POLAND*

*e-mail: sk@iung.pulawy.pl*

**Keywords:** sustainable development, assessment, farm, profile of agricultural production

### **Introduction**

Regardless of the farms profile, they all should be focused on the rational use of the production factors such as land, labour and capital. The factors impact is, to a great extent, dependent on how well its owner can utilize the existing natural and economic-organizational conditions of production, i.e. efficiently manage the land (nature), labour and capital resources as well as adapt to the demands of the market economy and thus the existing economic realities.

The aim of the paper is to try to assess the sustainability level of the farms representing different profiles of agricultural production.

### **Material and methods**

The paper deals with the results of the studies run over the years 2003-2005 in the farms cooperating with the Institute of Soil Science and Plant Cultivation-State Research Institute (IUNG-PIB) in Pulawy and the Division of Agricultural and Forest Sciences of the Polish Academy of Sciences in Poznan.

During the studies, farms specialized in different areas of agricultural production were compared and analysed from the point of view of the possibilities for their sustainable development. Based on the averages of 3 years, the farms were evaluated using the methods applied by the IUNG-PIB. The analysis was limited just to some production profiles.

Except for the above-mentioned research results, the article also reports the findings from the studies carried out by other authors that have been already presented as scientific publications. In addition, statistical data of the Central Statistical Office (GUS) were the important source of information.

**It has been assumed that the farm sustainability level depends on its production profile.**

## **Results and discussion**

Farm groups of different production profiles were compared regarding the accomplishment of the rules of sustainable development. The analysis proved the following points.

- Farms specializing in milk production or swine fattening of the area of approximately 37 ha AL and livestock density of 1,4 – 1,5 LU/ha deemed to have met the economic criteria. However, they pose some threat to the environment, mainly due to high positive balance of nitrogen and phosphorus .
- Crop production farms of the area of approximately 100 ha located on better soils, where sugar beets, rape and corn for grain were cultivated apart from the cereals, turned to be economically effective. On the other hand, the income they generated on poorer soils was too low. The main ecological threats identified for this management system are: higher consumption of pesticides, positive balance of nitrogen and reduction of biodiversity (transformation of permanent grassland into arable land, and limited range of crops). Additionally, another problem is that agricultural employment is seriously limited. At the moment, once the direct payments have been introduced, the economic situation of the farms might considerably improve;
- Farms with mixed animal production (different animal species at the average density of approximately 0,8 LU/ha AL) seemed to be the closest to meet the majority of the criteria for sustainable development.

Changing economic conditions of the Polish agricultural management make the production profitability vary. Such a situation requires from the farmers to introduce frequent changes both in the organization and intensity (technology) of agricultural production. This is the economic force that can serve as a reliable indicator of the management of the specialized farms.

The impact of economic and organizational factors is clear in many areas of management and assessment of such farms. These are economic-organizational issues that determine the following: the level of agricultural income, economic force and farm efficiency, possibilities to adapt the farm to changing economic realities, production marketability, the role of the CAP payments as a form of support for farmers, interactions between technical, economic and ecological efficiency.

## **Review and conclusions**

The analysis focused on some economic-organizational conditions of managing agricultural farms representing different production profiles showed that under the conditions of the market economy, economic-

organizational issues have a great impact on various aspects of agricultural farm performance. However, their impact varies and depends on farm specialization, production volume, and also on the ability to develop economically-sensible relationships between the production factors. It was also found that the competence of the manager and his ability to adapt the farm to changing economic realities play a crucial role.

The increasing impact of the economic conditions should not lead to neglect ecological aspects of agricultural management and, even in a broader sense the general rules of sustainable agriculture. The considerations, to a great extent, have confirmed the hypothesis expressed at the beginning of the paper. Farm acreage seems to be of a relatively lower significance and there is an increasing importance of the economic vitality (force).

The methods used in the studies make it possible to carry out a simplified assessment of the sustainability level of the farms depending on the production profile but there is a need to improve the methods and include in the assessment some new indicators and criteria.

## **WAREHOUSING POTENTIAL AND ITS USE BY SPECIALISED FARMS**

*Maciej Kuboń*

*Agricultural University in Kraków, Department of Agricultural Engineering and Informatics,  
Kraków, POLAND*

*e-mail: kubon@ar.krakow.pl*

**Keywords:** logistics infrastructure, warehouse

### **Introduction**

The level of stock on farms depends on many internal and external factors. Agricultural activity, characterised by natural production process, requires adjustment of the rules of stock management to technological needs. The necessity to maintain stock is caused, first of all, by the need to assure continuity of production processes, continuity of sales, protection against changes of prices as well as maintenance of the quality of agricultural products produced by the farm. Nevertheless, stock increases storage costs and makes a given product unprofitable for some time. Therefore, the quantity of stock has to be justified economically. Maintenance of stock on the defined quantitative and qualitative level forces farmers to have the required warehousing infrastructure in the form of buildings and warehouse structures (barns, umbrella roofs, silos, cooling rooms, tanks and manure plates). The number and type of warehouses should result from the production profile and transport organisation (provisions and sales) while all activities connected with stock management should aim at minimising direct and indirect storage costs.

### **Aim, scope, methods of work**

The aim of the study was to define warehousing potential and its use on specialised farms. Analyses were carried out on 50 farms situated in the southern Poland with various types of production. The analysed farms were divided into the following groups:

Group A - farms which are specialised in land cultivation,

Group B - farms which are specialised in breeding animals with pasturing system,

Group C – farms which are specialised in breeding animals with concentrate fodder,

Group D – various crops and animals together,

Group E – farms which are specialised in gardening.



## Survey results

Table 1 presents the general group's characteristics. Group A (farms specialised in land cultivation) presents the biggest average area (107.8 ha), and Group E (farm specialised in gardening) the smallest (6.9 ha).

Table 1. Characteristics of surveyed farms

Farm group	Number of farms in the group units	Average farm size Ha	Distance from		Share of stored mass in the process		
			provisions market	sales market	provisions	production	distribution
			km		%		
A	10	107.8	94.8	172.1	63.9	97.7	86.3
B	10	17.6	3.6	35.5	76.3	91.0	31.4
C	8	20.5	13.7	9.4	70.4	96.5	48.9
D	10	9.5	7.1	10.2	49.0	95.1	33.2
E	12	6.9	9.1	29.1	60.8	-	13.3

Farms in group B were closest to the provisions markets (3.6 km) while farms in group A were furthest both from provisions and sales markets: 94.8 km and 172.1 km, respectively. Such big disproportion in distance between group A and the remaining groups results from the necessity to win more profitable provisions and sales markets. Legitimacy of having the required warehousing area on a farm was justified in the percentage of product mass which is stored on a farm in the processes of provision, production and distribution. In provisions over 70% of purchased production means in group B and C is stored while in groups A and D it is over 60%. In the production process over 90% of produced goods destined, within internal consumption on the farm, to be used in the same or other branch of production is stored. In distribution the most products were stored in group A (86.3%) and the least in group E: 13.3%.

Table 2 presents warehousing potential of the analysed farms. Warehousing potential is presented as a sum of warehousing areas located in buildings for animals, warehouses and storage rooms, garages, umbrella roofs and silos.

Table 2. Storage potential of analysed farms

Farm group	buildings for animals	warehouses and storage rooms	garages & umbrella roofs	Silos	Total	
					m <sup>2</sup>	m <sup>3</sup>
A	29.4	410.2	696.8	267.1	11.7	77.9
B	175.8	168.6	144.8	5.4	29.1	109.3
C	306.9	187.5	95.2	9.0	28.8	117.5
D	111.2	160.3	141.6	-	49.3	195.3
E	-	69.1	133.5	-	43.3	156.7

Relation of the storage area to 1 ha of land cultivation is the indicator which allows to compare storage area of buildings and structures. Farms in groups D and A have the biggest warehousing potential: 49.3 m<sup>2</sup>·ha<sup>-1</sup> and 43,3 m<sup>2</sup>·ha<sup>-1</sup>, respectively; farms from group A have the smallest: 11.7 m<sup>2</sup>·ha<sup>-1</sup>. Similar relations are in terms of m<sup>3</sup>·ha<sup>-1</sup>. The biggest warehousing area located in buildings for animals had farms from group C: 306.9 m<sup>2</sup>, whereas in other cases (warehouses and storage rooms, garages, umbrella roofs and silos) from group A.

The use of warehousing area in percentages is presented in table 3. Every listed element of warehousing infrastructure served for storage of means of production (SP), agricultural products (PR) and agricultural equipment (MA).

Table 3. The use of storage area [%]

Farm group	buildings for animals			Warehouses and storage rooms			Garages and umbrella roofs			Grain silos
	SP	PR	MA	SP	PR	MA	SP	PR	MA	PR
A	3.6	4.1	-	25.8	50.2	11.7	3.8	6.2	77.0	95
B	3.1	4.5	-	46.1	25.1	-	9.9	27.0	63.1	79
C	22.5	6.9	-	22.8	57.2	-	5.6	6.2	72.5	88
D	-	27.0	-	24.2	63.2	-	4.0	2.0	90.0	-
E	-	-	-	8.2	8.2	10.2	18.6	-	45.8	-

In buildings for animals the biggest area was occupied by agricultural products (27%) in group D and means of production (22.5%) in group C. In farms of A, C and D groups, over 50% of warehousing area located in warehouses and storage rooms was occupied by agricultural products. Means of production occupied from 8.2 to 46.1% of warehousing area and machines – 10.2% in group E and 11.7% in group A. In garages and under umbrella roofs were stored mostly machines and agricultural equipment (45.8-90%). Only A, B and C farms had grain silos and their average use during the year was 79-95%.

Table 4 presents the structure of use of storage potential. In general, in the analysed groups of farms average annual use of warehousing area was within the limit of 63.6-88.6%, whereas the biggest use was on farms which are specialised in land cultivation and the lowest on farms with animal breeding in pasturing system.

Table 4. Structure of use of storage potential [%]

Farm group	Production means	Agricultural produce	Agricultural machines and equipment	Total
A	11.6	34.2	42.8	88.6
B	26.6	17.9	20.8	65.3
C	23.3	29.9	19.4	72.6
D	9.7	36.7	33.0	79.4
E	20.0	6.0	37.6	63.6

The analyses indicate that the biggest part of storage area was occupied by agricultural machines and equipment (19.4-42.8%), which on most farms were stored in garages and under umbrella roofs as well as in warehouses adapted to store machines. Agricultural products covered from 6 to 34.2% of total storage area on farms while means of production accounted for 9 to 26.6%.

## **Conclusions**

1. Warehousing potential in the analysed groups of farms ranked from 11.7 (group A) to 49.3 m<sup>2</sup>·ha<sup>-1</sup> (group D). For group A, 49.6% of warehousing area was made up of garages and umbrella roofs, 29.2% were warehouses and storage rooms and the remaining 21.2% were building for animals and silos. For group D, warehouses and storage rooms made up 38.8% of total storage area, garages and umbrella roofs: 34.3% and 23.9% the area of buildings for animals.
2. In the analysed groups of farms, warehousing potential was used from 63.6% in group E to 88.6% in group A. Silos, warehouses and storage rooms were most used elements of infrastructure while buildings for animals were least used.
3. Agricultural machines and equipment occupied the biggest part of warehousing area: 33.8%, while production means occupied the smallest area – 18.2%.

## GROUND STRESS MODELING

*Aleksander Vasil'evich Kuzmitski, Georgiy Filippovich Betenja*  
*Belarusian State Agrarian Technical University, Minsk, BELARUS*  
*e-mail: zmiter@nm.ru*

**Keywords:** soil, deformation, stress field, stress gradient, stress function.

The problem of quantitative estimation of static tensions in case of applying concentrated load to soil body was first formulated and solved by Z. Bussinek [2].

Specifically, he has obtained the equation establishing dependence of radial stresses  $\sigma_R$  on the value of applied force  $F$ , distance  $R$  to the load application point and the angle  $\beta$  of deflection from the force direction.

$$\sigma_R = \frac{3}{2} \cdot \frac{F}{\pi \cdot R^2} \cos \beta. \quad (1)$$

Equation (1) shows that radial stresses are inversely proportional to the squared distance to the load  $F$  application point and directly proportional to the cosine of the angle of deflection from the direction of this force. Curve of radial stresses according to equation (1) is shown on the figure 1. As it can be seen on the figure the curve is crescent, changing from 0 at  $Y$ -axis to maximum (amplitude) at  $X$ -axis.

Transactions by V.P. Goryachkin, V.A. Zheligovsky, M.E. Matsepuro, A.T. Vagin, Y.V. Chigarev and others include rich scientific, theoretical and practical material in this area.

Let us inscribe circle of radius  $R/2$  in the semicircle  $R$  (fig. 1) and choose two arbitrary directions  $l_1$  and  $l_2$  at angles  $\beta_1$  and  $\beta_2$  to  $X$ -axis accordingly. Rays  $l_1$  and  $l_2$  cross semicircle  $R$  in points  $M$  and  $N$  and inscribed circle in points  $M_1$  and  $N_1$ . We will draw semicircles of radius  $R_1$  and  $R_2$  from the centre  $O$  through obtained points  $M_1$  and  $N_1$ .

Let us define radial stresses on obtained scheme in the direction  $l_1$ . According to Bussinek's formula the radial stress  $\sigma_{RM}$  in the point  $M$  will be:

$$\sigma_{RM} = 3F \cos \beta_1 / (2\pi R^2) \text{ and in the point } M_1:$$

$$\sigma_{RM_1} = 3F \cos \beta_1 / (2\pi R_1^2).$$

Radiuses  $R_1$  and  $R$  are bound with simple proportion from  $\triangle OM_1A$ :  $R_1 / R = \cos \beta_1$  or  $R_1 = R \cos \beta_1$ . Then

$$\sigma_{RM_1} = 3F / (2\pi R^2 \cos \beta_1) \quad (2)$$

and because of equality of corresponding angles (see fig. 1) the projection  $\sigma_{M1}$  of this stress on the normal to the inscribed circle is

$$\sigma_{M1} = 3F / (2\pi R^2) = \sigma_{RA}, \quad (3)$$

where,  $\sigma_{RA}$  is radial stress in the point A (with  $\cos \beta = 1$ ).  
In the direction  $l_2$ , similarly to discussed above:

$$\sigma_{RN1} = 3F \cos \beta_2 / (2\pi R_2^2),$$

and as  $R_2 = R \cos \beta_2$ , then

$$\sigma_{RN1} = 3F / (2\pi R^2 \cos \beta_2), \quad (4)$$

and the concerning projection of this stress on the normal to inscribed circle

$$\sigma_{N1} = 3F / (2\pi R^2) = \sigma_{RA}. \quad (5)$$

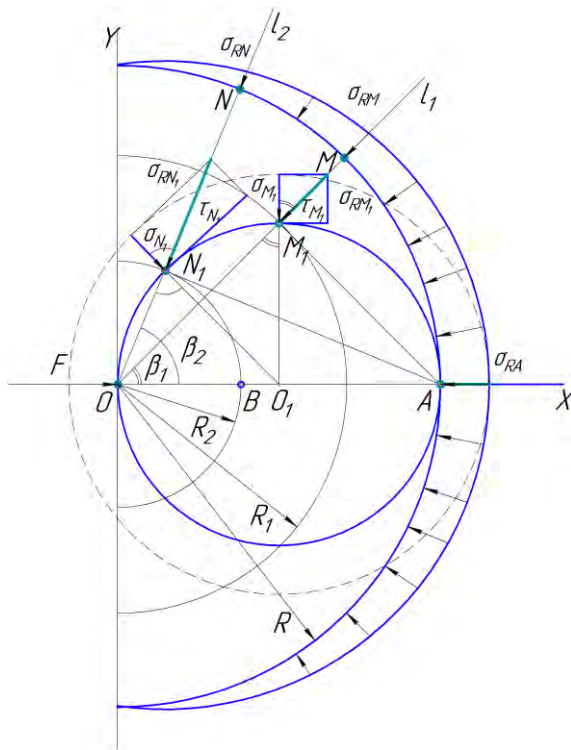

Figure 1. Scheme to the analysis of stress field of point source

As we can see, at any direction  $l$  normal components of radial stress to inscribed circle are equal inter se and equal to radial stress at  $X$ -axis in the point  $A$ , i.e. curve of normal stresses  $\sigma$  for inscribed circle shapes into circle (see fig. 1). Thus, there is the circle being formed (in the space it is spherical domain with a diameter  $D=R$ ) in the soil body in front of the point of force  $F$  application that is compressed by normal stresses, value of which is directly proportional to force  $F$  and inversely proportional to squared diameter or sphere  $D$  surface area

$$\sigma = 3F / (2\pi D^2) \quad (6)$$

Circle diameter decreases with the increase in force  $F$  and stress at the point  $O$ . From the static point of view this area is a self-balanced system that is theoretically impossible to destruct: at any value of the force  $F$  the sphere collapses but remaining in balance.

Let us estimate values of shearing stresses on the circle  $D$  in the point  $M_1$ . Considering equality of corresponding angles  $\tau_{M_1} = \sigma_{RM_1} \cdot \sin\beta_1$  or, putting value  $\sigma_{RM_1}$  from expression (2) we will obtain:

$$\tau_{M_1} = 3F \operatorname{tg}\beta_1 / (2\pi R^2). \quad (7)$$

In the point  $N_1$  shearing stresses will be

$$\tau_{N_1} = 3F \operatorname{tg}\beta_2 / (2\pi R^2), \quad (8)$$

and in general, with consideration of expression (6), the change of shearing stresses on the circle  $D$  will be defined by expression

$$\tau = \sigma \cdot \operatorname{tg}\beta. \quad (9)$$

Therefore, shearing stresses along the circle change from zero on the force direction ( $X$ -axis) to infinity on the direction that is perpendicular to force  $F$  ( $Y$ -axis). Hence, nearby point  $O$ , because of considerable shearing stresses the conditions are created for the destruction of deformer of any hardness. In practice sharp-ground ploughshare or chisel is growing blunt actively just in the initial period of work until blade becomes so blunt that effect of above mentioned shearing stresses shifts in the zone of soil that sticks on it, i.e. in area  $D$  itself. At this moment blunting rate decreases and for some time the working element parameters maintain relatively stable values (period of normal service).

When analysing stressed area we note one more property of stresses that are radial to point  $O$ : their projection on  $X$ -axis is constant and is equal to normal stresses  $\sigma = \sigma_{RA}$ . In fact, considering expressions (2), (4)

$$\sigma_x = \sigma_{RM1} \cdot \cos\beta_1 = \sigma_{RN1} \cdot \cos\beta_2 = \sigma = 3F / (2\pi D^2). \quad (10)$$

Circle D is displaced in relation to zero point for amount of  $2a = D$ . Equation of this circle takes form

$$x^2 + y^2 = 2ax, \quad (11)$$

from which

$$y = \sqrt{2ax - x^2} \text{ or } f(x) = \sqrt{2ax - x^2}. \quad (12)$$

In the polar coordinates for  $x = \rho \cos\beta$  we obtain

$$f(x) = \pm \sqrt{2a\rho \cos\beta - \rho^2 \cos^2\beta}. \quad (13)$$

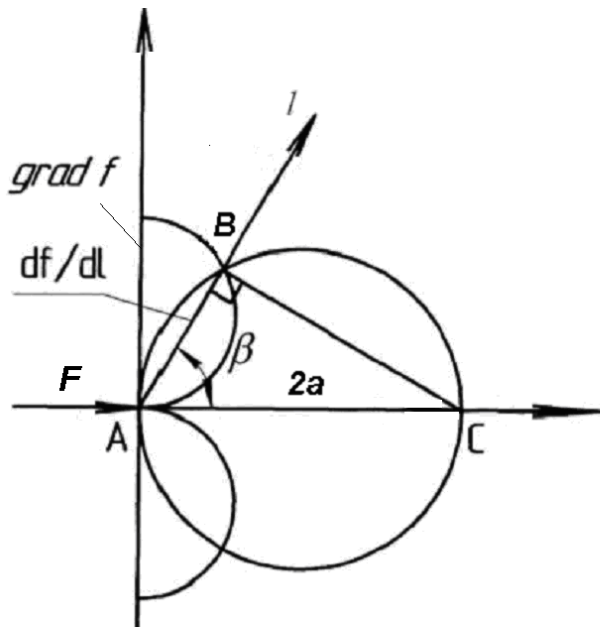

Figure 2. Directional derivative and gradient of a function of shearing stresses

From  $\triangle ABC$  (fig. 2)  $2a = \frac{\rho}{\cos \beta} \Rightarrow \rho = 2a \cos \beta$ . After inserting value  $\rho$  in the formula (13) we'll obtain

$$f(x) = \pm \sqrt{\rho^2 - \rho^2 \cos^2 \beta} = \pm \rho \cdot \sin \beta. \quad (14)$$

It is known that derivative  $\frac{df}{dl}$  of function  $f(X)$  in point  $A$  in the direction  $l$  is a limit in point  $A$  of ratio of the function increment on  $l$  to the distance  $\rho(A, X)$

$$\frac{df}{dl} = \lim \frac{f(X) - f(A)}{\rho(A, X)}. \quad (15)$$

In our case the directional derivative takes form

$$\frac{df}{dl} = \lim \frac{f(\rho \cos \beta, \rho \sin \beta)}{\rho} = \lim \left( \pm \frac{\rho \sin \beta}{\rho} \right) = \pm \sin \beta. \quad (16)$$

The  $\pm$  sign in the expression (16) defines position of sine curve branches in 1 and 4 quadrants  $XOY$  (fig. 2).

Physical meaning of directional derivative is that it shows the rate of change in values of stress function in the direction of said vector  $l$  and the function  $f$  gradient is a vector showing the direction in which this rate of change is the maximum.

Function  $f$  gradient in point  $A$  is defined as a vector the projections of which on coordinate axes are equal to corresponding derivatives of function  $f(X)$  in point  $A$ . It is also known that directional derivative  $\frac{df}{dl}$  is a scalar product of gradient and unit vector of direction  $l$ . Therefore, the derivative in the direction  $l$  is equal to projection of gradient on this direction:

$$\frac{df}{dl} = \text{grad}f \cdot l = |\text{grad}f| \cdot \cos(90 - \beta) = |\text{grad}f| \cdot \sin \beta. \quad (17)$$

Considering formula (16) we obtain:

$$|\text{grad}f| \cdot \sin \beta = \pm \sin \beta, \quad (18)$$



from which

$$\text{grad}f = \pm 1. \quad (19)$$

As we can see, the directional derivative is a harmonic continuous function. It defines running values of parameters participating in the energy-transfer process. And the gradient is a constant value not depending on parameters of stress circle.

## **BIBLIOGRAPHY**

1. Chigarev Y.V. 2004. Mathematical background of soil mechanics: Educational guidance / Y.V. Chigarev, P.N. Sinkevich. – Mn.: UE «Technoprint». 164 p.
2. Farrell D.A., Greacen E.L., Larson W.E. 1967. The effect of water content on axial strain in a loam under tension and compression. *Soil Sci Soc Am Proc* 31: 445-450.
3. Goryachkin V.P. 1968. Collected works. In 3 volumes. 2<sup>nd</sup> edition, v. 2, M., «Kolos». 455 p.
4. Vagin A.T. 1965. Revisited matter of interaction of wedge with soil. Background for basic parameters of aggregates for soil fertilizing layer by layer. – In the book: *Agricultural mechanics issues*. V. 15. Minsk, Gosizdat BSSR, pp. 4–142.
5. Zheligovsky V.A. 1960. Elements of theory of cultivating machines and mechanical technology of agricultural materials. *Works of Georgia Agricultural Institute*. Tbilisi. 145 p.

## **EFFECTIVENESS OF MECHANISATION ENERGY WILLOW CULTIVATION**

*Dariusz Kwaśniewski*

*Agricultural University in Kraków, Department of Agricultural Engineering and Informatics,  
Kraków, POLAND*

*e-mail: kwasniew@ar.krakow.pl*

**Keywords:** energy willow, work outlays, costs, effectiveness

### **Introduction**

Soil for cultivation of energy willow should be well prepared for planting like for other agricultural crops and weeded out very well in order to provide correct growth and development of plants in the first years of cultivation. Mechanisation of field preparation process for cultivation does not pose a problem. Literature provides information on cultivation technologies, e.g. (Szcukowski et al 2004, Dubas et al 2004). However, effectiveness of mechanisation of willow cultivation in Polish reality is lowered because of lack of technical solutions related to the process of willow collection. On many plantations this activity is manual in combination with solutions (e.g. chain saws, mechanical scythes) which decisively decrease effectiveness of mechanisation.

### **Aim, scope and methods of analysis**

The aim of the study was to determine and assess effectiveness of mechanisation of cultivation of energy willow based on chosen plantations from southern Poland. This assessment was related to the 1<sup>st</sup> year of cultivation when collected shoots are most often used for willow saplings. Analyses covered 27 chosen energy willow plantations situated in provinces: Małopolskie, Świętokrzyskie and Podkarpackie. On the basis of an interview with the owner of a plantation it was determined which activities were performed on it. Technical cards of cultivation allowed us to determine work outlays borne.

Effectiveness of mechanisation was determined by indicators expressed in PLN/t of willow dry mass after 1 year of cultivation and in PLN/GJ. Following the literature (Szcukowski et al 2004, Dubas et al 2004), it was assumed that water content in willow shoots at the moment of harvesting is on average 50%. Calorific value at the moment of willow collection was assumed as 8.8 GJ/t (Grzybek, Gradziuk, Kowalczyk 2001).

## Analysis results

The analysed plantations of energy willow were divided into three groups:

- group I (9 plantations): willow cultivation are not exceeding 1 ha,
- group II (8 plantations): area within the limits 1.1 to 5 ha.
- group III (10 plantations): area exceeded 5 ha.

Work outlays in year 1 of energy willow cultivation (with division into activities performed manually and with by machines) are presented in table 1.

Table 1. Work outlays in year I of energy willow cultivation

Group	Parameter	Willow area	I year of cultivation		
			Total outlays	Manual work	Machine work
group I	<b>average</b>	<b>0.49</b>	<b>375.4</b>	<b>303.8</b>	<b>71.6</b>
	standard deviation	0.24	220.6	163.5	67.4
group II	<b>average</b>	<b>3.11</b>	<b>358.3</b>	<b>273.9</b>	<b>84.4</b>
	standard deviation	1.38	174.5	157.7	35.3
group III	<b>average</b>	<b>13.01</b>	<b>303.1</b>	<b>228.3</b>	<b>74.8</b>
	standard deviation	9.29	93.3	76.5	34.5
total	<b>average</b>	<b>5.90</b>	<b>343.6</b>	<b>267.0</b>	<b>76.6</b>
	standard deviation	7.90	165.0	134.2	46.6

It should be emphasised that labour outlays were high and on average, for 27 analysed plantations, were 343.6 working hours/ha (267 working hours/ha were labour outlays related to manual work). The highest labour consumption - 375.4 working hours/ha - was in group I, while the lowest was on plantations in group III (303.1 working hours/ha on average). In group I most works after 1<sup>st</sup> year of cultivation were done manually, especially planting, weeding out and harvesting, with use of secateurs and pruning shears. On bigger plantations (group II and in particular group III) harvesting was done with sickle mowers with shortened bar and mechanical sickles with a plate. Labour consumption of such method of harvesting was high because after cutting (manual as in group I) bundles were made and shoots were bound together after being cut. Apart from that, manual activities included planting, weeding out, spraying of some plantations against weeds and protection against wild animals (boars, roe deer) with use of, for example, *STOP Z* (plantations in group III).

Mechanisation costs for year I of energy willow cultivation with division into fixed costs, current costs (with labour costs separated) and costs of purchased mechanical services are presented in table 2. These costs were on average 3471.0 PLN/ha.

Table 2. Mechanisation costs in the 1st year of energy willow cultivation

Group	Parameter	Willow cultivation area	Mechanisation costs (PLN/ha)				
			fixed costs	current costs		Costs of purchased services	total costs
				total	incl. labour		
Group I	<b>average</b>	<b>0.49</b>	<b>875.4</b>	<b>2665.7</b>	<b>1276.5</b>	<b>424.7</b>	<b>3965.8</b>
	standard deviation	0.24	674.1	1889.1	766.0	474.9	2303.5
Group II	<b>average</b>	<b>3.11</b>	<b>492.8</b>	<b>1737.7</b>	<b>680.4</b>	<b>1051.4</b>	<b>3281.9</b>
	standard deviation	1.38	312.1	996.9	389.9	717.0	1574.5
Group III	<b>average</b>	<b>13.01</b>	<b>391.1</b>	<b>1662.7</b>	<b>620.8</b>	<b>1123.1</b>	<b>3176.9</b>
	standard deviation	9.29	270.9	838.5	323.2	1144.9	776.4
total	<b>average</b>	<b>5.90</b>	<b>582.7</b>	<b>2019.2</b>	<b>857.0</b>	<b>869.1</b>	<b>3471.0</b>
	standard deviation	7.90	487.5	1351.7	591.3	874.6	1624.1

The level of fixed costs in particular groups of plantations was definitely lower than the level of current costs. The highest fixed costs were characteristic for group I and were 875.4 PLN/ha, and the lowest were in group III (391.1 PLN/ha). On the other hand, current costs were 2665.7 PLN/ha and 1662.7 PLN/ha respectively for group I and III. In group III where willow plantations had the biggest area (13.01 ha on average) work efficiency with use of machines and tools was bigger. Higher work efficiency means smaller fuel and lubricant costs which in effect causes smaller current costs.

Group I obtained the smallest yield of fresh biomass after 1. It was on average 6.8 t/ha of fresh biomass (3.4 t/ha of dry biomass). Plantations in group II had the biggest productivity. Their yield was on average 9.4 t/ha of fresh energy willow. Fresh biomass yield for all plantations in general was 7.9 t/ha.

Table 3. Effectiveness of mechanisation on analysed plantations

Group	Parameter	Effectiveness of mechanisation	
		(PLN/t)	(PLN/GJ)
Group I	<b>average</b>	<b>1283.4</b>	<b>145.8</b>
	standard deviation	890.7	101.2
Group II	<b>average</b>	<b>721.3</b>	<b>82.0</b>
	standard deviation	341.8	38.8
Group III	<b>average</b>	<b>911.0</b>	<b>103.5</b>
	standard deviation	314.0	35.7
Total	<b>average</b>	<b>978.9</b>	<b>111.2</b>
	standard deviation	603.3	68.6

Effectiveness of mechanisation of cultivation on analysed willow plantations (table 3) was 978.9 PLN/t of dry mass and in calculation into energetic value

it was 111.2 PLN/GJ. Willow yield was low in the year I of cultivation (nevertheless, comparable with data found in literature on the subject). This had a considerable impact on obtained results related to mechanisation effectiveness.

## Conclusions

1. Cultivation of energetic willow, especially in 1<sup>st</sup> year, requires big work outlays (especially when planting it manually). On average, these outlays were 343.6 working hours/ha. Among analysed plantations, the biggest work outlays for manual work were in group I and equalled 303.8 working hours/ha. Outlays connected with mechanised work were lowest in this group (71.6 working hours/ha).
2. Mechanisation costs for willow cultivation in year I were in total 3471.0 PLN/ha. Fixed costs equalled 582.7 PLN/ha and current costs 2019.2 PLN/ha. Current costs (including labour costs) had decisive impact on the level of mechanisation costs. Labour costs were highest in group I, where they equalled 1276.5 PLN/ha and the lowest on plantations in group III (620.8 PLN/ha).
3. Effectiveness of mechanisation on analysed plantations expressed in PLN/t and in PLN/GJ was quite different regarding the area group. Group II showed highest degree of mechanisation effectiveness with 721.3 PLN/t of dry biomass (82 PLN/GJ). On the other hand, the lowest effectiveness had plantations with area up to 1 ha from group I (1283.4 PLN/t – 145.8 PLN/GJ). For 27 plantations in the 1<sup>st</sup> year of cultivation the indicator of mechanisation effectiveness was 978.9 PLN/t (111.2 PLN/GJ).
4. Low mechanisation effectiveness on analysed plantations was mainly caused by the fact that in many cases activities related to willow planting, weeding out, harvesting after the 1<sup>st</sup> year, were done manually. The fact that some activities were repeated twice or even three times had also contributed to that. In effect, labour outlays were high and, in result, mechanisation costs were higher.

## References

- Dubas J. W., Grzybek A., Kotowski W., Tomczyk A. 2004. *Wierzba energetyczna - uprawa i technologie przetwarzania*. (Energy willow: cultivation and processing technologies) Editor: Wyższa Szkoła Ekonomii i Administracji w Bytomiu
- Grzybek A., Gradziuk P., Kowalczyk K. 2001. *Słoma energetyczne paliwo*. (Straw energy fuel) Warszawa
- Szczukowski S., Tworkowski J., Stolarski M. 2004. *Wierzba energetyczna*. (Energy willow) Kraków

## **ORGANIZATION OF MECHANIZATION IN SELECTED FAMILY FARMS**

*Edmund Lorencowicz<sup>1</sup>, Jacek Uziak<sup>2</sup>*

*<sup>1</sup>Agricultural University in Lublin, Department of Machinery Exploitation and Management  
in Agricultural Engineering, Lublin, POLAND*

*e-mail: edmund.lorencowicz@ar.lublin.pl*

*<sup>2</sup> University of Botswana, Department of Mechanical Engineering, Gaborone, BOTSWANA*

*e-mail: uziak@mopipi.ub.bw*

**Keywords:** family farms, mechanization, farm mechanization management

### **Introduction**

Family-run farms constitute the greatest part of agricultural farms in Poland. By legal definition, a family farm is run by the individual farmer, and his Utilized Agricultural Area (UAA) does not exceed 300 ha. One noteworthy characteristic of Polish agriculture is the fact that the average farm area is relatively low (7.41 ha in 2002), and less than one percent of farms are larger than 50 ha.

In the Lublin province, where this study was carried out, the farm size structure is even more unfavourable. The average farm size is 6.57 ha and only 0.3% of farms have a total area above 50ha (Table 1). It is estimated that 57% of these farms produce goods mainly for their own consumption.

Table 1. Farms structure in Poland and Lublin region (2002)

Farm Size	Poland			Lublin Province		
	Contribution in Area [%]	Contribution in Number of Farms [%]	Average Area [ha]	Contribution in Area [%]	Contribution in Number of Farms [%]	Average Area [ha]
1.01-5.0 ha	19,1	58,7	2,41	21,6	54,2	2,62
5.01-10.0 ha	20,9	21,9	7,10	30,9	29,7	7,08
10.01-50.0 ha	43,9	18,6	17,58	41,2	16,8	16,12
above 50 ha	16,0	0,9	135,07	6,3	0,3	124,81

Source: Report on the Agricultural Census 2002. Central Statistical Office, Poland

### **Research methodology and characteristics of the research objects**

At the beginning of 2007, a questionnaire-based survey of 114 selected farms in the Lublin province was carried out. The aim of this study was to gauge the degree of mechanization and the organization of mechanized labour as well as the changes in farmer's equipments. The farms were characterised by diverse areas and structures (Table 2).

Table 2. General characteristics of selected farms

Specification	Unit	Value
Average UAA	ha	13.66
Share of major crops:		
- corn	%	66.0
- oilseed rape	%	3.0
- potatoes	%	2.7
- sugar beet	%	2.7
- meadows & pastures	%	15.8
Labour Force	person/farm	3.6

The average size of arable land is 13.66 ha, with a minimum of 2.17 ha and a maximum of 144.85 ha for crop production (variation coefficient - 136.7%). 62 farms were leasing the land and the maximum area of leased farmland was even as many as 130 ha. The average area of the leased land in relation to the total UAA was 32.3%.

In the studied sample, only 10.5% (12 farms) plan to increase their agricultural area, as well by leasing as by purchasing. These farms have an average area of 28.45 ha, and only three have less than 10 ha. The remaining farms don't plan to expand.

The farms in the studied sample are abundant with labour force. It has been revealed that 412 labourers work on the 114 studied farms (of which some were casual or part-time workers). The average age of the farm's owner was 45.1 years; the oldest was 61 whilst the youngest 20. Apart from the owners, there are 298 workers employed on the farms, i.e. 2.6 per person per farm. As many as 54 workers also have other jobs ranging from 25 to 2300 hours per year, 33 of whom were employed on a full time basis. In most cases this has been a co-owner of the farm or his adult children.

The degree of mechanization and the technical resources of the farms vary. Every farm in the survey owned at least one tractor as well as a set of tools intended for soil cultivation such as plough, harrow, cultivator (Table 3). In fact, also the sowing and spraying could have been done using own equipment. Though, the situation was dire when looking at the group of remaining machinery, mainly for harvesting. The only way to carry out farm work using new technology is to develop various types of collaboration.

Table 3. Ownership of basic machinery

Specification	Total Number	Per Farm	Average Age of Machinery [Year]
Tractors	142	1,25	21,2
Manure spreaders	82	0,72	19,4
Fertilizer spreaders	94	0,82	15,1
Seed drills	111	0,97	17,2
Sprayers	149	1,30	11,9
Mowers	86	0,75	13,5
Combine harvesters	30	0,26	24,8

### Forms and principles regarding the organization of mechanization

In the studied sample of farms, a number of methods of mechanization were used which enabled a reduction in investment expenditure on fixed assets. The farmers made use of 48 co-owned equipments, including ones as complex as tractors and self-propelled grain combine harvesters.

In most cases these machines were jointly owned by two parties; mostly by relatives. The use of contract work and renting (without service) of machinery was also common (later referred to as machine imports).

Out of 267 instances where machinery was brought externally for use on the farm (import), 64% were contract work, and in 36% of cases the machinery was rented. Out of 204 instances where the farmers' own machinery was used externally (export), 43% of the time these were contract work while in 57% of cases, the machinery was leased out. The most commonly exported pieces of equipment were grain combine harvesters, forage collecting machines and plant protection and cultivation machines (Table 4).

Table 4. Import and export of machines

Specification	Import		Export	
	Renting	Contract Work	Renting	Contract Work
Tractors	1	0	7	2
Cultivating equipment	4	2	5	3
Fertilizing equipment	13	3	10	0
Planters (grain drills and crop planters)	22	7	17	5
Plant protection and crop maintenance equipment (sprayers, ridgers)	11	16	10	9
Combine harvesters	3	73	4	16
Potato machines (potato harvesters and potato diggers)	7	6	6	11
Sugar-beet machines (sugar-beet harvesters and beet diggers)	0	3	0	1
Forage harvesting equipment (balers, mowers, hay makers)	14	45	22	21
Trailers	6	1	13	3



The farmers settled accounts amongst themselves in a variety of ways. Most often this was done in monetary terms (Figure 1a). The payment was also done by exchanging equipments – 16%. In 16% of cases farmers paid back their dues by lending their labour and/or machinery, whilst in 7% of cases the farm-owners reported a lack of payments or settlement of accounts. The method of settling accounts for the farms - import was similar to that of machinery brought externally (Fig. 1b). In 58% of cases the settlement was done by cash repayment, 26% of the time the debt was repaid by lending labour or equipment, in 6% of cases it entailed an exchange of pieces of machinery whereas 10% of the time the debt was not settled.

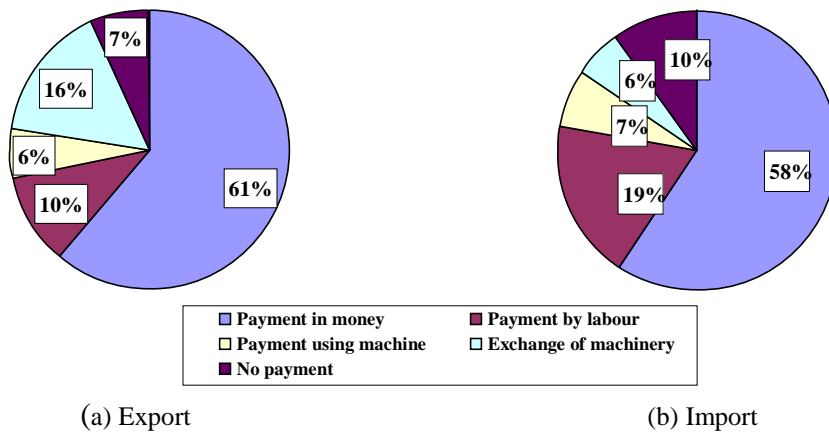

Figure 1. Structure of settling accounts for import and export of machinery

The majority of cases involving a cash-based method of settling accounts were done (both exports and imports) with the use of machines such as self-propelled grain combine harvesters, balers and sprayers.

### Summary

The above results show a stable level of cooperation amongst farmers. There is a considerable number of machinery pools and collaboration by means of machinery ring cooperatives (contractors). Economic changes have narrowed the range of these activities, whilst at the same time have widened the service-providing activity of the farmers, which supplement the work potential of self-owned equipment. It is expected that, following the example of other European countries, a commercialization of services together with the possible development of machinery rings is the mostly likely scenario.

## **TECHNICAL EQUIPPING INDICATOR AND WORK EFFICIENCY IN RELATION TO SIMPLIFICATION OF PLANT PRODUCTION**

*Urszula Malaga-Toboła*

*Agricultural University in Kraków, Department of Agricultural Engineering and Informatics,  
Kraków, POLAND*

*e-mail: malaga@tier.ar.krakow.pl*

**Keywords:** technical equipping, technical equipping indicator, work outlays, pure production, work efficiency, production direction, simplification

### **Introduction**

Work efficiency and capital intensity of production are two values which result from the relation between outlays and production and which describe the technology of production of particular goods. Capital intensity characterizes production technology through material outlays and with its increase there is an increase of work efficiency. The output production value, which depends on a combination of capital outlays and work, has an important influence on work efficiency.

### **Aim, scope and methods of work**

The aim of the study was to determine the dependency between the technical equipping indicator and work effectiveness on farms with various production type and level of simplification. The study covered 116 investment applications submitted by farmers in Małopolska region to the Agency for Restructuring and Modernisation of Agriculture to obtain financing for investment. In order to carry out a comparative analysis the analysed farms were divided into three main groups, that is, with plant, animal and mixed production. Farms with plant production were divided into vegetable, orchard and general plant producers. Animal farms were divided into subgroups being specialised in cattle, pig and sheep breeding. Moreover, the farms analysed in 2002 were divided into 7 and in 2007 into 8 groups depending on the number of technologically homogenous plant groups cultivated by them. The number of technically homogenous groups determines the level of simplification. The highest, 1<sup>st</sup> grade of simplification covers only one group of plants. Next simplification levels correspond to an increasing number of plant groups.

### **Characteristics of analysed farms**

Among the differentiated groups, animal production farms tended to have highest degree of simplification. High degree of simplification of production on pig and sheep farms has a decisive influence on it. On farms with plant production, vegetable and general plant farms had multi-branch

activity. Farms with mixed production profile had most differentiated plant production. The changes introduced in plant production structure shall have a negative impact on the degree of its simplification on farms with plant production and on two-way farms. On the other hand, animal production farms shall have further tendency to simplify production.

### **Results of analyses**

A systematic modernisation of national agriculture is necessary to improve effectiveness of agricultural production. This is not possible without scientific and technological progress which, according to the methodology developed by Michałek and Kowalski [1998], is the difference between indicators of technical equipping of farms in a given time limit. Measurable effects of progress shall include, among others, an increase of work effectiveness. Orchard farms and pig breeding farms confirm this hypothesis, as during the analysed period (2002-2007) technical equipping indicator increased on most of them by 3.3 and 7.1%, respectively (tab. 1). At the same time, these farms recorded highest increase of work effectiveness, by 63.5 and 45.5% respectively (tab.2). Among groups of farms distinguished because of the degree of simplification of plant production in 2002, farms which cultivated two and four groups of technologically similar plants had the highest work effectiveness equal to 11.80 and 12.93 PLN/working hour

This result was influenced by the highest value of pure production recorded in these two groups, at the level 8.37 and 4.99 thousand PLN/ha of agricultural land. Also the level technical equipping was the highest on those farms and equalled: 107.88 and 114.87 PLN/working hour on farms with II and IV degree of plant production simplification respectively. During 5 analysed years, definitely the highest, almost triple increase of work efficiency was on farms with lowest VII level of production simplification. Also in this group the increase of technical equipping and pure production indicator was very high: 80.4 and 85.8%, respectively.

Table 1. Indicator of technical equipping according to production simplification level [PLN/working hour]

Simplification degree	farms										
	total	one way								two-way	
		plant production				animal production				mixed production	
		total	including			total	including				
vegetable	orchards		general plant	cattle	pigs		sheep				
<b>2002</b>											
<b>I</b>	23.41	37.65	37.65	-	-	16.30	-	16.73	15.86	-	
<b>II</b>	107.88	82.68	59.10	92.00	104.08	61.41	-	61.41	-	190.55	
<b>III</b>	98.87	93.67	89.87	53.66	114.12	161.39	184.70	138.07	-	57.17	
<b>IV</b>	114.87	111.26	80.44	78.47	176.99	112.74	113.86	112.18	-	134.25	
<b>V</b>	98.04	108.48	107.29	49.30	131.57	78.04	106.28	63.92	-	69.35	
<b>VI</b>	79.70	69.51	47.33	-	87.25	-	-	-	-	125.59	
<b>VII</b>	97.54	53.03	78.76	-	27.31	-	-	-	-	84.63	
<b>VIII</b>	-	-	-	-	-	-	-	-	-	-	
<b>total</b>	<b>99.42</b>	<b>97.94</b>	<b>86.46</b>	<b>72.39</b>	<b>128.21</b>	<b>89.92</b>	<b>134.95</b>	<b>81.20</b>	<b>15.86</b>	<b>111.65</b>	
<b>2007</b>											
<b>I</b>	66.03	84.28	-	84.28	-	29.52	-	-	29.52	-	
<b>II</b>	75.69	76.73	97.87	70.98	9.42	67.41	-	67.41	-	-	
<b>III</b>	86.15	87.79	79.36	-	125.70	121.13	184.55	89.43	-	177.52	
<b>IV</b>	95.09	82.09	85.40	81.34	87.78	119.77	140.84	98.69	-	97.57	
<b>V</b>	107.12	114.63	105.84	60.53	134.97	101.32	-	101.32	-	67.36	
<b>VI</b>	91.41	75.97	68.70	-	89.06	86.01	110.87	61.14	-	129.24	
<b>VII</b>	114.68	114.68	77.26	-	133.39	-	-	-	-	-	
<b>VIII</b>	76.33	-	-	-	-	-	-	-	-	76.33	
<b>total</b>	<b>98.22</b>	<b>95.44</b>	<b>88.89</b>	<b>74.77</b>	<b>114.37</b>	<b>97.68</b>	<b>145.42</b>	<b>86.96</b>	<b>29.52</b>	<b>111.13</b>	

A correlation-cum-regression analysis between work outlays, pure production and machinery substitution costs showed considerable dependencies only between the two first variables and the depending variable. Obviously, in the first case these features are correlated negatively, in the second case – positively. On the basis of Duncan test it can be concluded that average value of pure production obtained in simplification groups II and VII differs considerably and there are important differences between average value of technical equipping value between farms with I and IV degree of plant production simplification.

Table 2. Work efficiency according to the level of production simplification [PLN/working hours]

Simplification degree	total	farms								
		one way								two-way
		plant production				animal production				mixed production
		total	including			total	including			
vegetable	orchards		general plant	cattle	pigs		sheep			
<b>2002</b>										
<b>I</b>	3,78	3,22	3,22	-	-	4,06	-	5,29	2,82	-
<b>II</b>	11,80	14,28	16,03	4,77	25,90	6,15	-	6,15	-	7,10
<b>III</b>	11,13	11,34	10,74	8,33	13,75	12,51	10,62	14,39	-	4,92
<b>IV</b>	12,93	14,24	14,58	8,30	14,30	6,43	6,55	6,37	-	10,26
<b>V</b>	7,21	7,68	8,35	13,61	3,80	5,31	7,88	4,02	-	6,34
<b>VI</b>	7,59	7,74	7,41	-	8,01	-	-	-	-	6,91
<b>VII</b>	4,78	5,92	5,89	-	5,95	-	-	-	-	2,51
<b>VIII</b>	-	-	-	-	-	-	-	-	-	-
<b>total</b>	<b>9,84</b>	<b>10,79</b>	<b>10,95</b>	<b>8,31</b>	<b>11,15</b>	<b>6,77</b>	<b>8,35</b>	<b>6,66</b>	<b>2,82</b>	<b>7,27</b>
<b>2007</b>										
<b>I</b>	5,24	6,39	-	6,39	-	2,95	-	-	2,95	-
<b>II</b>	16,14	17,28	19,77	16,80	8,72	7,05	-	7,05	-	-
<b>III</b>	12,35	12,68	11,56	-	17,73	10,40	9,29	10,95	-	13,09
<b>IV</b>	12,47	13,28	13,60	19,96	11,47	5,48	6,34	4,62	-	11,91
<b>V</b>	11,29	11,06	10,84	11,92	11,34	15,51	-	15,51	-	10,89
<b>VI</b>	9,69	10,30	11,21	-	8,66	7,19	11,16	3,22	-	9,08
<b>VII</b>	13,08	13,08	17,87	-	10,69	-	-	-	-	-
<b>VIII</b>	5,73	-	-	-	-	-	-	-	-	5,73
<b>total</b>	<b>11,62</b>	<b>12,20</b>	<b>12,51</b>	<b>13,58</b>	<b>11,20</b>	<b>8,87</b>	<b>8,93</b>	<b>9,69</b>	<b>2,95</b>	<b>10,61</b>

On farms which specialise in plant production both the indicator of technical equipping and of work efficiency in groups with higher level of production simplification were almost twice as high as in groups with lower level of simplification. On the other hand, on farms with animal and mixed production these indicators had highest value in middle groups, that is, with level of simplification III and IV.

On the basis of statistical analysis it can be concluded that to increase work efficiency by 1 PLN per working hour it will be necessary to increase pure production by 1.04 thousand PLN /ha with a decrease of outlays by 0.55 working hours/ ha. Duncan test showed important differences in average value of pure production between II and VII groups of simplification and the indicator of technical equipping between I and IV group of simplification.

## Reference

Michałek R. et al. [1998]. Uwarunkowania technicznej rekonstrukcji rolnictwa. PTIR, Kraków. pp. 29-35

## **PLACING PLANT PROTECTION PRODUCTS ON THE POLISH MARKET WITH REGARD TO THE REGISTRATION OF INDIVIDUAL FORMULATIONS**

*Ewa Matyjaszczyk*

*Plant Protection Institute, Poznań, POLAND*

*e-mail: E.Matyjaszczyk@ior.poznan.pl*

**Keyword:** plant protection products; formulation of plant protection products; registration of formulations in Poland; registration of plant protection products

### **Introduction**

The regulations of the European Union concerning agriculture and plant protection aim to ensure the human's safety and the environment's preservation. The EU regulation concerning environmental protection consists of about 70 directives, which have been revised and amended many times, as well as 21 regulations [1]. The rules of the European Union regarding plant protection should ensure that in agriculture, only the agrochemicals which are thoroughly studied and fulfil the high EU requirements regarding safety are used.

### **Discussion**

The influence of agrochemicals on the environment depends not only on their chemical composition, but also on crop protection techniques and physical forms (so called formulations). The main component of the plant protection products used in agriculture is the active substance. The active substance is the main factor which eliminates harmful organisms. Apart from this, plant protection products also contain other components (liquid or solid). Their aim is to give the active substance desirable physicochemical features, to increase safety of application, to facilitate application, and in some cases also to increase the toxic effect on agrophages. The mixture of the active substance with the other components of plant protection products is called the formulation [2].

According to the Polish law, it is obligatory that the trade name of the plant protection product must contain the formulation code. The list of formulations of plant protection products used in Poland with codes and short descriptions is given in the Ministry of Agriculture and Rural Development's regulation of the 8th of June 2004 [3].

The following formulations of plant protection products are used most frequently in Poland [4]:

- powders for dry seed treatment - DS
- water dispersible powders for slurry seed treatment - WS

- suspension concentrate for seed treatment – FS
- solutions for seed treatment - LS
- emulsions for seed treatment – ES
- emulsifiable concentrate – EC
- aqueous suspension concentrates – SC
- soluble concentrates – SL
- emulsions: water in oil – EO, oil in water – EW
- capsule suspension - CS
- suspo-emulsion – SE
- water dispersible granules - WG
- soluble granules - SG
- wettable powders - WP
- water soluble powders – SP
- granules - GR

The formulation of a given plant protection product is closely connected with the method of its application which influences not only the agronomical efficacy but also the impact on the environment. For example, free-flowing powdered forms of plant protection products to apply by dusting (dustable powders - DP), which were commonly used some time ago, are prone to drift due to the wind, settling on objects and crops that are not the target of application – in this way they may pose a hazard. Therefore, at present this formulation has been almost completely withdrawn from use. The formulations regarded as modern are microcapsules, microemulsions and suspoemulsions, concentrated suspensions, different forms of granulates and forms facilitating preparation of spraying liquid such as water soluble bags. The use of granules limits wind-drift during the preparation of spraying liquids when compared to traditional forms of suspensions. There are opinions that the tendency to eliminate solvents from the group of aromatic hydrocarbons (formulation EC) and replacing them with biodegradable products of plant origin (EO, EW) is noticeable [5]. At present, in the proposed changes to the European Union regulations regarding plant protection products, there is a tendency to reduce the number of air applications where possible – the main reason is also the wind-drift of plant protection products.

The analysis of data regarding the placement and withdrawal of plant protection products on the Polish market in the first three years of EU membership (01.05.2004 – 30.04.2007) can provide information about current trends in registration formulations of plant protection products in Poland.

First to perform an analysis of registered and withdrawn formulations, the most important facts regarding registration of plant protection products in Poland after accession should be presented. The requirements regarding

placing plant protection products on the market of EU member states are presented in the Directive 91/414 [6]. The main deed which implements the requirements of the Directive 91/414 to the Polish law is the Plant Protection Act of 18<sup>th</sup> of December 2003 [7]. Because of high requirements regarding safety of the environment, active substances which do not fulfil the requirements have been withdrawn from the EU market, as well as the active substances for which the necessary studies have not been performed (so their safety has not been proven). Therefore, in the European Union the number of active substances allowed for use in plant protection is decreasing. This is accompanied by a decrease in number of registered plant protection products in most member states (including Poland).

In Poland, the withdrawal of plant protection products from the market as an effect of the continuous reduction in the number of approved active substances is accompanied by delays in registration. The main reason for delays is probably the fact that new procedures introduced in Poland after EU accession are still not working efficiently enough. As an effect, a decrease in the number of plant protection products placed on the market can be observed in Poland. During the first three years of EU membership, this decrease came to 8.5% and at the end of the analyzed period - the 30<sup>th</sup> of April 2007- the number of products placed on the market amounted to 821 [8].

It should be stressed that for the analysis performed in this paper, only plant protection products with a formulation code were considered. According to the legal requirements in Poland, all trade names of plant protection products should include the formulation code. However, there are a few rare cases when it is not possible – for example when the registered product is a packet containing two different plant protection products with different formulation codes.

Table 1 shows the formulations and number of products registered in Poland or withdrawn from the Polish market during the first three years of EU membership.

Before performing a more in-depth analysis of the data in Table 1 it should be emphasized that because of the fact that in the recent years the products withdrawn outnumbered those newly registered, the higher number of withdrawn products with a given formulation code in comparison with the products newly registered does not always show the tendency of withdrawing these formulations from the market. Moreover, some formulations are used more often than others. This is also reflected in Table 1 (as well as among the products registered and those withdrawn).



Table 1. Formulations of plant protection products placed on the Polish market\* and withdrawn in the period 01.05.2004 - 30.04.2007

Formulation code	Formulation	Number of plant protection products withdrawn	Number of plant protection products placed on the market*
AE	aerosol dispenser	4	-
AL.	liquid to be applied undiluted	7	4
CG	capsulated granules	1	-
CS	aqueous capsule suspension	1	4
DC	dispersible concentrate	1	-
DS.	powder for dry seed treatment	2	1
EC	emulsifiable concentrate	36	27
EO	emulsion: water in oil	-	1
EW	emulsion: oil in water	4	4
ES	emulsion for seed treatment	1	-
FK	smoke candle	2	-
FS	suspension concentrate for seed treatment	1	9
FU	smoke generator	-	1
GB	granulated bait	-	1
HN	hot fogging concentrate	1	-
LA	Lacquer	-	1
OD	oil suspension	-	2
PA	Paste	2	4
PC	gel or paste concentrate	1	1
PR	plant rodlet	1	-
PS	seed coated with a pesticide	-	1
SC	aqueous suspension concentrate	31	28
SE	aqueous suspo-emulsions	1	2
SG	soluble granules	3	-
SL	soluble concentrate	27	11
SP	water soluble powder	3	-
WG	water dispersible granules	7	13
WP	wettable powders	28	6
XX	Others	-	7
Total	-	165	128

\* With the products re-registered

Source: original work based on data from the Ministry of Agriculture and Rural Development

Table 1 shows that among both products withdrawn and registered, there is a clear domination of some types of formulations. There are also a number of formulations for which only a few products were registered or withdrawn. The most common formulations are intended to produce spraying liquid. Therefore, their popularity follows the fact that spraying is the most often used method of plant protection products application.

Among the products withdrawn, emulsifiable concentrates, aqueous suspension concentrates, wettable powders and soluble concentrates dominated. Less numerous were the withdrawal of formulations of water dispersible granules, liquids to be applied undiluted, aerosol dispensers,

emulsions: oil in water, soluble granules and water soluble powders. For the other formulations one or two products at the most were withdrawn.

Among the products registered (or re-registered) the formulations of aqueous suspension concentrate and emulsifiable concentrate dominated – similar results were also noted among products withdrawn. Formulations of wettable powders and soluble concentrates among products withdrawn were significantly less numerous. More numerous were suspension concentrates for seed treatment, water dispersible granules, aqueous capsule suspensions and preparations with the formulation code XX – others.

The data given above confirm the tendency to register plant protection products in the formulations considered to be safe like granulates and capsules. Likewise, the data confirm the tendency to withdraw powders (like wettable powders or water soluble powders) which, due to drift, can endanger the health of the user preparing the spraying liquid. Attention should be drawn to the fact that the most significant cause of cases of professional poisoning in agriculture is the drift of powder during preparation of a given spraying liquid [9].

The tendency, mentioned in literature, to eliminate the products in form of emulsifiable concentrate (EC) and replacing them by emulsions water in oil (EO) and oil in water (EW) was however in last three years not strong in Poland. The number of EC withdrawing was higher than the newly registered. The number of EO registration equals the withdrawing (4 products). While in the case of products with the EW formulation, there was only one product registered (0 withdrawn). Therefore, among the formulations registered, emulsifiable concentrates (27) significantly outnumbered EO and EW formulations (5).

## **Conclusion**

In this paper, on the basis of a short review of formulations placed on the market and withdrawn from use in Poland during the first three years of EU membership, it may be stated that in the analyzed period a radical withdrawal or placement on the market of products of a particular formulation did not take place. However, the tendency to limit the number of formulations regarded as less safe (e.g. powders) and increase the number of formulations regarded as more environmentally friendly or facilitating application (e.g. granulates or capsules) was noticeable. This tendency is favourable.

## References

- [1] Herma A. 2004 „Wymogi UE dotyczące ochrony środowiska”.  
<http://www.parp.gov.pl/partnerinfo/przewodnik/13dz14.rtf>
- [2] Pruszyński S., Podgórska B. 1994. Poradnik ochrony roślin, praca zbiorowa Instytut Ochrony Roślin Poznań 1994, 164 p.
- [3] Rozporządzenie Ministra Rolnictwa i Rozwoju Wsi z 8 czerwca 2004 w sprawie wymagań dotyczących treści etykiety-instrukcji stosowania środka ochrony roślin Dz. U nr 141 poz 1498
- [4] Wachowiak M. Uwagi i zalecenia dotyczące techniki wykonywania zabiegów ochrony roślin w: Zalecenia ochrony roślin na lata 2006/2007 cz. I Wykaz środków ochrony roślin ustawodawstwo i zasady bezpieczeństwa dla ludzi, zwierząt i środowiska. Instytut Ochrony Roślin w Poznaniu
- [5] Siłowiecki A. 2007. Formy użytkowe środków ochrony roślin. Ochrona Roślin nr 2, pp. 26-28
- [6] Council Directive 91/414/EEC of 15 July 1991 concerning the placing of plant protection products on the market Official Journal L 230 , 19/08/1991 P. 0001 0032
- [7] Ustawa z dnia 18 grudnia 2003 o ochronie roślin (Dz.U. z 2004r. nr 11, poz. 94)
- [8] Data according to the Ministry of Agriculture and Rural Development  
[http://www.bip.minrol.gov.pl/FileRepozytory/FileRepozytoryShowImage.aspx?item\\_id=3887](http://www.bip.minrol.gov.pl/FileRepozytory/FileRepozytoryShowImage.aspx?item_id=3887)
- [9] Ilnicki P. 2004. Polskie rolnictwo a ochrona środowiska. Wydawnictwo Akademii Rolniczej im. Augusta Cieszkowskiego w Poznaniu p. 447

## **THE ASSESMENT OF PRODUCTION SUSTAINABILITY IN FARMS ON THE BASE OF NITROGEN, CARBON AND ORGANIC MATTER BALANCE**

*Kazimierz Piekut<sup>1</sup>, Mirosław Machnacki<sup>2</sup>*

*<sup>1</sup> Warsaw University of Life Sciences, Department of Environmental Management,  
Warszawa, POLAND*

*e-mail: kazimierz\_piekut@sggw.pl*

*<sup>2</sup> Warsaw University of Life Sciences, Department of Economics and Organization  
Agricultural Enterprises, Warszawa, POLAND*

*e-mail: miroslaw\_machnacki@sggw.pl*

**Keywords:** sustainability assessment, balance of carbon and nitrogen, balance of soil organic matter, production direction

### **Introduction**

Agroecosystems are defined as open systems receiving from and losing to outside matter and energy. Energy and matter to agroecosystem inflow from natural sources and as a result of farmer activity. Owing to inflow in production means farmers increase production capacity to respectively high level. Specialisation, intensification of production and introduction to agroecosystems big amounts of production means strongly interference in natural cycling of energy and matter, leading to negative effect on environment. It is evident from western countries experiences and this country as well (Brouwer F., 2001; Goodlass at al, 2001; Fotyma at al, 2000; Liziński, 1997).

Impact of agriculture on natural environment as a whole is multidirectional and depends upon farms balancing grade. Environment impact assessment of basic production unit is complex. It can be assessed in one area and other as positive or negative. For the need of enterprises appeared in this respect integrated methods of enterprises or production processes assessment (Ejdys, 2003; Golinger-Tarejko, 1998). Environment is complex feature and in this respect impact of economy units is multi-directions in character. Methods aiming working out synthetic indexes regarding grade of enterprises balance are based on criteria of importance and weight assigned obtained values of sub indicators. Those attempts of obtaining one indicator for economic-ecological are less comparative. Therefore there is a lack of method of integrated assessment of farms.

The aim of this work is determination of state of equilibrium of agroecosystems on the base of nitrogen and carbon flow and soil organic matter balance in dependence to production direction.

## Material and method of studies

Studies have been carried on population of farms, which keep accountancy books for the needs of the Institute of Agricultural Economics and Food Economy in the years 1998 and 1999. From those group farms over 10 ha size representing the following production; plant - 138 farms, dairy - 133 farms, pig - 280 farms and beef cattle - 47 farms. Generally, studies covered 598 farms with general area of 25386.21 ha of agricultural land.

On the base of data from agricultural accountancy books the list of products and substances inflow to farms (purchases and gifts) and outflow (sale and gifts) was established. For those products the content of nitrogen and carbon were calculated. On the base of magnitude of purchases, gifts and sale and calculated indicators the amount of nitrogen and carbon for particular position on side of inflow and outflow were calculated. Similar solutions for working out balance of nitrogen on the farm entrance level have been applied by Pietrzak (1996) and Onema (1999).

Balance of soil organic matter was prepared on the base of structure of agricultural land and crop area structure assuming that on permanent grassland relative equilibrium between accumulation and decomposition of organic matter is occurring. On the contrary on arable land cultivation of certain crops leads to decrease and cultivation another ones to increase of organic matter content in soil (Fotyma and Mercik 1995).

## Results

### *Inflow and outflow of nitrogen and carbon*

Total inflow and outflow and nitrogen balance – emission for compared production directions presents figure 1. Inflow and outflow of carbon and retention for compared production directions presents figure 2.

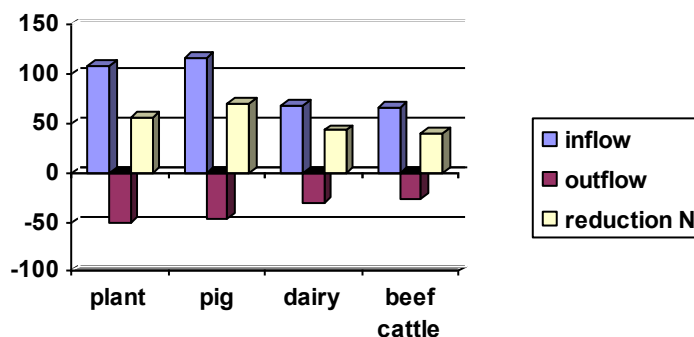

Figure 1. Inflow of nitrogen in production means and outflow in agricultural products and emission for compared production directions [kg per 1 ha of agricultural land]

Results presented in the figure 1 show that the highest inflow of nitrogen in production means distinguish itself pig direction - 116 kg N per 1 ha of agricultural land, a bit lower plant direction – 108 kg N/ha, but the lowest beef cattle where nitrogen inflow amounted 67 kg per 1 ha of agricultural land.

The highest outflow of nitrogen in agricultural production distinguished plant direction– 51 kg next pigs’ 46 kg N per 1 ha of UAA. For directions beef cattle and dairy agricultural production contained respectively 26.8 and 31.1 kg of nitrogen per 1 ha UAA.

Emission of nitrogen calculated from difference between inflow in production means and outflow in agricultural products was the highest for pig direction – 69,95 kg/ha, next for plant direction 56,33 kg/ha. Dairy direction characterised itself N emission at the level 43,03 kg/ha and beef cattle – 40,17 kg/ha. Analysis of data presented in fig. 2 shows that inflow of carbon in production means for plant direction amounted 119.25 kg C per 1 ha of agricultural land. For the rest of directions inflow of carbon was decidedly lower- from 236.56 kg/ha – dairy farms, 399.65 kg/ha for beef cattle and 565.62 kg/ha for pig direction. The highest outflow of carbon in agricultural products characterised plant direction– 1252 kg/ha, next pig 741 kg/ha, dairy direction 479.6 kg/ha and beef cattle – 283.29 kg/ha.

Carbon retention calculated as a difference between inflow and outflow for plant direction amounted 1132.88 kg/ha, for pig direction – 249.96 kg/ha, and for dairy – 243.04 kg/ha. But beef cattle distinguished itself negative retention of carbon at magnitude of 116.36 kg/ha of agriculture land.

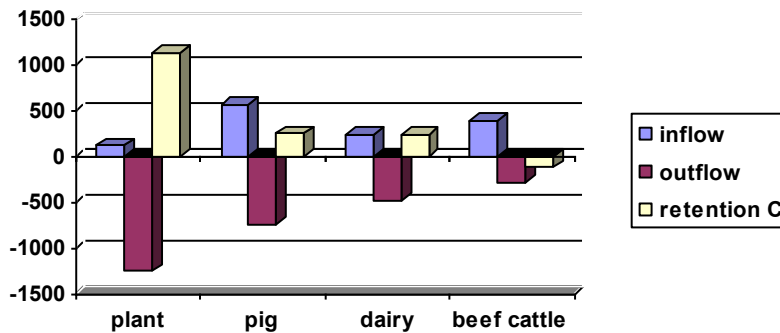

Figure 2. Inflow of carbon in production means and outflow in agricultural products and retention for investigated production directions [kg/ha of agricultural land]

### ***Balance of soil organic matter***

Data presented in table 1 show that agricultural land structure on plant and pig farms was disadvantageous. Permanent grassland covered only 2.70% and 7.03% of agricultural land. In this respect situation on dairy and beef cattle was significantly advantageous. Grassland amounted here respectively 36.63% and 38.56% of the utilised agricultural area.

In the crop area structure of plant and pig farms have dominated plants, which cultivation lead to decreasing of soil organic matter amount; cereals, oils, corn and row crops. Share of plants rising content of soil organic matter; pulses, field grasses and leguminous plants was small and amounted respectively 2.28 and 6.44%. On dairy and beef cattle farms plants rising organic matter content in the soil covered 22.61 and 14.16% of the sown area.

Table 1. Share of permanent grassland, crop area structure and balance of organic matter for compared production directions

Specification	Production direction			
	Plant	Pig	Dairy	Beef cattle
<i>% of grassland</i>	2,70	7,03	36,63	38,56
<i>Cereals</i>	67,63	80,45	60,25	69,76
<i>Rapes</i>	16,71	3,81	0,09	3,11
<i>Corn</i>	5,18	3,30	8,60	2,18
<i>Row crops</i>	7,22	5,85	6,45	8,91
<i>Pulse</i>	1,76	5,02	2,47	4,55
<i>Field grass</i>	0,42	0,68	15,76	7,32
<i>Legume</i>	0,10	0,74	4,39	2,29
<i>Other plants</i>	0,96	0,15	1,96	1,87
<i>Balance of o.m. t/ha sown area</i>	-0,614	-0,538	-0,281	-0,411
<i>Balance of organic matter t/ha agricultural land</i>	-0,595	-0,490	-0,172	-0,263

The most disadvantageous state in the respect of soil organic matter balance was found for plant direction. Annually per 1 ha of the sown area diminished 0.64 t of organic matter, and per 1 ha of agricultural land 0.595 t. Similar soil organic matter balance was stated for pig direction – 0.538 t per 1ha of sown area and –0.490 t per 1 ha of agricultural land. Farms with cattle production distinguished better balance of organic matter, especially dairy. This one distinguished the lowest negative balance of soils organic matter among compared direction of production; – 0.281 t/ha of sown area and –0.172 t/ha of agricultural land.

## Summary and discussion

Results of investigated elements of nitrogen and carbon balance sheet point that the analysed direction of agricultural production should include low input systems. In compared production direction the highest inflow of nitrogen in production means distinguished itself pig direction, where it amounted 116.06 kg per 1 ha of UAA, next plant direction – 108.10 kg/ha, dairy – 74.18 kg and beef cattle – 66.99 kg. Combined input of nitrogen and carbon in production means to farm amounted from 227 kg/ha for plant direction, 311 kg for dairy direction, 467 kg for beef cattle to 682 kg/ha for pig direction. For comparison on Dutch dairy farms balance sheet surplus of nitrogen alone amounts 300 kg/ha (Brouwer 2001). Surplus of nitrogen on Dutch farms frequently exceeded 400 kg/ha (Goodlass at al., 2001).

In the compared production directions the highest nitrogen emission distinguished pig direction – 69.95 kg/ha, next plant 56.33 kg/ha. Lower emission of nitrogen characterised dairy farms 43.03kg/ha and beef cattle 40,17 kg/ha. In present studies average emission of nitrogen to environment for compared farm group were generally lower than in similar studies done by Majewski et al., (2001). It resulted from facts that in balance sheet the inflow from natural sources were not taken into account. Considering natural inflows leads to overestimation of negative impact of agriculture on environment, especially low input farms and do not give real picture of farm management impact on emission magnitude. Thought intensification of agricultural production as a role lead to increase of negative impact on environment, however from economic point view can be acceptable since production unit can be aggravated by lower emission of nitrogen to environment (Picket at al., 2002,).

Obtained results have showed that the analysis of negative impact of agriculture on environment only by nitrogen emission prism is less advantageous for plan direction, where growth of nitrogen fertilisation usually leads to increase of its emission to environment. Considering however the carbon bonding, the negative effect of fertilisation is compensated by increased carbon retention. In plant farms nitrogen emission to environment was compensated by higher carbon retention (net) in agricultural product - 1133 kg per 1 ha of UAA. For the remaining production directions, carbon retention were significantly lower and amounted 243 kg/ha for dairy, and 250 kg for pig farms. But for beef cattle direction the emission of carbon was in quantities of 116 kg/ha UAA.

Balance of soil organic matter resulting both from agricultural land use structure and structure of sown area proves disadvantages effect of specialisation on ecological equilibrium of production system. In farms specialised in field production on 1 hectare of UAA diminish annually 0.595 t dm of organic matter. In two-directional pig farms balance of soil organic



matter was a little better – 0.538 t per 1ha of sown area and – 0.490 t per 1 ha UAA. Farms with cattle production distinguished themselves much better balance of soil organic matter, especially dairy direction. From the compared production directions this direction characterised at least negative balance of soil organic matter; – 0.281 t/ha of sown area and –0.172 t/ha of UAA.

From the comparison of magnitude of nitrogen emission, carbon retention and balance of soil organic matter results that for compared production directions the highest ecological equilibrium distinguished itself dairy farms. Plant and pig directions characterised much lower ecological equilibrium on which comprised higher nitrogen emission to environment and less advantageous balance of soil organic matter.

From the point of the three discussed farm sustainability indicators estimation of the particular production direction is different. An economic appraisal of mitigation measure in farms requires synthetic method of environment impact assessment. In this situation appears a problem of working out weights based on criteria of indicators ecological importance. The necessity of possessing very detailed data is problem for complex assessment of farm impact on environment. One of the possible data sources can be properly working out farm account system.

## References

- Brouwer F. 2001. Policy-technology interaction for intensive farming systems: some experiences from the Netherlands. In: Adoption of technologies for sustainable farming systems. Wageningen Workshop Proceedings, OECD, pp. 108-119.
- Ejdys J. 2001. Metodyka zintegrowanej oceny efektywności systemu zarządzania środowiskowego. *Ekonomia i środowisko* nr 1; 23-41
- Fotyma M., Mercik S. 1995. *Chemia rolna*. PWN, pp. 359.
- Fotyma M., Igras J., Kopiński J., Głowacki M. 2000. Bilans azotu, fosforu i potasu w rolnictwie polskim. *Pamiętnik puławski*, z.120, pp. 91-99.
- Golliner-Tarajko M.1998. Analiza wskaźnikowa w ocenie jakości ekologicznej procesów technologicznych. *Zesz. Nauk. AR w Krakowie* nr 508, pp. 30-39
- Goodlass G., Halberg N., Verschuur G. 2001. Study on Input/Output Accounting Systems on EU agricultural holdings. Centre for Agriculture and Environment. Utrecht CLM489-2001, pp. 82.
- Liziński T. 1997. Uwarunkowania rozwoju gospodarstw rolniczych na obszarach dolinowych w perspektywie stowarzyszenia Polski z Unią Europejską; *Gospodarstwo rolnicze wobec wymogów współczesnego rynku i Unii Europejskiej*. Wyd. SGGW, Warszawa, pp. 202-210.

- Majewski E., Łabętowicz J., Wiśniewski J. 2001. Bilans azotu. In: Jakość zarządzania w gospodarstwach rolniczych w Polsce w świetle badań. Wyd. SGGW, pp. 121-133.
- Majewski E. (red), 2001. Jakość zarządzania w gospodarstwach rolniczych w Polsce w świetle badań. Wyd SGGW, pp. 184.
- Onema O. 1999. Nitrogen cycling and losses in agricultural systems. [In:] Nitrogen cycle and balance in Polish agriculture, IMUZ Falenty, pp. 25-43.
- Piekut K., Machnacki M., Pawluśkiewicz B. 2002. The balance of nitrogen and carbon on polish farms with a different direction and intensity of production. Prace Poznańskiego Towarzystwa Przyjaciół Nauk. Wydział Nauk Rolniczych i Komisji Nauk Leśnych; vol. 93, pp. 121-129

## **DROPLETS SIZE MEASUREMENT BY ELECTROSTATIC METHOD APPLIED TO AGRICULTURAL NOZZLES**

*Dariusz Plichta*  
*Agricultural University in Lublin, POLAND*  
*e-mail: dplichta@poczta.onet.pl*

**Keyword:** nozzle, spraying, droplets size, electrostatic

### **Introduction**

Spraying liquids is nowadays a widely practiced procedure in industries such as construction industry, varnishing, agriculture and food industry (Orzechowski Z. et al., 1994). Atomization of liquids in agriculture is particularly crucial in the case of crop protection and fertilizing.

In the mentioned usage one of the most fundamental conditions for the correct course of the technological process is to obtain, during spraying, droplets of the size precisely defined by the technological requirements. However, the process of forming a drop of liquid in course of spraying is extremely complex and it depends on the liquid properties such as stickiness, surface tension and the spray apparatus, namely pressures, shape and condition of the nozzle. Interaction of these factors causes considerable changes in the distribution of the size of drops obtained during spraying. The process of the size measurement as well as the distribution of droplets coming out of the nozzle is very difficult; more specifically if the measurement is carried out directly at the nozzle's production instead of a specialist laboratory.

### **Methods and material**

Droplet size measurement by electrostatic method is based on the capability of the liquid to carry electrical charges at a considerable distance. Moreover, the size of the charge is proportional to the mass of the charged droplets (Geist J.M. et al., 1951; Kuna-Broniowski M., 1999).

A specific electrode collecting the charged droplets allows us to measure the droplets size. The charged droplet is characterized by a precise capacity which depends on the liquid properties and on the droplet size itself. Assuming that the droplet size and liquid properties are constant during the measurement, one can consider that each droplet of the same size is characterized by an identical capacity.

$$q_a = C \cdot U \quad (1)$$

where :

- $q_a$  – charge of the drop,
- $C$  – capacity of the drop,
- $U$  – electric tension.

The charge of the droplet thus depends only on electric tension. The charge carried by droplets is directly proportional to their size. A measurement tool based on this property has been developed (Kuna-Broniowski M. et al., 1994; Kuna-Broniowski M. et al., 1995). It allows to measure the size and number of droplets passing the measurement area covered by a detector. The detector, paired with a computer measure system provides instantly the droplet distribution spectrum. This system makes possible continuous control of spraying quality and allows us eventually to adjust the spraying parameters.

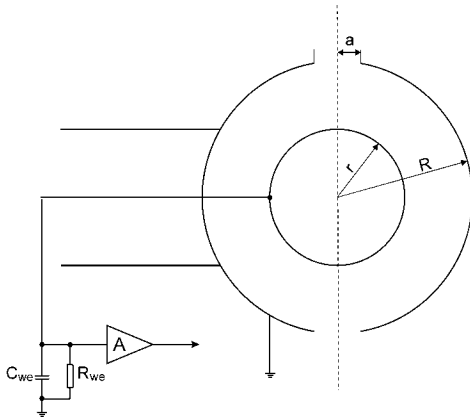

Figure 1. Diagram of measurement detector (A – amplifier,  $C_{we}$  – input capacity,  $R_{we}$  – input resistor, a – radius of input gate, b – collector's radius, R – spherical screen radius).

The signal of the used detector has been intensified with an instrumental differential amplifier. It allowed to eliminate the problem of interference in the process of measurement. The amplifier was placed directly at the detector in order to reduce the absolute input capacity, which, in turn, allowed us to increase the amplitude of the generated signals and decrease the susceptibility to interference.

A series of research on the spraying nozzles for pesticides application was conducted. The aim was to measure the size and number of droplets at the incidence plane of the sprayed stream by means of the electrostatic method of drop size measurement.

Sprayers were subjected to measurement by scanning of the incidence surface area by means of a measurement detector. The detector moved every 15 mm

in both directions parallel to the axis of a nozzle. Signals from the detector, intensified by the differential measurement amplifier, were classified by a comparative device from which the data was transferred to a computer and saved on the hard disk.

Sprayers subjected to examination were home products, namely rotational sprayers with output 1.0mm, 1.5mm, 2.0mm, and 2.5mm in diameter and gap nozzles, models RS110/02 , RS110/03 and RS110/04.

The droplets distribution were measured for different spraying pressures: 0.06MPa, 0.10 MPa, 0.20MPa and 0.30MPa. In each case the procedure was repeated three times.

Obtained results were directly analysed by a specifically designed computer application and visualized on the screen.

## Results

The detector moved every 15 mm in both directions parallel to the axis of a nozzle, which created a network of points on the tested surface. The drop registration on each of these points made possible the analysis of the drop range. The increasing number of points is parallel to the size of the outlet diameter; the bigger the diameter of the rotational sprayer outlet the more points at which droplets were observed. The number of measurement points at which drops were registered for the pressure value of 0.06MPa varied considerably depending on the diameter of the nozzle: in the case of 1.0mm in diameter – 150, whereas for the sprayer diameter of 2.5mm the number was 401 (see tab. 1).

Table 1. Number of measurement points for the different nozzle types and pressures

Pressure MPa	Nozzle type						
	φ 1.0 mm	φ 1.5 mm	φ 2.0 mm	φ 2.5 mm	RS 110/02	RS 110/03	RS 110/04
0.06	150	235	370	401	261	241	251
0.10	158	323	x	x	305	276	285
0.20	195	403	x	x	x	x	x
0.30	216	x	x	x	x	x	x

x - exceeded scope of scanned area

The size of the droplets produced by the 1.0mm nozzle for pressures 0.06MPa-0.30MPa was subject to analysis due to the fact that within the whole scope of pressures the stream of the sprayed liquid never exceeded the scanned area, thus produced droplets were always registered.

The most numerous class of the drop size is class I, in which for the rotational sprayer with 1.0mm in dimension the number of drops was 1361, 1570, 2308 and 2934 for working liquid pressures 0.06MPa, 0.10MPa, 0.20MPa and 0.30MPa respectively. The number of large droplets (class XII) was much lower: 443, 498, 646, and 618 for the respective pressures. It

should be noted that the pressure rise is accompanied by a more substantial increase in the amount of small drops when compared to the large ones. The ratios of the number of class XII drops to class I drops for the tested pressures were 0.33, 0.32, 0.28, and 0.21 respectively (see tab. 2).

Table 2 Distribution of the droplets following their sizes for the whole scanned area – rotational sprayer  $\varnothing$  1.0mm.

Pressure MPa	Drop size class												Sum
	I	II	III	IV	V	VI	VII	VIII	IX	X	XI	XII	
0.06	1361	480	252	165	125	117	66	68	58	60	124	443	3319
0.10	1570	501	332	201	157	145	115	108	92	91	143	498	3953
0.20	2308	883	540	354	284	210	216	144	116	139	208	646	6048
0.30	2934	1052	630	341	305	255	184	166	136	128	188	618	6937

## Discussion

In the light of the conducted research there are numerous advantages of the electrostatic method for droplets measurement. In comparison with traditional methods of capturing droplets, this method enables to measure larger number of drops. Application of methods offering similar results to the one presented here is extremely complex and expensive. Classification of the drop sizes directly by the measurement tool gives the opportunity to present the distribution of the droplets in an intuitive way on the computer screen immediately after the measurement. Furthermore, it allows analysis of only these drop sizes and scanned areas which are of our interest as an object of a more thorough study.

Here are the conclusions drawn on the basis of the research and its analysis carried out by means of the electrostatic method with the use of a measure appliance devised by the author.

- Research results obtained by the measurement device, after their analysis confirm theoretical hypotheses, including susceptibility to varied conditions of spraying of liquids, change of the pressure of the liquid, type and size of the sprayer,
- Designed and constructed by the author measurement device enabled statistic analysis of the distribution of the droplet size on the incidence plane. Analysis of the horizontal distribution aided by the droplet size measurement on the plane is possible for each size class.
- Changing the droplet size into electric signal at the level of the measurement detector provides the opportunity to transfer the data as electric signals into a computer and use the advantages of the information technology in the measurement process.

## References

- Geist J. M., York J. L., Brown G. G. 1951. Electronic spray analyzer for electrically conducting particles. *Industrial and Engineering Chemistry*. Vol. 43, No. 6.
- Kuna-Broniowski M., Ścibisz M. 1994. Measuring the currents of the drops to record the kinetic energy of rain splash. *International Conference on Agricultural Engineering*. Milano, 29.08-01.09, pp. . 83.
- Kuna-Broniowski M., Ścibisz M., Zdzioch J., 1995. High voltage application to measure the mass of water drop., *Ninth International Symposium on High Voltage Engineering*. Graz, 29.08-01.09, pp. 7893-1-2-3.
- Kuna-Broniowski M. 1999. Nowe metody prognozowania i wczesnego wykrywania chorób roślin. *Rozprawy Naukowe Akademii Rolniczej w Lublinie*. Lublin.
- Orzechowski Z., Prywer J. 1994. *Rozpylanie cieczy w urządzeniach energetycznych*. WNT. Warszawa.

## **FIELD TRIALS ON GRAIN MAIZE CULTIVATION TECHNOLOGIES IN 2004, 2005 AND 2006**

*Petr Šařec<sup>1</sup>, Ondřej Šařec<sup>1</sup>, Katarzyna Gil<sup>2</sup>*

*<sup>1</sup>Czech University of Life Sciences Prague, Department of Machinery Utilization,  
CZECH REPUBLIC*

*e-mail:psarec@tf.czu.cz*

*<sup>2</sup>Agricultural University in Lublin, POLAND*

**Keywords:** grain maize, reduced-tillage, ploughing, costs

### **Abstract**

The paper presents the results of field trials that assess influence of various technologies of maize-for-grain crop stand establishment on not only its yield, but also on labour and fuel consumption, and individual cost components. The field trials have been carried out since the year 2004 in all maize-growing regions of the Czech Republic. Farm businesses are monitored that perform either conventional technology of soil cultivation comprising ploughing or reduced-tillage technology. The trials showed no significant differences in grain yields between both technologies in question. On the other hand, labour consumption demonstrated highly significant differences, i.e. 56.2 % in favour of reduced-tillage. Significant differences in favour of reduced-tillage technology were proved as well with regard to fuel consumption, and machinery and total costs.

### **Introduction**

History of maize (*Zea mays*) extends nine thousand years backward, particularly in South America. Obviously, it had a significant influence on development of South-American culture. In spite of its tropical origin, maize is a crop that is grown nowadays in various climatic conditions. This practice has been enabled by evolvement of breeding, which resulted in the fact that solely hybrid seed is applied at the present time. Maize growers are thus wholly dependent on specialized seed improvers. Maize grown for grain plays an important role in alimentation of population, but as well in livestock feeding where it ranks among the most important feeding crops (Vrzal, J., Novák, D. et al., 1995).

In the Czech Republic, maize cultivation area increases yearly, e.g. from around 40 thousand hectares in the year 2000 to 100 thousand hectares in 2006.

Choice of a suitable variety depends mainly on nature and weather conditions of a grower. In the Czech Republic, varieties appropriate for various production areas are tested regularly. The key feature of a hybrid seed is the length of vegetative period that is indicated using the FAO scale as a number



in proportion to a standard. The number therefore doesn't represent any absolute length of vegetative period in days. In the conditions of the Czech Republic, a range of varieties starting with very early hybrids with 200 FAO, i.e. 120 days of vegetative period, to late hybrids with 600 FAO, i.e. 142 to 148 days of vegetative period, is used (Petr, J., Húska, J., 1997).

Moth-resistant Bt maize is one of the few genetically modified crops allowed for growing in the Czech Republic at the moment. From the selection of farm businesses where the field trials in question has been carried out, four farms use genetically modified seed already.

## Materials

The aim of the field trials, located in all regions of the Czech Republic, is to evaluate major technologies of crop stand establishment of maize grown for grain with respect to its yield, fuel and labour consumption, and costs, but as well other variables not mentioned in the paper such as soil compaction, soil pH, soil nutrition content, weed infestation etc.

The trials have been carried out in ten farm businesses where either conventional technology of soil cultivation comprising ploughing or reduced-tillage technology is applied. Besides ploughing, the two technologies in question differ as well according to organic fertilizer application, i.e. manure or slurry application. At all selected farms within one year, one field is monitored, or even more fields in the case of different soil cultivation technologies used.

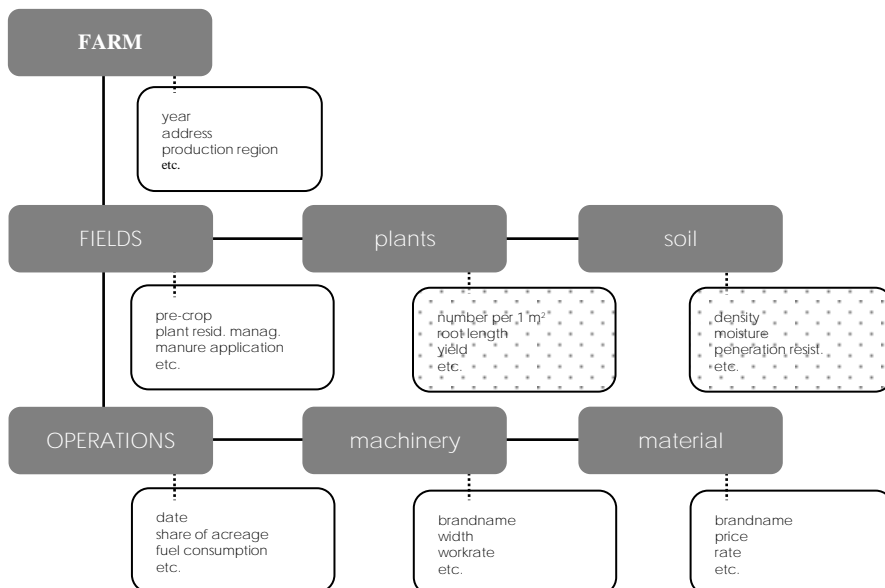

Figure 1. Chart describing the structure of field-trial data (items in dotted boxes are gained by measurement)

Data that are monitored within the trials (see Figure 1) concern overall characteristics of farm and field in question as well as particular information on plant and soil, and on all field operations that were carried out. The latter enables to enumerate costs of maize growing. Overhead costs and costs incurred due to land ownership or lease were not included.

## Results and Discussion

Example of a model technology for conventional as well as reduced-tillage technology is shown in Table 1. Some farm businesses applied manure or slurry prior soil tillage. The latter one could be applied as well after plant emergence. In those cases, unit costs show progressive trend with respect to the organic fertilizer rate.

Table 1. Basic model variants of field operations of conventional and reduced-tillage technologies monitored within the field trials

Field operation	Example of machinery and materials used
<b>CONVENTIONAL TECHNOLOGY</b>	
Stubble cultivation	JD-8200 + Horsch Phantom (6 m width)
Ploughing	Services: plough PHX 35
Mould clearing	JD-8200 + Horsch Phantom (6 m width)
Fertilization	JD-6720 + Amazone (24 m width, carbamide 300 kg.ha <sup>-1</sup> )
Fertilizer treatment	JD-8200 + Horsch Phantom (6 m width)
Sowing	Services: accurate seeder Kinze (seed 60 kg.ha <sup>-1</sup> + carbamide 30 kg.ha <sup>-1</sup> )
Spraying	Hardi Alpha Twin (30 m width, Guardian 2.5 l.ha <sup>-1</sup> + AtraneX 50 SC 1.5 l.ha <sup>-1</sup> )
Harvest	JD 2064 (six-row cornhead)
<b>REDUCED-TILLAGE TECHNOLOGY</b>	
Stubble cultivation	JD-8200 + Horsch Phantom (6 m width)
Cultivation	JD-8200 + Horsch Phantom (6 m width)
Fertilization	JD-6720 + Amazone (24 m width, carbamide 300 kg.ha <sup>-1</sup> )
Fertilizer treatment	JD-8200 + Horsch Phantom (6 m width)
Sowing	Services: accurate seeder Kinze (seed 60 kg.ha <sup>-1</sup> + carbamide 30 kg.ha <sup>-1</sup> )
Spraying	Hardi Alpha Twin (30 m width, Guardian 2.5 l.ha <sup>-1</sup> + AtraneX 50 SC 1.5 l.ha <sup>-1</sup> )
Harvest	JD 2064 (six-row cornhead)

Within reduced-tillage technologies, the most common tillage technology comprised of two cultivations, or of two cultivations followed by a seedbed preparation in spring. Cultivation to medium depth of around 0.08 to 0.010 m accounted for half of the soil tillage operations. An operation of deeper soil loosening (chiselling) was applied on one third of the fields treated by reduced-tillage technology. Maize yield from those fields reached in average 12.5 % higher figures.

Within conventional technology, the most common process comprised of one stubble cultivation, one ploughing and one or two operations of seedbed

preparation. Medium ploughing was the most frequent tillage operation. Compared to reduced-tillage technology, the share of soil tillage operations within conventional technology increased.

Over the whole period of three years of trials, the average maize grain yield of all the thirty-five trial fields attained 8.52 t.ha<sup>-1</sup>. Figure 2 shows average maize grain yields according to the cultivation technology and year. In all the three years, reduced-tillage technology reached higher average yields than conventional one. When compared to the conventional technology, the average yield of reduced-tillage technology was higher by 8.2 % over the three years. Uneven location of trial fields into production areas might have adverse effect on the results reached by conventional technology. Corn production area demonstrated the highest average yield that surpassed 10 t.ha<sup>-1</sup>, but within this area particularly reduced-tillage technology with new machinery of high work rate has been employed. Average grain yield varied in individual years, though the differences were only minor.

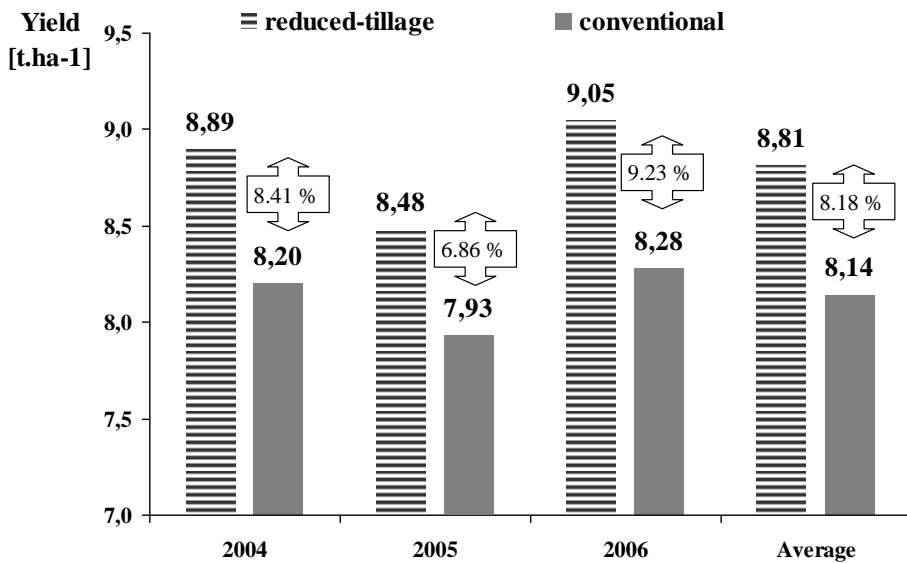

Figure 2. Yearly and average yields (grain maize) regarding the two cultivation technologies

Table 2 present average fuel and labour consumption, material and machinery costs and total costs, and average costs per one ton of maize grain produced.

Higher fuel and labour consumption was noted at conventional technologies. Overall reduction of fuel consumption over the three trial years reaches 24.1 % in favour of reduced-tillage technology. Even higher difference, i.e. 56.2 % in favour of reduced-tillage technology, could be noted within labour consumption. The differences' extent was influenced by field

operations of ploughing done for conventional technology where there were as well organic fertilizers applied more often.

Table 2. Average values of fuel and labour consumption, of individual cost components and of costs per unit of production, i.e. a ton of maize grain, according to cultivation technologies and years (figures in italic: statistically significant differences for  $p \leq 0,05$ )

Year and technology	Consumption		Costs (CZK.ha <sup>-1</sup> )			Costs per production unit (CZK.t <sup>-1</sup> )
	Fuel (l.ha <sup>-1</sup> )	labour (hour.ha <sup>-1</sup> )	material	machinery	total	
YEAR 2004						
Reduced-tillage	75.8	3.65	5 638	6 358	11 995	1 398
Conventional	99.7	8.25	6 233	6 747	12 980	1 596
YEAR 2005						
Reduced-tillage	74.9	3.49	5 580	6 225	11 805	1 425
Conventional	98.6	8.05	6 300	7 073	13 373	1 716
YEAR 2006						
Reduced-tillage	73.5	3.41	5 590	6 114	11 704	1 328
Conventional	97.0	7.79	5 840	6 993	12 833	1 568
YEARS 2004-2006						
Reduced-tillage	74.7	3.52	5 603	6 232	11 835	1 384
Conventional	98.4	8.03	6 124	6 938	13 062	1 627
TOTAL	84.9	5.45	5 826	6 535	12 361	1 488

Concerning economic aspects, reduced-tillage technology demonstrated lower material and machinery costs, thus as well lower total costs. Over the monitored period of three years, the difference in favour of reduced-tillage technology proved to amount to 8.5 % for material costs, 10.2 % for machinery costs, and 9.4 % for total costs. Since reduced-tillage technology generally reached higher maize grain yield, the costs per one ton of grain produced by reduced-tillage technology was by 14.9 %, i.e. by 243 CZK.t<sup>-1</sup>, lower than conventional one.

All the differences among variable averages in Figure 2 and Table 2 were statistically tested with respect to cultivation technologies within each year, to cultivation technologies for all three years together, and finally with respect to the year of cultivation. The latter one, i.e. the year of cultivation, didn't prove to influence significantly any of the mentioned variables, not even the grain yield. Within individual years of cultivation, only labour consumptions of different cultivation technologies varied significantly, and they did so within each of the three years in question (probability level  $p=0.007882$  in the year 2004,  $p = 0,000632$  in the year 2005,  $p = 0.034244$  in the year 2006). Over the whole period of three years of trials, differences between averages of variables with respect to different cultivation technologies proved significant for fuel consumption ( $p = 0.008912$ ), for labour consumption ( $p = 0.0000000003$ ), for machinery costs ( $p = 0.020860$ ), and for total costs ( $p = 0.012028$ ).

## Conclusions

Within the conditions of the Czech Republic, field trials focused on maize grown for grain were carried out in the years 2004 to 2006. These trials proved that maize can be cultivated using conventional as well as reduced-tillage technology. Reduced-tillage technology attained good results regarding labour and fuel consumption as well as regarding material and machinery costs. Costs of one ton of maize grain, which is the key criterion of successful growing for any farm business, were by 14.9 % lower for reduced-tillage technology than conventional one. Both cultivation technologies reached high quality grain yield, but there are still substantial reserves with respect to genetically modified seed.

## References

- Petr, J., Húska, J. 1997. Speciální produkce rostlinná– I. Praha: Agronomická fakulta ČZU v Praze, 1997, ISBN 80-213-0152-X
- Šařec, O. 1991. Zemědělská technika v podmínkách tržního hospodářství, Institut výchovy a vzdělávání MZe ČR, Praha 1991, ISBN 80-7105-024-5
- Šařec, P., Šařec, O., Horák, L., Šařecová, P. 2006. Technologické a ekonomické parametry pěstování řepky ozimé ve vybraných podnicích v letech 2001 – 2006. In 23. vyhodnocovací seminář „Systém výroby řepky, systém výroby slunečnice“, 22.-23. 11. 2006, Hluk, Praha: SPZO s.r.o., 2006. pp. 264-278. ISBN 80-87065-00-X
- Vrzal, J., Novák, D. et al. 1995. Základy pěstování kukuřice a jednoletých píceň. Praha: Institut výchovy a vzdělávání MZe ČR, 1995, 32 p.

*This work was supported by Research Project of the Ministry of Education of the CR no. MSM 6046070905, and by the project NAZVA QH72257.*

## **ESTIMATION OF INDICATORS FOR SUSTAINABLE AGRICULTURAL PRODUCTION**

*Józef Sawa*

*Agricultural University in Lublin, Department of Machinery Exploitation and Management  
in Agricultural Engineering, Lublin, POLAND*

*e-mail: jozef.sawa@ar.lublin.pl*

**Keywords:** standard area of farm for parity income, energy and material inputs, sustainability of agricultural production, intensity of production organization, organic matter balance

### **Abstract**

The level of sustainability of the agricultural production was analyzed for 42 farms situated in different regions of Poland using the European Standard Unit (ESU) index. Indicators have been used to define three categories of sustainable agricultural production: ecological, social and economic. These indicators were expressed numerically and they were analyzed in reference to the intensity of production organization, material and energy input, organic matter balance, labour work, economic-productive effects, etc. The indicator of a standard area of a farm for parity income was defined and determined and it was calculated for an average income obtained in the budgetary sphere. It was found that the accepted criteria of sustainable production process are not satisfied in the farms with the index lower then 16 ESU.

Increase of the size category expressed by ESU in the studied farms, with comparable material inputs, results in decreased energy input per ha arable land, but also increased energetic equipment of work (kWh/man hour work) and the market net production per worker expressed in cereal units. At the same time, a comparable level of the index of intensity of agricultural production organization and a remarkable increase of the level of the organic matter reproduction are observed. The studied farms can be divided into two groups, where the limit of the division is the category of size close to 16 ESU. Practically, it is only the farms of the size of 16 ESU and more that show sustainable production process in the sphere of ecological, social and economic requirements. The other two groups of the studied farms (about 30%) with the ESU index lower than 16 practically do not fulfill the quality demands. These farms do not have any possibility for the sustainable agricultural production process and, assigning the means that should be intended for accumulation for consumption, they limit the possibilities to modernize the process of production.

## **DEVELOPMENT OF A TESTING DEVICE FOR SPRAYING NOZZLES**

(Preliminary Investigation)

*Jozef Sawa<sup>1</sup>, Stanisław Parafiniuk<sup>1</sup>, Joanna Tarasińska<sup>2</sup>, Bruno Huyghebaert<sup>3</sup>*

*<sup>1</sup> Agricultural University in Lublin, Department of Machinery Exploitation and Management  
in Agricultural Engineering, Lublin, POLAND*

*e-mail: jozef.sawa@ar.lublin.pl*

*<sup>2</sup> Agricultural University in Lublin, Department of Applied Mathematics, Lublin, POLAND*

*e-mail: joanna.tarasinska@ar.lublin.pl*

*<sup>3</sup> Walloon Agricultural Research Centre, Gembloux, BELGIUM,*

*e-mail: huyghebaert@cra.wallonie.be*

**Keywords:** Sprayers inspection station, nozzles testing, testing device

### **Introduction**

Sustainable agriculture production is the result of the application of the Code of Best's Agricultural Productive Practice (DRPP) on the farms, based on rules of integrated production. Plant protection takes a great part in the sustainability of the Agriculture. Bad management and overuse of the chemical plant protection could lead to the disappearance of our traditional Agriculture. Sprayer in good state and well adjusted allows the farmer to apply correctly the plant protection products. The spraying nozzle is a wearing part of the sprayer, which needs to be tested and eventually changed from time to time. In the framework of a sprayer inspection, the ISO 13 790 proposes two technical ways for the nozzles checking: flow rate and spray pattern measurements. Till now, those both measurements have been realized separately with specific measurement systems.

AR-Lublin and CRA-W Gembloux have developed a new device to test the nozzles' performances allowing to realize simultaneously both measurements. The first results are presented in this paper.

### **Nozzle's performances**

The efficacy of the plant protection treatment depends mainly on the quality of the deposit: right quantity of active substance on the right target. Too small quantity may not give the waited effect, however too large quantity could lead to damage of the cultivated plants (phytotoxicity), to increase the treatments and to threaten human health and environment. Therefore also parameters of spray are very essential. Among many elements which affect the quality of spray, the technical state of the nozzles is important. After a long use, nozzles are worn and periodical check allows to verify their performances.

Even if a lot of parameters allows us to determine the nozzle's performances, such as: the nozzle output (l/min), the nozzles' cross-distribution, the individual spray pattern asymmetry, the spray angle, still the nozzle output and the cross-distribution are both the main used parameters.

ISO 5682-1 (1996) standard defines fully the measurement protocols and devices to determine the nozzle performances.

According to the ISO 5682-1, the individual nozzle spray distribution is measured on a 50 mm groove patternator. The ISO 5682-2 relating to the sprayer test defines a 100 mm groove patternator used to measure the spray pattern of a whole set of nozzles mounted on the sprayer boom.

The EN 12 761 relating to the new sprayer test define that the Coefficient of Variation of the spray pattern of the new flat fan nozzles should be  $< 7\%$  for the pressure and the boom height defined by the nozzles' manufacturer, and that the nozzles' output should be within  $\pm 10\%$  of the nominal output and  $\pm 5\%$  of the average output.

The EN 13 790 relating to inspection of the sprayer in use define that the Coefficient of Variation of the spray pattern of the used flat fan nozzles should not exceed  $10\%$ , and that the nozzles' output should be within  $\pm 10\%$  of the nominal output.

### **Testing device**

This device allows us to determine simultaneously the nozzle flow rate and individual spray pattern for a standardized working pressure and boom height. This device is designed to measure the performances of all types of nozzle.

The testing device is a kind of mini-sprayer equipped with two measurement systems: electronic flow meter and spray patternator (50 mm groove). All the measured data are automatically registered in a computer (Figure 1).



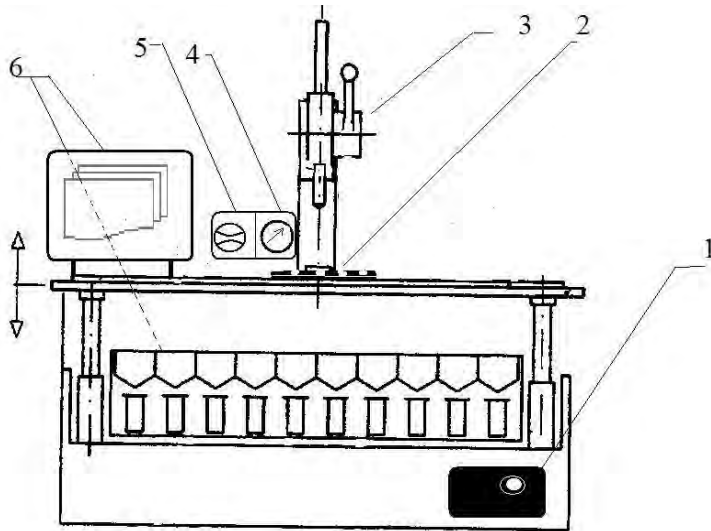

Figure 1. Testing device for flat agricultural nozzles  
 1- water tank, pump and filter, 2 - nozzles container, 3 - telescopic liquid feeder system, 4 - manometer, 5 - flow-meter, 6 - patternator, electronic measurement device and computer

## Software

The measurement are registered in a database and managed by the specific software. First, it allows to qualify the individual nozzle spray pattern (Figure 2), the spray angle as well as the individual spray asymmetry, spraying parameters as pressure, nozzle height and position being fixed.

Second, based on the individual spray pattern registered for each tested nozzle, the software allows to build a virtual spray boom of any length from the registered data relating to the tested nozzles. The position of the nozzles on the boom is randomly determined. The Coefficient of Variation (CV) of the simulated spray pattern is automatically calculated. A function of the software allows the operator to define the grooves' width (50 or 100 mm) of the virtual patternator.

Through an iterative process, the software finally allows to generate with the same set of nozzle a high number of different boom arrangement simply changing randomly the position of the nozzle.

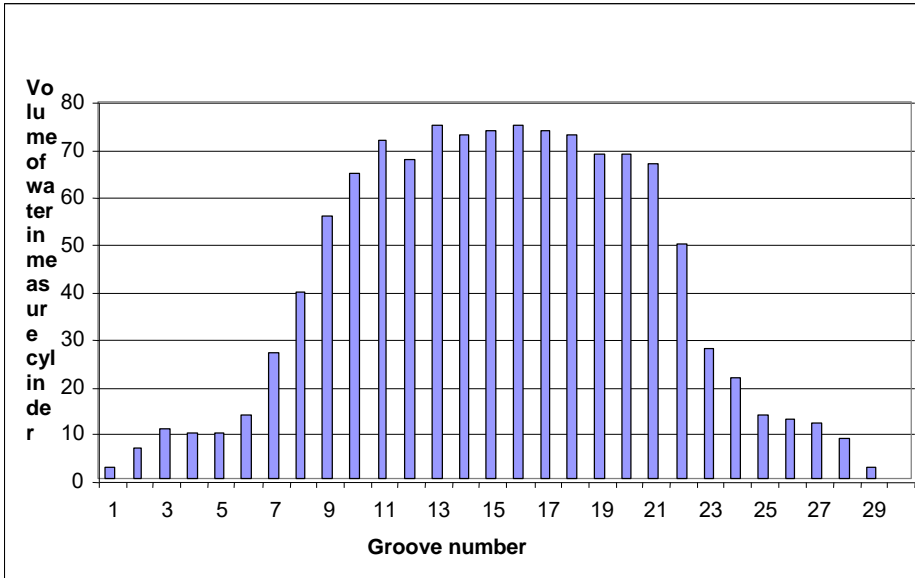

Figure 2. Individual nozzle spray pattern

### First results

27 flat fan nozzles (size 110 03), removed from agricultural sprayer in use, have been tested on the testing device. The output, spray angle, coefficient of asymmetry and the individual spray pattern of each tested nozzle have been registered in the data base.

The wear of the nozzles has been defined comparing the actual output and the nominal output at a given pressure. The wear of the first 24 nozzles doesn't exceed 3 %, while the one of the 3 last nozzles reach 13%.

From the 27 tested nozzles, five sets (A-B-C-D-E) of 24 nozzles (spray boom of 12 m) have been formed. The composition of the sets is the following :

1. Set A: 24 best nozzles;
2. Set B: best first used were replaced
3. Set C: best second used were replaced
4. Set D: best third used were replaced
5. First three best used were replaced with exchanged above characters.

For each nozzles set, the software simulates 10 000 different virtual spray boom. The CVs were calculated and the table 1 gives the descriptive statistics of the results.

Table 1. Results of the spray boom simulation for the 5 sets of 24 nozzles

Parameter	Set A	Set B	Set C	Set D	Set E
Minimum CV (%)	7,9	7,9	7,5	7,5	7,4
Maximum CV (%)	10,8	11,9	10,6	10,7	12,0
Average CV (%)	9,3	10,2	9,0	9,2	10,1
Standard deviation. (%)	0,41	0,56	0,43	0,45	0,58

Table 1 shows that the span between Min. CVs and Max. CVs is large. For all sets of nozzles, it is possible to produce a good CV (< 10 %), but also a bad CV (> 10 %), simply changing the position of the nozzles on the boom. For example, the extreme CVs for the set A were obtained for the following nozzles arrangements :

- Nozzles' position for CV min. (7.9%):  
[15,9,7,12,1,18,6,11,13,2,17,16,21,23,22,10,19,24,14,20,8,5,3,4];
- Nozzles' position for CV max. (10,8%):  
[9,3,18,13,6,4,15,16,8,22,19,5,12,20,2,14,7,11,17,23,24,1,21,10].

### First conclusions

The study allows to develop a new testing device to measure simultaneously the individual output and spray pattern of all types of nozzles. Moreover, the specific software has been developed allowing to register the individual measured parameters and to generate virtual spray boom based on the individual nozzles data. Finally, the software generates a high number of virtual spray boom based on the same nozzles' set allowing us to determine the best arrangement of these nozzles giving the lowest Coefficient of Variation of their spray pattern.

## **THE TIME OF ESTABLISHING OF THE MOISTURE CONTENT IN THE MIXTURE OF ORGANIC MATERIALS**

*Marek Ścibisz*  
*Agricultural University in Lublin, POLAND*  
*e-mail: marek.scibisz@ar.lublin.pl*

**Keywords:** *grain, moisture, microwave measurement*

### **Abstract**

#### **Introduction**

Moisture is the factor which strongly influences the property of the materials of biological origin. This concerns not only qualitative and gustatory questions but also technological, transportation or storage aspects. That is why the measurement of the moisture of organic materials is the frequent object of investigations.

Investigations related to the measurements of the average moisture value of sample were reported. There was no problem with the material which already stayed longer period of the time before processing. However, moisturizing joined with expectation on settlement of the schedule of moisture in the whole sample. According to the literature this period can even take up to a week.

This is the experimental finding for the case when the moisture is to homogeneous in the sample. The same approach is proposed for assessing such period for the rest of the material.

The experimental verification of this period until now was in considerably limited, because there were no simple devices enabling measurement of single elements of sample, such as e.g. seeds.

#### **Methods**

The new microwave measure was used in the work. Due to this method it is possible to qualify the schedule of moisture in the sample of the material. The arrangement of microwave homodyne bridge was applied in this method of measurement of moisture. It worked near the frequency of the electromagnetic wave 9.6 GHz.

The principle of the arrangement is based on the measurement of the bridge non-equal signals. Such situation is the result of the location in microwave line studied seed (Makarski, 2006).

The grains of lentils and soya bean were subjected to the investigation. Two samples of the same material of various moistures were stirred during the measurements. The moisture was measured after each 24 hour.

The measurement was made for one sample (the same during all research) and for samples taken to the measurement only once (after a period of the definite time).

It gave basis to assign the time after which settlement of the moisture in the joint mass of the grain followed.

### **References**

Makarski P. 2007. The measurement the moisture of small objects, particularly biological using the radiation of the microwave. The PhD thesis (in Polish). Supervisor: prof. Kuna-Broniowski M., Department of Engineering Production, Agricultural University in Lublin

## **MECHANIZATION OF INDIVIDUAL FARMS IN OPOLE PROVINCE**

*Tomasz Szuk*

*Wroclaw University of Environment and Life Sciences, Department of Economics and  
Organization of Agriculture, Wroclaw, POLAND*

*e-mail: Tomson@ekonom.ar.wroc.pl*

**Keywords:** mechanization, individual farm, technical condition

### **Introduction**

The mechanization in agricultural production is a must and something obvious irrespective of the kind and size of leading activity. However, the owners of large farms as well as small scale workshops have similar problem achieving high efficiency of mechanization. It is dependent on many economic-organizational factors, e.g. the degree of yearly utilization of equipment, quantitative and qualitative level of technical equipment as well as forms of use.

The present study makes quantitative and qualitative analysis of equipment in selected individual farms in Opole Province. Moreover the subject of the analysis is the degree of yearly utilization of equipment as well as forms of use.

### **Methods**

The investigations were conducted in June 2007 on 70 selected individual farms located in Opole Province. Questionnaire was employed to collect source materials. The main information collected relates to the characteristic of owner or manager of farm, specification of assets with special regard to machinery equipment, as well as estimation of mechanization costs, opinion on relating forms of machine use as well as intentions of equipment investment. The inquiry took place while the farmers underwent trainings done by Agriculture Advisory Centre in Łosiów.

The analysis used descriptive statistics methods as arithmetical mean, and variability coefficient.

### **Results**

The size of the farm in large measure determines its technical equipment and degree of mechanizing. Therefore the farms under consideration were divided into groups for which the detailed analysis was conducted (tab. 1).

Table 1. Division of farms according to utilized agricultural area

No.	Specification	Area groups (ha UAA)			
		up to 20.00	20.01-50.00	50.01-100.00	above 100.01
1.	Number of farms	24	22	18	6
2.	Average size of UAA (ha)	12.06	33.34	67.74	199.41
3.	Variability coefficient (%)	29.86	24.00	19.42	74.95

Source: Own study

The mechanization of farms depends strongly on the kind and size of the lead production, and on the available labour force (tab. 2). The detailed crop structure is presented in table 3.

Table 2. Labour force resources and level of animal production

No.	Specification	Area groups (ha UAA)			
		up to 20.00	20.01-50.00	50.01-100.00	above 100.01
1.	Labour force (persons/100 ha of UAA)	15.20	6.54	3.85	1.60
2.	Livestock density (livestock units/100 ha of UAA)	31.90	100.66	40.22	9.28
3.	In which cattle (LU)	9.40	52.02	3.60	0.00

Source: Own study

Table 3. Relative crop structure

No.	Specification	Area groups (ha UAA)			
		up to 20.00	20.01-50.00	50.01-100.00	above 100.01
1.	Total cereals (%)	60.31	74.25	69.15	72.90
2.	Winter rape (%)	32.53	17.51	23.02	25.19
3.	Sugar beet (%)	1.73	4.95	7.39	1.80
4.	Potatoes (%)	1.14	1.38	0.18	0.12
5.	Others (%)	4.30	1.90	0.27	0.00
6.	Total (%)	100.00	100.00	100.00	100.00

Source: Own study

The state of machinery level on the farm is determined by the condition of machinery equipment, and its cost, and is dependent mainly on its utilization as well as efficiency (Pawlak 1998). There are also others factors like the technical state of equipment, its parameters, modernity and compatibility. This concerns, first of all, the prime movers as well as so called leading machines, which because of its efficiency, price and relatively high exploitation costs influence strongly the mechanization unit costs. The level of equipment of the most important machinery is presented in table 4.

Table 4. Level of equipment of the most important machines

No.	Specification	Area groups (ha UAA)			
		up to 20.00	20.01-50.00	50.01-100.00	above 100.01
1.	Tractors per 100 ha of UAA	10.70	6.54	3.12	1.00
	Tractors per farm	1.24	2.18	2.11	2.00
2.	Combine harvesters per 100 ha (cereals and rape)	1.12	3.13	1.44	0.71
3.	Sugar beet harvester per 100 ha of sugar beet	20.00	23.87	8.37	-
4.	Potatoes harvester per 100 ha of potatoes	121.21	61.12	-	-

Source: Own study

Despite the declaration of the majority of respondents claiming good conditions of the tractors the data in table 5, which gives the average age of tractors, doesn't give a favourable picture. The oldest tractors are in possession of the smallest farms. The average age of these tractors is 25 years and will probably stay in use for about another 8 years. The most popular among them are Ursus C-330 and C-360, but also C-355 and C-4011. However, there are also other tractors in this group such as MF and Wladimirec. The relatively low exploitation, on the level of 220 hours yearly, does not come as a surprise. Because of the simplified crop structure, high-level of human work, comparatively small acreage and no use of tractors for service outside it was not possible to reach higher level. In the next area group the average age of tractors was 18 years, and it was foreseen that it would be used for the next 11 years. Estimated value appears at about 47000 PLN with very large changeability. The most often used tractor in this group was Ursus C-360, and from more powerful tractors - Zetor, John Deere, Case, New Holland. The larger number and higher power of tractors with the lack of their utilization in services causes comparatively small yearly utilization on the level of 340 hours.

New, more valuable and stronger tractors are in possession of farms from 50.01 to 100.00 ha UAA area group. Unfortunately, they are not fully utilized. These tractors are on average 14 years old and it is predicted that they will be used for the next 9 years. Average value of tractor is almost 71000 PLN. Predominant makes are Zetor and John Deere and also Ursus and MTZ. As the scale of outside service is small it does not influence significantly the low utilization, not over 400 hours per year. The group of the largest farms is in possession of comparatively new tractors, which average age is 10 years. Indeed this is the border period which guarantees the suitable level of modernity of machine. However the owners foresee the use of this equipment for almost as many years. If brands such as Fendt, John Deere and Valtra undoubtedly create such possibility, brands like Ursus 1212 do not give such guarantee. In this group the utilization is at the level of 500 hours annually, which is higher than the national average (Muzalewski 2003).



The combine harvesters make up the next group of machinery. In relationship with the introduced crop structure the most essential are grain harvesters. In this situation the beet combine harvester and potato matter have marginal importance however the costs of utilization of these machines still exist whether the equipment is exploited or not.

Table 5. Characteristic of tractors and grain harvesters

No.	Specification	Area groups (ha UAA)			
		up to 20.00	20.01-50.00	50.01-100.00	above 100.01
1.	Tractors				
	Year of production	1982	1989	1993	1997
	Variability coefficient (%)	34.91	60.14	73.28	71.18
	Present value (PLN)	15 173.91	46 738.00	70 701.79	108 500.00
	Variability coefficient (%)	126.04	134.62	94.18	96.45
	Expected time of further usage (years)	8	11	9	9
	Variability coefficient (%)	40.34	70.13	56.86	80.14
	Yearly utilisation (hours)	220.56	339.33	389.09	500.00
	Variability coefficient (%)	93.19	58.25	71.59	31.27
2.	Cereal harvesters				
	Year of production	1987	1983	1990	1997
	Variability coefficient (%)	33.42	28.96	43.65	62.11
	Present value (PLN)	19 750.00	22 253.75	85 234.60	1 85714.29
	Variability coefficient (%)	104.62	74.46	117.16	77.84
	Expected time of further usage (years)	10	9	8	8
	Variability coefficient (%)	0.00	68.20	60.98	66.63
	Yearly utilisation (hours)	66.67	97.00	105.77	311.43
	Variability coefficient (%)	45.83	81.62	52.49	58.40

Source: Own study

Individual farms in the selected groups possess also supplementary equipment but it was not analysed in detail.

From the mechanization efficiency point of view extremely important is the form of technical equipment used. It is not always necessary for the farm to have the full set of machines. However, in case of complete machine force the farm should give outside services. It seems that the best solution from the efficiency point of view would be joint usage of the machines.

The common cooperation in the range of mechanization was not considered in the investigated group of farms. The farms normally possess their own equipment. The machine shortages are most often covered using the services of different individual farmers, more seldom from service points and large farms. The structure of service resources by the area groups is presented in table 6.

The smallest farms most often use services of grain combines and, in individual cases, beetroots and maize's sowing, picking of beetroots and transportation of manure. These farms do not give any services. The most

popular in the next area group are grain harvest service and straw baling as well as, to smaller extend, the grain sowings. These farms give the similar kind of services also outside.

Table 6. Structure of using services (%)

No.	Specification	Area groups (ha UAA)			
		up to 20.00	20.01-50.00	50.01-100.00	above 100.01
1.	Technical service point (SKR)	15.00	21.43	16.67	0.00
2.	Individual farmers	75.00	71.43	77.78	83.33
3.	Large farms	10.00	7.14	5.56	16.67

Source: Own study

From the farm group of 50.01- 100.00 ha of UAA only 5 uses services; mainly the rape, maize and sugar-beet harvesters as well as straw baling. It gives considerably more services mainly for grain harvest, straw baling and ploughing. No service among the largest farms was observed. These farms provide considerable quantities of grain combines services as well as, to smaller extend, the sugar beetroots sowing.

The analyses of the respondents' preferences related to the form of mechanization confirmed that the absolute majority declared exclusively own equipment as the favourite choice. It is prominent especially in group of the smallest farms.

Table 7. Estimated share of mechanization costs in total costs

No.	Specification	Area groups (ha UAA)			
		up to 20.00	20.01-50.00	50.01-100.00	above 100.01
1.	Share of mechanization costs (%)	41.31	37.31	42.60	41.67
2.	Variability coefficient (%)	56.45	44.39	61.64	34.64

Source: Own study

Financial effects of activities in reference to the cost of mechanization make up the efficiency. The respondents were asked about the ratio of the mechanization costs to the cost of total plant production. The results are presented in table 7. All respondents observed the ratio of about 40% independently of farm size.

## **Discussion**

The level of equipment in tractors of all area groups of farms is satisfactory. However, because of its age the machines are often technically and technologically obsolete. It applies especially to the smallest farms. This situation confirms the results of investigations led by the author in Opole Province in previous years and other results of national investigations (Szuk 2005).

The utilization age of tractors and combine harvesters is adequate only among the largest farms. In the remaining farms the utilization is low which is the result of the crop structure and small utilization of the machines outside the farm.

There is a visible relation between the area of the farm, the labour, and the level of mechanization. Commonly, both the coefficient of labour as well as the equipment in tractors and harvester-threshers, in count on 100 ha of UAA, increases together with the growth of the area.

The national investigations show, that the share of costs of mechanization in total costs of plant productions is 40-60 % (Olszewski 2000). The farmers themselves estimate the mechanization costs on average 40 %. Despite the farmers awareness of this significant level of mechanization costs they do not make any effort to increase the efficiency of mechanization through rationalizations of the forms of the equipment use. The absolute majority of farmers opts for sole and exclusive ownership of equipment.

## **References**

- Muzalewski A. 2003. Koszty eksploatacji maszyn. IBMER Warszawa. 39 p.
- Olszewski T. 2000. Jak obniżyć koszty mechanizacji w rolnictwie. Technika Rolnicza 3, pp. 4-6.
- Pawlak J. 1998. Możliwości poprawy efektywności mechanizacji rolnictwa. Zesz. Nauk. AR w Krakowie, 331, pp. 383-392.
- Szuk. T. 2005. Czynniki determinujące poziom kosztów eksploatacji sprzętu rolniczego w gospodarstwach indywidualnych. Roczn. Nauk. Rol. G, 92, 2, pp. 121-129.

## **VARIETY AND SPECIES MIXTURES OF CEREALS AS THE ALTERNATIVE FOR SUSTAINABLE AND ECOLOGICAL FARMING**

*Anna Tratwal*

*Plant Protection Institute, Department of Forecasting and Registration Pest and Diseases ,  
Poznań, POLAND*

*e-mail: A.Tratwal@ior.poznan.pl*

**Keywords:** mixtures, disease/pest reduction, sustainable agriculture

### **Introduction**

In Poland during the nineties, the use of variety (mainly in barley cultivation) and species mixtures (mainly in spring cereals) have been widely introduced into agricultural practice. The mixtures are designed particularly for the control of powdery mildew, but more general recommendations for their use are:

- broader genetic variation, a more resistant variety can be used as “physical barrier” for pathogens,
- yields of the mixtures are usually higher and more stable compared with the individual pure stands of the components,
- better overall disease performance resulting in reduced need for fungicides (lower costs and better environment impact),
- variety mixtures can be cultivated in the same agronomic and husbandry way as pure stands (Gacek et al. 1996).

Appropriate variety and species mixtures can considerably restrict the development of powdery mildew (*Blumeria graminis*) and to some extent other airborne diseases (Gacek et al.1996). Cultivar mixtures can provide functional diversity that limits pathogen and pest expansion by making use of knowledge known about interactions between hosts and their pests and pathogens to direct pathogen evolution. Indeed, one of the most powerful ways to reduce risk of resistance break-down and to still make use of defeated resistance genes is to use cereal variety and species mixtures (Finckh et al. 1999, 2000, Newton et al. 2002).

The results of field experiments designed to evaluate epidemiological and economical effects of winter wheat cultivar mixture are presented. The aim of the studies was to evaluate the possibility of reduction of powdery mildew (*Blumeria graminis* f.sp. *tritici*).

## Methods

In the two growing seasons (2005/2006, 2006/2007), experiments with winter wheat variety mixtures combined with different treatments of fungicides were carried out at two sites, namely the Plant Protection Institute Research Station Winna Góra (Wielkopolska District) and the Plant Breeding Station Bąków (Opole District).

In the experiments, two winter wheat varieties (Clever, Finezja), and their mixture, were tested on 16.5 m<sup>2</sup> plots in four replicates. On the experimental plots two different treatments with fungicides were applied:

- untreated plots (control),
- one treatment application with ½ dosage of fungicides (at the beginning of shooting - Amistar 250 SC),
- one treatment application with full dosage of fungicides (at the beginning of shooting - Amistar 250 SC),

During the vegetation season powdery mildew infection was observed 3–5 times using 1–9 scale (where 9 – fully resistant, 1 – fully susceptible).

In order to compare the disease occurrence levels on different cultivars in pure stands and on their mixture combined with different fungicide treatments the Area Under Disease Progress Curve (AUDPC) (Finckh et al. 1997) was evaluated. This is defined as follows:

$$\text{AUDPC}_i = \sum_{j=1}^{n-1} (x_j \cdot y_{ij} + x_j \frac{y_{i(j+1)} - y_{ij}}{2})$$

where:

- AUDPC<sub>i</sub> - Area Under Disease Progress Curve for i-variety (mixture),
- x<sub>j</sub> - number of days between j and j+1 observations,
- y<sub>ij</sub> - percentage of infected plant area by powdery mildew of i-variety (mixture) at the time of j-observation.

## Results and discussion

In the vegetation seasons 2005/2006 and 2006/2007 among diseases occurred on winter wheat only powdery mildew (*Blumeria graminis* f. sp. *tritici*) was observed in higher incidence. Other diseases like *Septoria nodorum*, *Puccinia triticina*, *Rhynchosporium secalis* did not have economical meaning.

In the both vegetation seasons at Bąków powdery mildew incidence was higher than at Winna Góra. (Tabs. 1-4)

Table 1. Powdery mildew (*Blumeria graminis* f. sp. *tritici*) incidence on winter wheat pure stands and mixture – Bąków, 2005/2006

Chemical treatment		Percent/reduction of area under disease progress curve		
		Finezja	Clever	Finezja/Clever
Control	AUDPC	751,6	513,6	349,2
	AUDPC reduction	-	-	40,6
full dose	AUDPC	747,3	539,7	371,7
	AUDPC reduction	-	-	42,04
half dose	AUDPC	700,1	409,5	363,5
	AUDPC reduction	-	-	25,7

Table 2. Powdery mildew (*Blumeria graminis* f. sp. *tritici*) incidence on winter wheat pure stands and mixture – Winna Góra, 2005/2006

Chemical treatment		Percent/reduction of area under disease progress curve		
		Finezja	Clever	Finezja/Clever
Control	AUDPC	337,2	326,6	127,6
	AUDPC reduction	-	-	61,3
full dose	AUDPC	211,7	230,1	129,7
	AUDPC reduction	-	-	41,8
half dose	AUDPC	152,8	129,0	103,0
	AUDPC reduction	-	-	22,2

Table 3 Powdery mildew (*Blumeria graminis* f. sp. *tritici*) incidence on winter wheat pure stands and mixture – Bąków, 2006/2007

Chemical treatment		Percent/reduction of area under disease progress curve		
		Finezja	Clever	Finezja/Clever
control	AUDPC	333,1	493,4	282,4
	AUDPC reduction	-	-	30,6
full dose	AUDPC	292,5	311,3	314,3
	AUDPC reduction	-	-	no reduction
half dose	AUDPC	400,1	416,7	270,8
	AUDPC reduction	-	-	27,8

Table 4 Powdery mildew (*Blumeria graminis* f. sp. *tritici*) incidence on winter wheat pure stands and mixture – Winna Góra, 2006/007

Chemical treatment		Percent/reduction of area under disease progress curve		
		Finezja	Clever	Finezja/Clever
control	AUDPC	260,6	171,1	168,1
	AUDPC reduction	-	-	26,0
full dose	AUDPC	185,0	160,4	126,1
	AUDPC reduction	-	-	33,3
half dose	AUDPC	320,9	191,4	196,6
	AUDPC reduction	-	-	30,8

In vegetation season 2005/06 variety Finezja at Bąków was more infected by powdery mildew than variety Clever (Tab. 1). At Winna Góra 2005/06 and at both places in growing season 2006/07 pure stands were infected by disease on the comparable level (Tabs. 2-4).

Powdery mildew reduction, thanks to growing mixtures, except one case (Baków, 2006/07, full dose of fungicide – Tab. 3), were observed in all chemical combination – Tabs. 1-4.

*Blumeria graminis* f. sp. *tritici* reductions in mixtures comparing to pure stands were observed from 20% to 60%.

## References

- Finckh M.R., Gacek E.S., Goyeau H., Lannou Ch., Merz U., Mundt C.C., Munk L., Nadziak J., Newton A.C., de Vallavieille-Poppe C., Wolfe M. S. 2000. Cereal variety and species mixtures in practice, with emphasis on disease resistance. *Agronomie* 20, pp. 813–837.
- Finckh M.R., Gacek E.S., Czembor H.J., Wolfe M.S. 1999. Host frequency and density effects on powdery mildew and yield in mixtures of barley cultivars. *Plant Pathol.* 48, pp. 807–816.
- Finckh M.R., Wolfe M.S. 1997. The use of biodiversity to restrict plant diseases and some consequences for farmers and society. pp. 199–223. In: “Ecology in Agriculture” (L.E. Jackson, ed.). Academic Press. San Diego.
- Gacek E., Czembor H.J., Nadziak J. 1996. Wpływ zróżnicowania genetycznego w mieszaninach i mieszkach zbożowych na rozwój chorób i plonowanie. *Biul. IHAR* 200, pp. 203–209.
- Newton A.C., Guy D.C., Nadziak J., Gacek E.S. 2002. The effect of inoculum pressure, germplasm selection and environment on spring barley cultivar mixtures efficacy. *Euphytica* 125, pp. 325–335

## THE RELATION BETWEEN MECHANICAL DAMAGE TO (WITLOF) CHICORY ROOTS DURING HARVESTING AND THE OCCURRENCE OF PHOMA EXIGUA VAR. EXIGUA DURING FORCING

Jürgen Vangeyte<sup>1</sup>, Jeroen Baert<sup>1</sup>, Willem Maertens<sup>1</sup>, Christel Van Ceulebroeck<sup>2</sup>,  
Wim Hubrechts<sup>2</sup>, Bart Sonck<sup>1</sup>

<sup>1</sup> Institute for Agricultural and Fisheries Research (ILVO), Technology and Food Unit,  
Agricultural Engineering, Merelbeke, BELGIUM,

e-mail: jurgen.vangeyte@ilvo.vlaanderen.be

<sup>2</sup> National Chicory Research Centre, Herent, BELGIUM,

e-mail: cvceuleb@vlaamsbrabant.be

**Keyword:** mechanical damage, witlof chicory, electronic sensor, PTR 200, harvesting

### Introduction

Witlof chicory, a prime product in Flanders, covers an area of 4500 hectares with a total value of € 43 million or 10 % of the vegetable crops. Fungal diseases, such as *Phytophthora cryptogea*, *Sclerotinia sclerotiorum*, *Sclerotinia minor* and *Phoma exigua* are an important problem. The direct annual loss is approximately 5%, apart from the ecological threat on the water quality posed by the applied fungicides. Since *Phoma* and to a lesser degree *Sclerotinia* are typically wound parasites (fig.1), (we accept as hypothesis that) their occurrence should decrease when decreasing mechanical damage.



Figure 1. Phoma infection at the root extremities

This research aims at quantifying the correlation between the mechanical damage sustained by the roots and the scale of the damage caused by *Phoma exigua* var. *exigua* (further indicated as *Phoma*) after “forcing” the harvested roots. Based on this relation, the use of crop preservatives prior to the placement of these roots in cold storage can be significantly reduced if the mechanical damage to the roots are limited.



## Material and Methods

To study the relation between the mechanical damage to chicory roots during harvesting, and the occurrence of *Phoma*, laboratory drop tests and field experiments were carried out.

### *Laboratory experiments*

A laboratory set-up was constructed to conduct the drop tests (fig. 2). To perform the drop tests without inducing an initial speed or direction or causing any damage to the roots a pneumatic piston (fig. 3) was mounted to clasp the object in different orientations and at different heights.



Figure 2. Laboratory set up

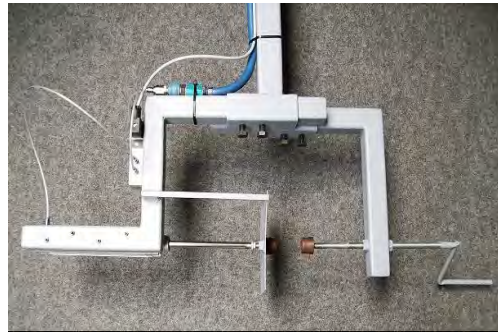

Figure 3. Detail of the root's fixation

An electronic sensor, characterized by Van Canneyt (2003), was used to register the energy value of an impact. Fifty impacts or replicates were measured for 40 combinations based on five drop heights, 0.1 m to 0.5 m with a 0.1 m interval and eight orientations.

Subsequently, for each combination, 60 manually harvested roots of the variety *Platine* were dropped one by one (fig 4) and for each of the five heights 60 roots were kept undamaged as control. Of each group of 60 roots, 30 were inoculated with a *Phoma* solution of  $1 \times 10^6$  spores/ml. The *Phoma* spores were grown on a Potato Dextrose Agar substrate (Hendrickx, 2006).

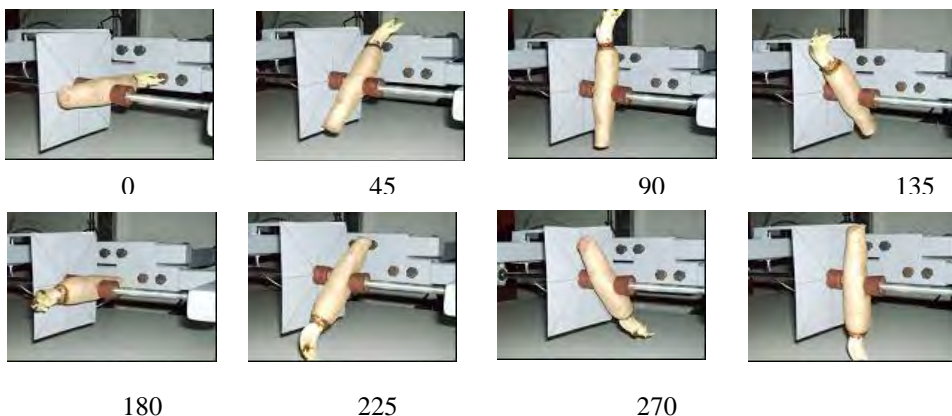

Figure 4. The drop tests at eight different positions of the endive roots

The roots were submerged in 5 l water mixed with 50 ml *Phoma* suspension of  $1 \times 10^8$ /ml spores.

### **Field experiments**

To find the relation between the energy value of impacts in the harvesters and the occurrence of *Phoma*, the overall energy values of two harvesters were measured in field experiments with the electronic sensor. Two harvesters, respectively with and without axial rolls, were adjusted in a soft and a hard setting, leading to a little and a high risk for mechanical damage. Fifty roots were harvested manually. For each machine setting fifty roots were infected with a *Phoma* solution.



Figure 5. Harvester with axial roles

### **Scoring**

All roots were stored in a climate-controlled room at a temperature of  $-1^{\circ}\text{C}$  and forced after one week. Four weeks later, all roots were evaluated for *Phoma* infection and scored. The scoring system (Locus, 2005) assigns a number on a 0 to 5 scale based on the root surface infection and the internal infection, after cutting the root lengthwise. A score 0 corresponded to no infection at all, while score 5 corresponded to a complete died off root.

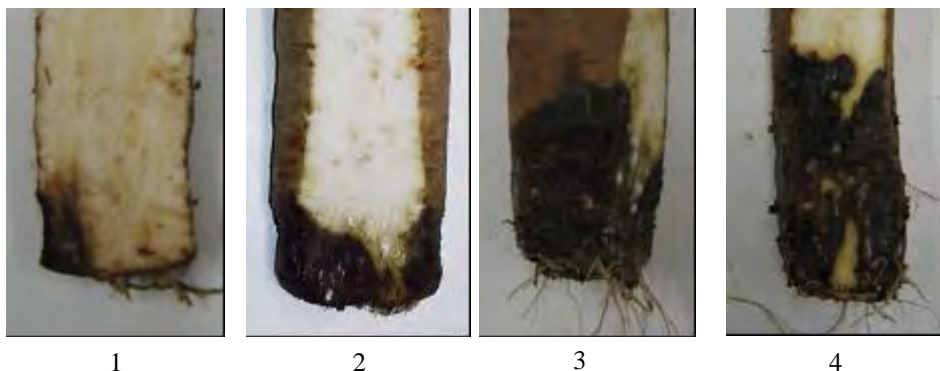

Figure 6. Visual representation of the scoring system (Locus, 2005)

Table 1. Intensity scale for infection of *Phoma exigua* (external/internal) (Locus, 2005)

Score	Damage
0	No infection, no visible symptoms
1	very (< 10 % affected root surface/ root section)
2	slight infection (10 % < affected root surface/ root section < 25 %)
3	serious infection e (25 % < affected root surface/ root section < 50 %)
4	Very serious infection (> 50 % affected root surface/ root section)
5	complete died off root

With this score a global index (eq. 1) was calculated.

$$\text{Global index (GI)} = \frac{\sum \text{score of all roots}}{\text{total number of roots}} \quad (\text{eq. 1})$$

## Results and conclusion

A high correlation ( $R = 0.9889$ ) was found between the energy value and the five drop heights. A significant difference ( $p=0.05$ ) between the orientations could not be demonstrated. There was a significant effect of the drop heights of 10, 20 and 30 cm on the Phoma index for non-inoculated roots. For 40 and 50 cm no effect of the drop height was found. For roots inoculated with Phoma the GI was significantly higher at 20 and 30 cm compared to 10 cm, whereas at 40 and 50 cm the GI was significantly lower compared to the GI at 20 and 30 cm. Field measurements showed no significant difference ( $p = 0.05$ ) in Phoma infection between the soft and the hard machine settings (table 2). The degree of infection of the manually harvested roots significantly varied from the mechanically harvested root. GIs between inoculated and non-inoculated roots showed a clear effect of the inoculation method.

Table 2. Evaluation of the *Phoma* infection of the field experiments

Machine	setting	% Phoma infection	global index
axial rolls	hard	58,33	0,75
		61,54	0,73
	soft	72,73	0,91
		65,91	0,91
manual		4,26	0,04
		9,80	0,10
No axial rolls	hard	83,33	0,96
		94,44	0,98
	soft	89,66	0,97
		91,07	1,13
manual		3,92	0,04
		12,96	0,15

The results proved that, although the inoculation method is effective, no clear effect of the degree mechanical damage on Phoma infection was found. For the laboratory test, the applied mechanical damage was likely too low or season influences exceeded the effect of mechanical damage. The field experiments showed that the harvesting machines increase Phoma infection compared to manually harvested roots but no difference between machine settings was detected. The damage caused by cutting the roots during harvesting could be of greater influence than the damage induced by the drop test or by the harvester. Therefore, further research over more than one season is necessary.

## References

- Van Canneyt T., Tijskens E., Ramon H., Verschoore R. And Sonck B. 2003. Characterisation of a potato-shaped instrumented device. *Biosystems Engineering*, 86 (3), pp. 275-285.
- Hendrickx K. 2006. Beschadiging bij witloofwortels en het voorkomen van *Phoma exigua*. Katholieke Hogeschool Kempen. Thesis 81 pp.
- Locus, E. 2005. Beoordelen van gewasbeschermingsmiddelen voor de bestrijding van schimmelziekten. Werkinstructie, Herent, Nationale Proeftuin voor Witloof, 2005, 4 pp.
- Van Ham R. 2006. Het verband tussen mechanische schade bij witloofwortels en het optreden van *Phoma exigua* var. *exigua* tijdens de forcerie. BIOT Hogeschool Gent. Thesis 109 pp.

## **STUDY, DESIGN AND DEVELOPMENT OF A LOW-BUDGET PROTOTYPE HARVESTING MACHINE FOR ROMAN CHAMOMILE**

*Jürgen Vangeyte<sup>1</sup>, Joris Baro<sup>2</sup>, Jonas Rijckaert<sup>2</sup>, Koen Vanden Haute<sup>2</sup>, Wim D'Haese<sup>2</sup>,  
Bart Sonck<sup>1</sup>*

*<sup>1</sup>Institute for Agricultural and Fisheries Research (ILVO), Technology and Food Unit,  
Agricultural Engineering, Merelbeke, BELGIUM,  
e-mail: jurgen.vangeyte@ilvo.vlaanderen.be*

*<sup>2</sup>Katholieke Hogeschool Sint-Lieven, Departement Industrieel Ingenieur, Gent, BELGIUM*

**Keywords:** Chamomile harvester

### **Introduction**

Roman Chamomile or Garden Dog Fennel (*Chaemoemelum nobile*)(Fig. 1) is used for the production of essential oils, as an aroma in tea and is popular in aromatherapy, whose practitioners believe it to be a relaxing agent to combat stress and promote sleep. In Belgium and The Netherlands the flowers are grown in beds and the fields are rather small and irregularly shaped. Existing flower harvesters (Figs 2 & 3) are not designed for these typical conditions. These large self-propelled machines have a working width of 4 m and a capacity of 0.3 ha/h. Manual harvesting of these flowers is the most common in our regions, and is time-consuming, laborious and ergonomically unjustified.



Fig. 1. Roman



Fig. 2. Czech Chamomile



Fig.3. Slovak VZR-4

The objective of this study was to develop a prototype of harvester capable of harvesting the flowers of Roman Chamomile mechanically, taking into account the small-scale application, and that delivers a harvest quality that is equal to manually harvested flowers. The stalks of the harvested flowers cannot exceed 0.02 m. The entire flower must be harvested and is collected in receptacles and the remaining plant should not be damaged since several harvests a year take place.

## Materials and methods

In the first phase, based on other harvesting techniques, the first test set-up (Fig. 4) was developed. Most harvesting techniques use a comb to grasp the flowers. With the three-dimensional CAD program ‘Solid Works’ a comb (Fig. 5) was designed from an L- profile of 4 mm thick in which teeth were milled. The teeth were 7 mm long and were placed at 13 mm intervals, leaving 5 mm of free space between the teeth. The top of the teeth were bevelled to guide the stalks into the free space between the teeth.

To cut the stalks of the flowers two small Stanley® knives were mounted on the comb.



Fig. 4. First test set-up



Fig. 5. Detail of the comb

Figure 4 shows the comb attached to a rotating arm. The combs pivot around the arm by turning the handle and describe a circumference with an adjustable radius. The angle of the comb, in respect to the described cylindrical path, was adjustable. Since chamomile was not available at the time of testing, the tests were carried out with daisies, which are comparable with chamomile. The set-up was also tested for cutting red and yellow chrysanthemums.

In a second phase a prototype of harvester was developed. The working principle of a combine harvester was adapted to include two eccentric wheels with different diameters. These were connected with each other by means of a crank and a connecting rod. The eccentricity of the cogs makes that the crank-rod combination is at one moment in a stretched position whereas at another moment it is in a bent position. This continuously changes the angle of the crank with the cogs. The movement of the crank is passed onto the comb. Important is that both cogs turn at identical speeds. The position of the comb can be varied by giving the smaller cog a different position vis-à-vis the larger cog. In the above figure the centre of the smaller cog is situated to the right of that of the larger cog. By placing the centre of the smaller cog beneath, above or left to that of the larger cog it is possible to position the comb differently for grasping the plant.

Based on this principle two drums were designed as shown in Figure 7. The specially designed combs with knife are mounted on the outside drum.

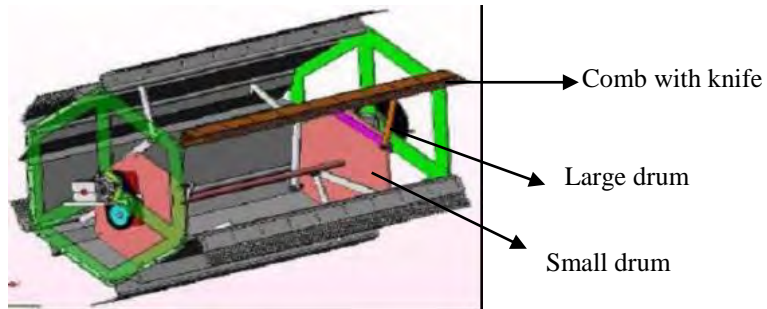

Fig. 7. Mill consisting of two drums

The flowers, cut by the comb-knife combination, were removed from the combs with a rotating brush (Fig. 8) and collected in receptacles on the conveyor belt (Fig. 9). Figure 10 shows the final three-dimensional design of the prototype.



Fig. 8. Rotating brush



Fig. 9. Conveyor belt

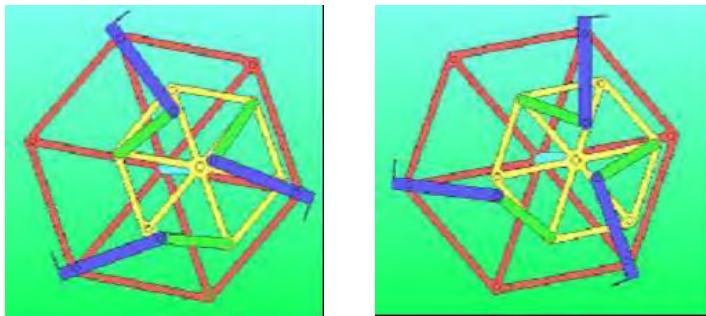

Fig. 6. Working principle of the prototype

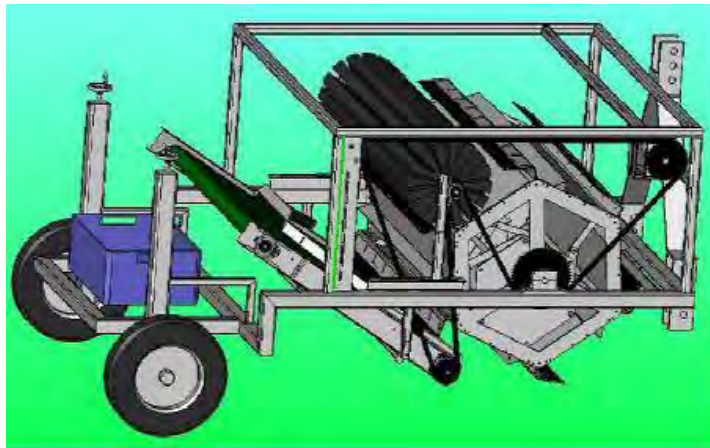

Fig. 10. Complete design of a prototype

## Results and conclusions

Figure 11 and Table 1 give respectively a visual and a measured evaluation of the test set-up for daisies. Tests with other flowers gave similar results.

Table 4. Results of the tests using daisies

	amount	percentage
Flowers without stalks	61	81
Flowers with stalks < 2cm	7	9.33
Flowers with stalks > 2cm	7	9.33
Total harvested	75	100
Leaves	9	12.00



Fig.11. Comb with cut flowers



Fig. 12. The finalised harvester

Based on the results of this set-up it was clear that a comb equipped with a knife at the underside produced promising results. The rotation speed has to be kept low e.g. 50 rpm.

Figure 12 shows the final prototype as it was built at ILVO – Section

Agricultural Engineering. The new harvester is currently subjected to a series of tests. Hitherto, one preliminary test was done and delivered promising results. Further testing and evaluation is planned in the next growing season of chamomile.



## **Acknowledgements**

The authors are indebted to Mr. Jo Neiryck and Mr. Jan Van Mullem for their technical input and their assistance in constructing this prototype. Special thanks go to Mr Frank Lunn for his help in correcting this article.

## **References**

Baro J., Rijckaert J. 2007. Studie, ontwerp en constructie van een oogstmachine voor Roomse Kamille. Katholieke Hogeschool Sint-Lieven Gent. Thesis 152 pp.

## **PRESSURE MEASUREMENTS ON CONCRETE WALLS OF FARM TRENCH SILOS**

*Annelies Van Nuffel, Jürgen Vangeyte, Jeroen Baert, Willem Maertens, Bart Sonck  
Institute for Agricultural and Fisheries Research (ILVO), Agricultural Engineering,  
Technology and Food Unit, Merelbeke, BELGIUM  
e-mail: [annelies.vannuffel@ilvo.vlaanderen.be](mailto:annelies.vannuffel@ilvo.vlaanderen.be)*

**Keywords:** horizontal pressure, trench silo, wall, load cell

### **Introduction**

Farm trench silos are mainly used for the storage of grass and maize silage. The tractor-pulled wagons filled with freshly mowed grass or chopped maize are unloaded over the whole length of the silo while driving over the forage (Figure 1). Subsequently a tractor with or without loaded wagon compresses the forage. During emptying, the vehicles exert high loads that are transferred by the forage onto the walls. A literature review (*Gruyaert et al., 2007*) showed considerable differences in measured wall pressures between authors. Therefore, more experimental measurements are required to enable constructors to design well dimensioned silos.



Figure 1. Unloading and compressing of chopped maize by a tractor-pulled wagon driving close by the silo walls

### **Methods**

A panel to measure wall pressures was developed by the Agricultural Engineering Section of ILVO (Figure 2). Ten pressure plates with a height of 0.25 m and a width of 0.75 m are crosswise divided over the front surface of a 2 m high by 2.5 m wide measurement panel. Therefore, the panel consists of eight measuring plates on the vertical middle axis (numbers 1 to 8, Figure 2) and three measuring plates on the horizontal axis at  $\pm 0.625$  m height (numbers 3, 3R and 3L, Figure 2). The two lowest pressure plates were equipped with four S-beam load cells, each with a measuring range up to 100 kg with 0.5 kg precision. All the remaining pressure plates were equipped

with four S-beam load cells of 50 kg range and 0.5 kg precision. Each measurement plate was calibrated by exerting known loads with a pneumatic piston.

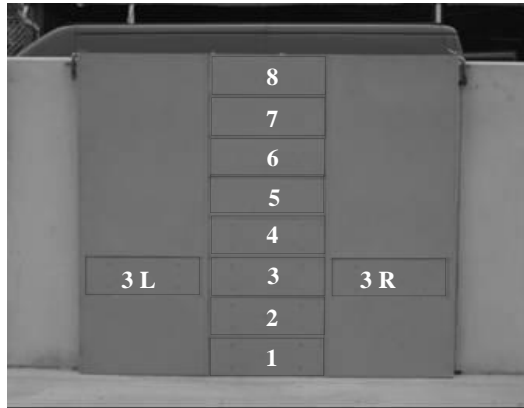

Figure 2. Measuring panel with crosswise divided pressure plates

The experiment was carried out in October 2006 during and after filling a 2 m high trench silo with chopped maize at the experimental farm of Ghent University. The measurements at different heights were used to predict the pressure distribution on the walls of the silo. During the measurements, the pressure plates detected short peak values, corresponding with the moment when a tractor or wagon passed. The wheels of these wagons passed the wall at a distance of 0.13 m. The average axle-loads amounted to 3016 kg and 7587 kg for resp. the first and second axle of the tractor and 7707 kg and 7222 kg for resp. the first and second axle of the filled wagon.

### Results and Conclusion

Figure 3 visualises the pressure ( $\text{N/m}^2$ ) on every pressure plate during the filling process of the trench silo with chopped maize. The highest peak values measured during this filling process are summarised in Table 1 for every pressure plate. Pressure peaks of more than 50 000  $\text{kN/m}^2$  were detected between 0.25 m and 0.5 m height with a maximum peak value of 54 050  $\text{kN/m}^2$ . The lowest peak pressure was found on the upper two pressure plates and they measured between 15 000  $\text{N/m}^2$  and 19 000  $\text{N/m}^2$ .

Table 1. Peak values of mass (kg) of pressure (N/m<sup>2</sup>) for every pressure plate

Pressure plate	Mass (kg)	Pressure (N/m <sup>2</sup> )
1	868	46 401
2	1011	54 050
3	724	38 684
3 L	772	41 237
3 R	723	38 657
4	689	36 791
5	686	36 677
6	770	41 156
7	345	18 584
8	298	15 931

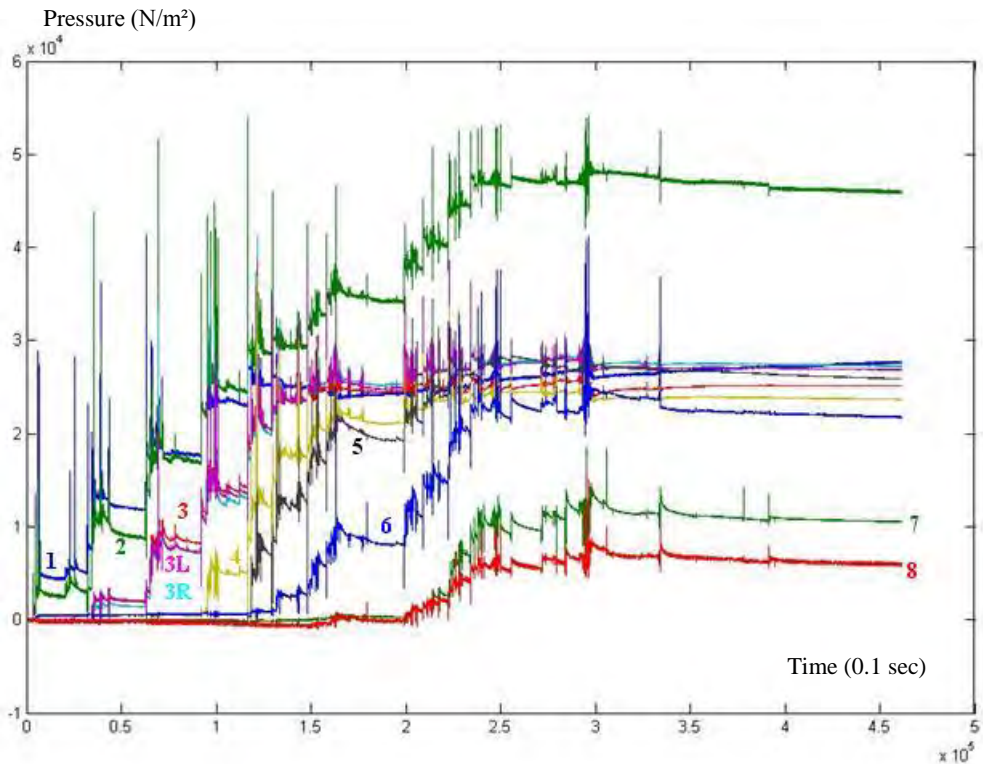

Figure 3. Pressure progress (N/m<sup>2</sup>) for every pressure plate (number) over time (0.1 sec)

Figure 4 plots the mean of the seven highest values of pressure and the mean exerted pressure on the trench silo walls after the filling process (both in N/m<sup>2</sup>) for every pressure plate.

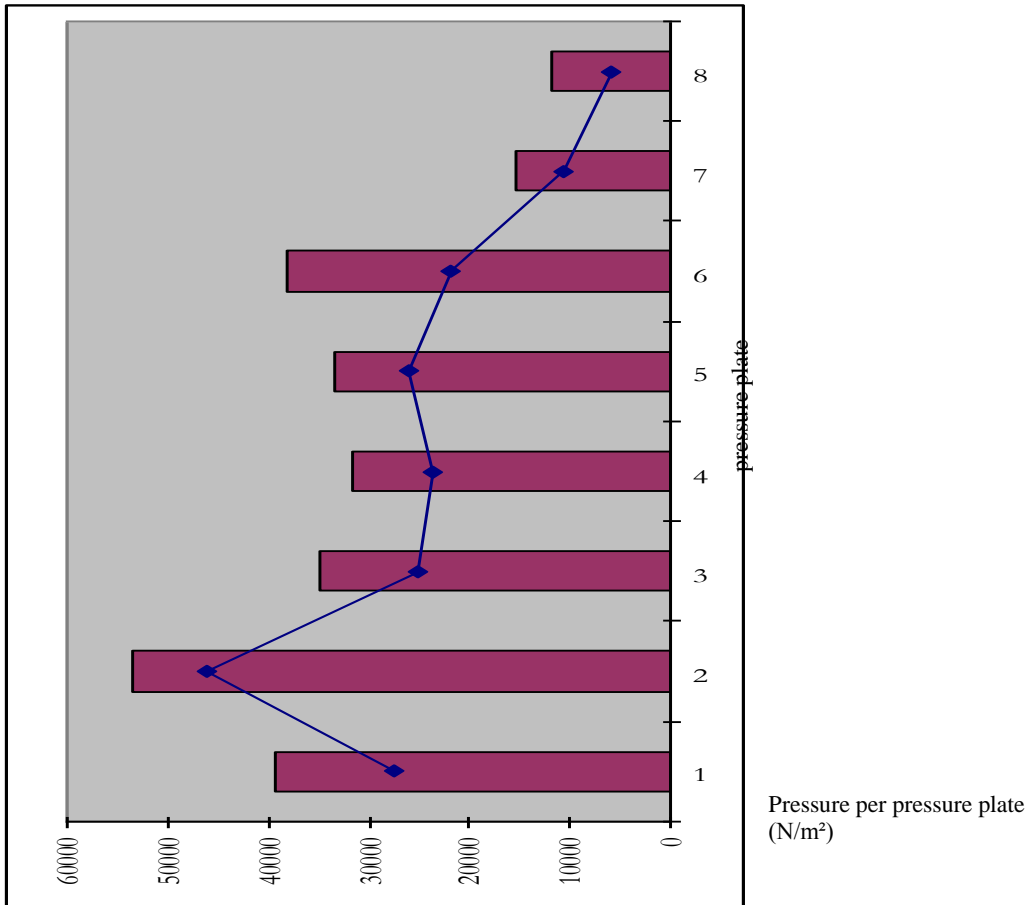

Figure 4. The mean of the seven highest values of pressure (■) and the mean exerted pressure (--) on the trench silo walls (both in N/m<sup>2</sup>)

These results show that the pressure of the vehicles' wheels compressing the chopped maize are partially transformed by the silage itself to a horizontal pressure on the silo walls. The measured pressures are much higher than expected from the literature. Consequently the literature referred to in *Gruyaert et al. (2007)* on the determination of existing loads could be out of date. As agricultural vehicles are becoming larger and heavier, loads exerted on silo walls may become larger too. To avoid cracking or even collapsing of the walls due to underestimation of the reinforcement and the dimensions of the silo walls, more research is needed under current practical conditions. Other experiments will be carried out in the near future to calculate the repeatability of our recent measurements and to elaborate a simplified load scheme for these experiments.

## **Acknowledgements**

The authors would like to thank the members of Agriprefab, a subgroup of the federation of the concrete industry (FEBE) for their contribution, support and the construction of the concrete silo.

## **References**

Gruyaert E., De Belie N., Matthys S., Van Nuffel A., Sonck B., 2007. Pressure and Deformations of Bunker Silo Walls. *Biosystems Engineering*, 97, pp. 61-74.

## **ASSESSING FARM SUSTAINABILITY: EVIDENCE FROM FLEMISH DAIRY FARMS**

*Van Passel Steven, Meul Marijke, Nevens Frank*  
*Institute for Agricultural and Fisheries Research, Social Sciences Unit, Mellebeke,*  
*BELGIUM*  
*e-mail: Steven.VanPassel@Ugent.be*

**Keyword:** farm sustainability, monitoring tool, sustainable value approach

### **Introduction**

Nowadays, sustainability is seen as a key element towards a profitable long term future for farming and rural areas. To support sustainability policy objectives, a clear framework to assess sustainability is needed. Furthermore, there is a need for empirical work measuring, explaining and evaluating contributions towards sustainability. In this paper, we will present the transition framework as a conceptual framework for the transition towards sustainable systems. To monitor the progress made, different assessment tools are needed. We will discuss two different sustainability indicator systems: an integrated monitoring tool and the sustainable value approach.

### **Conceptual framework: A transition framework for agriculture**

Transition management is a visionary, evolutionary learning process, which is progressively constructed by undertaking several steps (Martens, 2006). Figure 1 shows the different steps to achieve sustainability: (i) contextual analysis, (ii) vision development, (iii) back casting and strategy choice, (iv) action and (v) process monitoring.

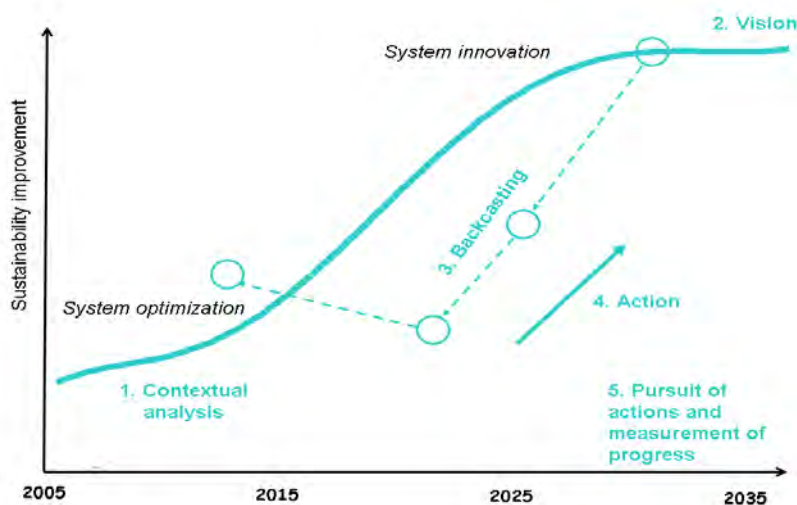

Figure 1. Conceptual framework for the transition towards sustainable systems

The first step, the contextual analysis, forms the basis of the problem outline and helps to create a first image of the desirable outcome. In the next step, this desirable image is worked out in a well-considered vision. In the third step, a strategy is developed. A strategy shows a possible path from the current situation towards the envisioned future and serves as a decision-base for taking actions. A way to achieve the desirable ideal is to use back casting. The technique of back casting can be used to determine milestones, as intermediate stop-overs in our way to achieve sustainability. In the short term existing systems are adjusted and improved (system optimization), in the long term - existing systems are changed in totally new systems with new functions (system innovation). The fourth step is to take action. Once the final goal and milestones are known, it is possible to take specific and goal-oriented actions. The fifth step in this framework is the monitoring of the progress made and thus the measurement of sustainability using indicators. More information of a transition framework for agriculture can be found in Nevens et al. (2007). In this paper we will focus on the fifth step: assessing sustainability.

There has been an explosion of activity to develop sustainable development indicators, in order to determine whether sustainable development was actually being achieved. Two major approaches can be distinguished as indicator system: (i) a set of indicators and (ii) a single, composite index or a limited amount of aggregated indicators. In other words, one could keep the indicators entirely separate, but listed or presented together within a single table or diagram (visual integration), or one could combine the indicators to yield a single index of sustainability (numerical integration). The set of indicators or visual integration is often called the framework approach, while the numerical integration methods can be described as the aggregation approach (Ekins et al., 2003).

Note that no tool for measuring sustainability is complete and none will satisfy everyone (Rees, 2000). Each approach has its pros and cons and one has to choose a particular approach depending on the specific research questions. We will present two approaches in this paper: a visual integration approach (monitoring tool) and a numerical integration approach (the sustainable value approach). Both approaches have already proved to be useful to assess the farm sustainability of Flemish dairy farms.

### **An integrated monitoring tool: visual integration of farm sustainability**

In a first step, major principles as defined by a supported vision on a sustainable (future of) agriculture in Flanders (according to the conceptual framework of Figure 1) are translated into 10 relevant themes for sustainable agricultural production, three for each of the sustainability dimensions (economic, ecological and social) and one for entrepreneurship. In a next



step, indicators are designed for each of those ten themes. For each indicator, benchmarks are defined to translate indicator values into scores between 0 (worst-case situation) and 100 (assumed sustainability). Those scores are then aggregated into an adapted radar graph (Figure 2), allowing an immediate visual interpretation of the farm's sustainability for each of the ten major themes. The more a graph segment is filled with colour, the more a farm is considered sustainable for that specific theme.

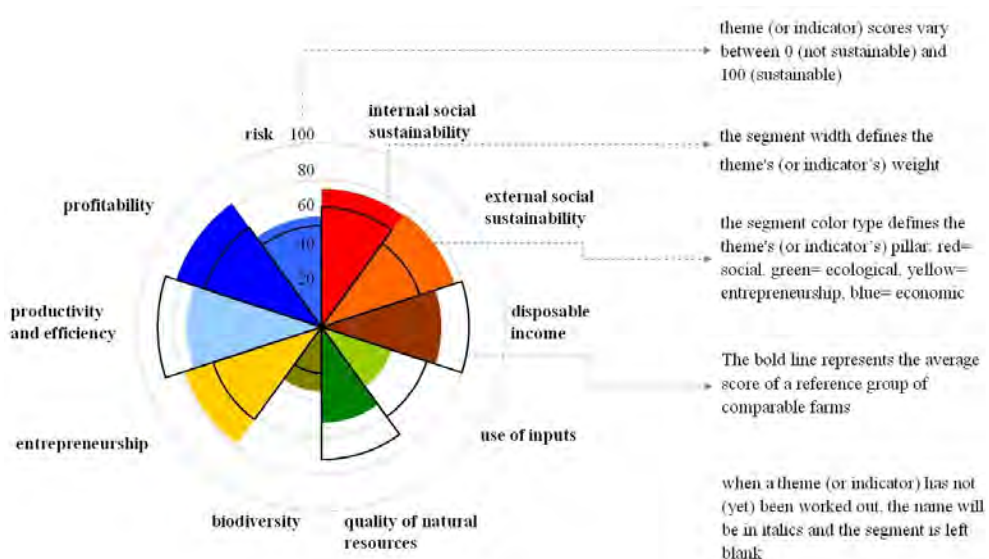

Figure 2. The integrated indicator-based sustainability monitoring instrument, presented with a legend concerning the reading and interpretation

Specific attention is paid on a user friendly and communicative design of the system by (1) providing the ability to add the average indicator scores of a group of comparable farms. This option is particularly useful for farmers who wish to communicate on their farm sustainability in a discussion group; (2) visualising the indicator weights through the width of a segment. That way, a farmer can readily distinguish which indicators are considered more or less important when evaluating the sustainability of a specific theme; (3) using a multi-level monitoring system. Level 1 gives an overview of the farm's overall sustainability. Level 2 gives an overview of the sustainability themes within a specific sustainability dimension (economic, ecological or social). In level 3, the indicator scores for a specific theme are visualised. That way, starting from an overall view of his farm's sustainability, a farmer can zoom in on the underlying themes and indicators into as much detail as desired. A detailed description of the monitoring tool can be found in Meul et al. (2007).

## Sustainable value approach: numerical integration of farm sustainability

The sustainable value approach is developed by Figge and Hahn (2004, 2005) and it shows in monetary terms the value that a company creates or destroys by the use of a set of different resources. Following steps are required to calculate the sustainable value of a company. First, the scope of the analysis needs to be determined. Second, the relevant resources to take into account (e.g., labour and land) need to be determined. Theoretically, the choice should include those resources that are critical for the sustainability performance of the company within the chosen scope. Third, the benchmark level needs to be determined. The benchmark choice reflects a normative judgement and determines the explanatory power of the results of the sustainability assessment. Table 1 shows the calculation of the sustainable value for a dairy farm with a value added of € 80 000. This company represents a dairy farm with 55 milk cows, 30 ha of land and a milk quota of 300 000 liters.

The amount used of every resource can be found in column A of Table 1. The productivity (or return on capital) of each resource can be calculated (column B). For example, the return on land is € 2667 per hectare of land (€ 80 000 / 30 ha). In the same way the productivity of the benchmark (column C) can be determined. In this example, we choose as benchmark the average return on capital of a large sample of dairy farms. In a next step, the value contributions of each resource can be calculated ( (B-C)\*A in Table 1). A positive value contribution indicates that the resource is used in a value-creating way by that company.

Table 1. Example of the calculation of the sustainable value

Resources <sup>1</sup>	Amount used by the company	Productivity (80 000/A)		Value contribution (€)
	<b>A</b>	Company <b>B</b>	Benchmark <b>C</b>	
Land	30ha	2667	2600	2010
Labour	1.00 fte <sup>2</sup>	80 000	50 000	30 000
Non- land capital	300 000 Euro	0.27	0.27	0
Energy use	1 000 000 MJ	0.08	0.07	10 000
N-surplus	6000 kg N	13.33	17.78	-26 700
		Sustainable value =		3062

<sup>1</sup>We define resources as capital forms (economic, environmental and social) or aspects derived from capital forms

<sup>2</sup>Fte: full time equivalent

To determine how much value is created by the entire bundle of resources, the sustainable value can be calculated by summing up all value contributions and by dividing this value by the number of resources. More information of

an application of the sustainable value approach can be found in Van Passel et al. (2007).

## **Conclusions and Discussion**

An important step is to move from trying to define sustainability towards developing concrete tools for measuring and promoting achievements in sustainability. In fact, this means that sustainability has to be defined in considerably narrower terms in order to establish operational rules. Hence, sustainability assessment is inevitably based on strong simplifications both of the theoretical paradigm and of the characteristics of systems of concern. Several approaches can be distinguished to integrate the sustainability dimensions: (i) a set of indicators (visual integration) and (ii) a single, composite index or a limited amount of aggregated indicators (numerical integration). We presented an example of both approaches.

The integrated monitoring tool tries to guide farmers towards a higher level of sustainability. The visual integration of relevant themes of ecological, economic and social sustainability aspects and sustainable entrepreneurship allows an immediate and integrated interpretation of a farm's overall sustainability level and gives an overview of the farm's strengths and weaknesses. The user-friendliness resulted in a monitoring tool that seems particularly interesting to be used in a discussion group of farmers to mutually compare results and exchange knowledge and expertise. Moreover, by using the monitoring system to compare farm performances of an individual farm over time, the farmer can follow-up whether management actions actually result in the aimed effect. This can make the sustainability monitor a useful management tool.

The sustainable value integrates sustainability aspects in a numerical way. The approach is extremely suitable to support decision makers in their selection of good resource users and thus to target this group. Policy makers can then decide to reward good performers or decide to help bad performers to improve their sustainable resource use. For example Van Passel et al. (2007) found that both structural and managerial characteristics have an impact on the sustainable value of Flemish dairy farms. In general, young farmers are having a higher sustainable value. Furthermore, larger farms are also having a higher sustainable value while farms that are more dependent on support payments have a lower sustainable value.

## References

- Ekins, P., Simon, S., Deutsch, L., Folke, C., De Groot, R., 2003. A framework for the practical application of the concepts of critical natural capital and strong sustainability, *Ecological Economics* 44, pp. 165-185
- Figge, F., Hahn, T. 2004. Sustainable value added – measuring corporate contributions to sustainability beyond eco-efficiency, *Ecological Economics* 48, pp. 173-187
- Figge, F. Hahn, T. 2005. The cost of sustainability capital and the creation of sustainable value by companies, *Journal of Industrial Ecology* 9(4), pp. 47-58
- Martens, P. 2006. Sustainability: science or fiction?, *Sustainability: Science, Practice and Policy* 2(1), pp. 36-41
- Meul, M., Van Passel, S., Nevens, F., Dessein, J., Rogge, E., Mulier, A. 2007. An integrated farm sustainability monitoring tool: methodology and practical application on Flemish dairy farms, submitted to *Agronomy for sustainable development*.
- Nevens, F., Dessein, J., Meul, M., Rogge, E., Verbruggen, I., Mulier, A., Van Passel, S., Lepoutre, J., Hongenaert, M. 2007. On tomorrow's grounds: development of a vision on Flemish agriculture in 2030, *Journal of Cleaner Production*, accepted in press
- Rees, W.E. 2000. Eco-footprint analysis: merits and brickbats, *Ecological Economics* 32, pp. 371-374
- Van Passel, S., Nevens, F., Mathijs, E., Van Huylenbroeck, G. 2007. Measuring farm sustainability and explaining differences in sustainable efficiency, *Ecological Economics* 62, pp. 149-161

## **STRUCTURE MODEL OF INFORMATION SYSTEM FOR IDENTIFICATION AND ANALYSIS OF LOGISTICS COSTS FOR FARMS<sup>1</sup>**

*Karol Wajszczuk*

*Agricultural University of Poznan, Department of Management and Law, Poznań, POLAND*

*e-mail: karolwaj@au.poznan.pl*

**Keyword:** logistics costs, model, farm, logistics management

### **Introduction**

In the recent years, the introduction of the concept of logistics into the enterprise management sphere is one of the more effective ways to achieve a competitive advantage (Christopher, 2000). The optimization of logistics costs is the main issue of the concept. In many sectors of economy, logistics costs have such a big share in the total production costs (on average 20-30%), that a fundamental reengineering or a certain modification of logistics processes could become the main factor of costs reduction in the enterprise (Rzymyszkiewicz, 1995; Pfohl, 2001; Skowronek, Sarjusz-Wolski, 2003). But to make an effective decision in the area, the management staff should have proper tools assisting management processes in the enterprise. Undoubtedly, one of those is a well-functioning and properly organized record-information system. Such a system should make it easier to receive information and create possibilities to conduct different analyses of enterprise activities. The results of these analyses should make it possible to use alternative solutions in the management process.

In Poland some attempts at the identification, estimation of the level and structure of logistics costs, despite the importance mentioned above still do not take a systematic and complex character of research (Blaik 2001). The main limitation on the development of such a complex approach to logistics costs is the application of traditional cost accounting (TCA) in the enterprises. The TCA system does not provide useful information because of two circumstances:

- it does not identify logistics costs in the whole system of value creation,
- it is not adapted to explain problems of modern logistics in the process and market aspects.

---

<sup>1</sup> The paper is funded by the science budget within the scientific project in 2007-2010 No:R11 009 02

### **Purpose of the model of logistics costs**

The results of some researches on farms logistics (transport, loading and unloading processes, the storage of means production and final production, diversification of production, relationships between farmer, supplier and consumer), indicate that this issue is one of the most important management problems in such enterprises. Studies conducted in selected large-area agricultural enterprises showed their high share in the total production costs (from 38% to 47%) in comparison to enterprises in sectors other than agriculture, for which this index ranges from 20% to 30%. (Wajszczuk and Wielicki, 2004; Wajszczuk, 2005). Taking the above into consideration, the aim of the paper was to present some proposal of a model system to identify and estimate of logistics costs for farms.

### **The main methodical assumptions and the structure of the model**

The basic assumption when building the model was that the system should reflect the flow of any material and information accompanying production processes. This means that the model should identify all costs, which are generated at every stage of production processes both in the farm and over the entire supply chain (from suppliers through the farm to end-buyers). Taking into consideration this fact, an integral part of the input data base for the system consists of the specially developed charts for each product, used to record all activities (events) to be connected with the manufacture of this product at all stages of the process, i.e. supply, production and distribution. Figure 1 presents the identification of logistics processes in the graph form. Due to the complexity of these processes in an agricultural enterprise, in the presented figure a certain simplification was used, as logistics processes were presented for an enterprise with one business centre. For multi-units enterprise additionally passages between objects would have to be included. Each action will be ascribed a specific process index on the individual product chart. Thanks to this in further calculations it is possible to aggregate properly logistics activities according to the adopted range of logistics costs.

## Supply chain at farm level

## Logistics processes

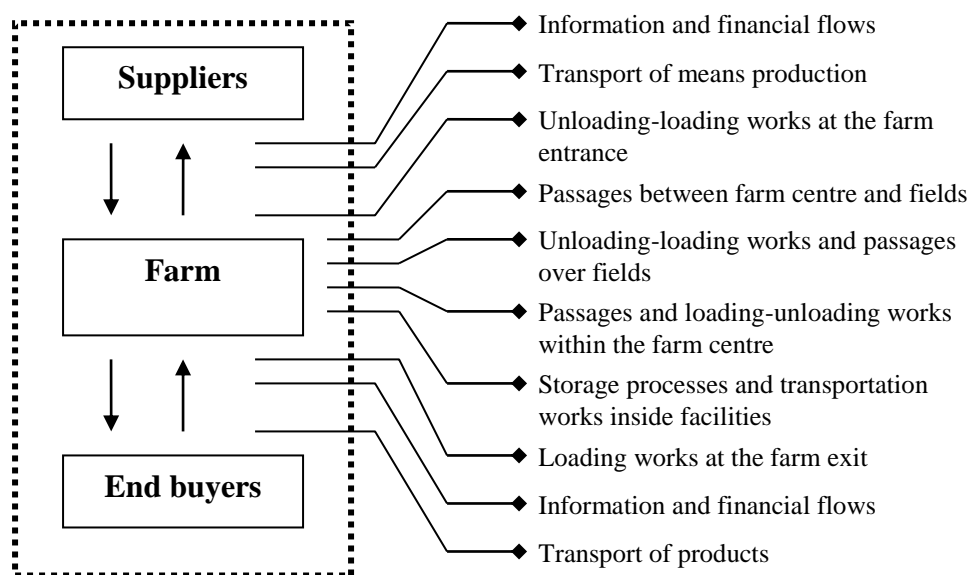

Figure 1. Logistics processes in an agricultural enterprise

Source: Author's study.

This makes it possible to define indexes of logistics costs (in PLN/ha) for each final product, as well as to determine the level of one of the basic indexes of logistics costs for an enterprise, i.e. the share of these costs in total production costs (Nowicka-Skowron 2000; Twaróg 2003). Taking into account the process aspect of the proposed model to estimate logistics costs, a costs section following three main basic elements of logistics processes will be used in the system:

- costs of physical flow of materials,
- inventory costs,
- costs of information processes

So, in the proposed model logistics costs will be calculated as follows:

$$C_l = C_{fpm} + C_z + C_{pi} \quad (1)$$

where:

$$C_{fpm} = C_a + C_{dz} + C_{pr} + C_{mpe} + C_{zut} + C_{infpm} \quad (2)$$

$$C_z = C_{ad} + C_{pr} + C_u + C_k + C_{inz} \quad (3)$$

$$C_{pi} = C_{pr} + C_{me} + C_a + C_{ut} \quad (4)$$

Individual groups of logistics costs ( $C_l$ ) include:

a) costs of physical material flows ( $C_{fpm}$ ) :

- costs of depreciation of fixed assets engaged in logistics processes ( $C_a$ ),
- costs of rent (rent for store place, garages, umbrella roofs, service roads) ( $C_{dz}$ ),
- costs of labour of staff engaged in processes of physical material flow ( $C_{pr}$ ),
- costs of material, fuel and energy ( $C_{mpe}$ ),
- costs of external transportation services ( $C_{zut}$ ),
- other costs (taxes and insurance of transport equipment, repairs and maintenance of equipment) ( $C_{infpm}$ ).

b) costs of stocks ( $C_z$ ):

- costs of depreciation or rent of storage facilities ( $C_{ad}$ ),
- costs of labour of store-keepers ( $C_{pr}$ ),
- costs of losses ( $C_u$ ), (stock obsolescence, losses during evaporation, pests, diseases),
- costs of capital frozen in stocks
- other costs (costs of storage insurance; costs of energy;) ( $C_{inz}$ ).

c) costs of information processes ( $C_{pi}$ ):

- costs of labour of staff engaged in information flow ( $C_{pr}$ ),
- costs of material and energy ( $C_{me}$ ),
- costs of depreciation of information equipment ( $C_a$ ),
- cost of telecommunications services ( $C_{ut}$ ).

The structure of the model of the proposed information system for the identification and analysis of logistics costs in agricultural enterprises will be composed of three main modules. The structure of this model is presented in Fig. 2. The first module will be made up of individual data bases comprising separately input data, logistics infrastructure data, human resources data, data concerning suppliers as well as customers. The input data base will consist of individual charts for all products found at the agricultural enterprise.

The second module will contain identified logistics subsystems for individual types of products. Thanks to this it will be possible to provide individual assessments of the efficiency of each logistics subsystem.

The third module will be the identified logistics system for the entire enterprise, being the function of subsystems listed in the second module. Within this module it will be possible to assess the efficiency of operation of the entire logistics system.

The evaluation indexes of logistics processes, established in the second and third modules, can be used in a benchmark analysis. In this case it will be a



permanent comparison between processes in the farm and model ways of courses ones.

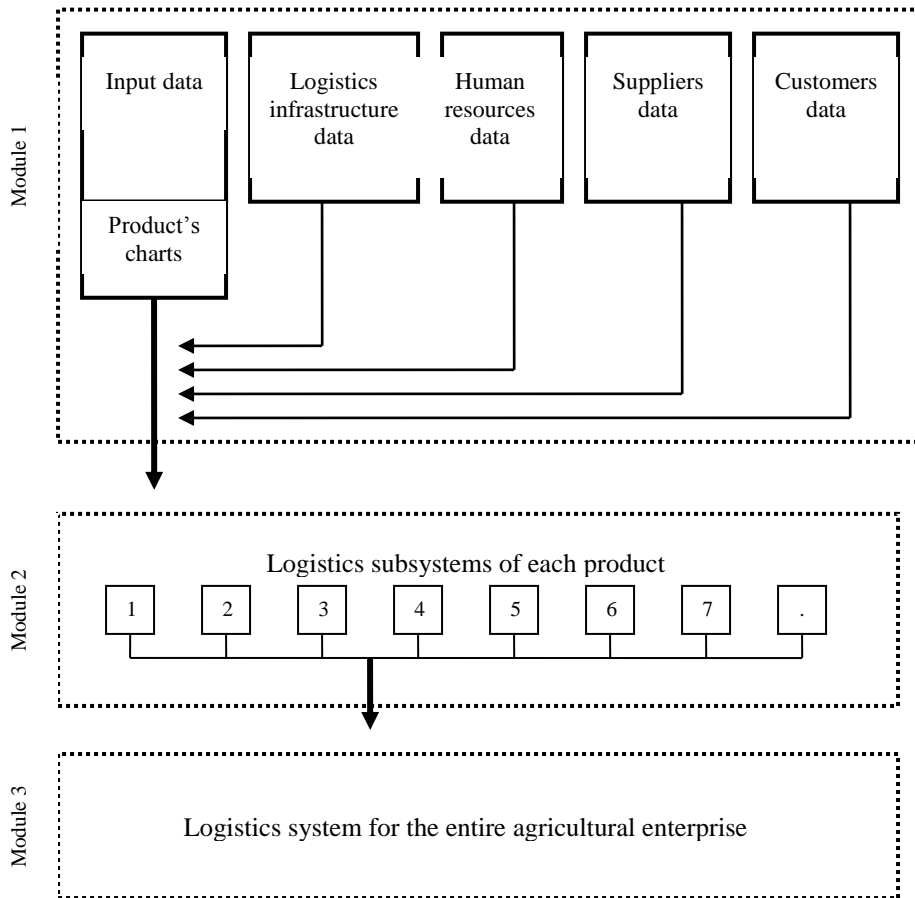

Figure 2. The structure of a model of identification and analysis of logistics costs for farms  
 Source: Author's study.

### Conclusions

Such a structure of information system model for the identification and analysis of logistics costs for agricultural enterprises will make possible to:

- estimate the level and structure of logistics costs and their influence on the whole farm activity,
- identify the diversity of costs and profitability, being a result of supplying various products and logistics services to particular consumers,

- identify changes in total costs and farm profitability caused by decisions concerning consumer and product category or distribution channels; indicate factors shaping the level and structure of logistics costs,
- characterize the influence of behaviour of participants of the supply chain (consumers and suppliers) on costs and farm profitability; point at possibilities to reduce logistics costs,
- increase quality, efficiency or rate of particular activities and whole logistics processes in a permanent or temporary way.

In view of the above such model could be a valuable tool assisting the management process in this type of enterprise.

### **References**

- Blaik P. 2001. Logistyka. PWE, pp. 303-304; 331
- Christopher M. 2000. Logistyka i zarządzanie łańcuchem dostaw. Polskie Centrum Doradztwa Logistycznego, Warszawa, pp. 4; 73
- Nowicka-Skowron M. 2000. Efektywność systemów logistycznych. PWE, Warszawa, pp. 88-90;
- Pfohl H.Ch. 2001. Systemy logistyczne. Podstawy organizacji i zarządzania. ILiM, Poznań, pp. 52-56
- Rzymyszkiewicz E. 1995. Transportochłonność w działalności logistycznej przedsiębiorstw. Logistyka 2/1995, pp. 70-72
- Skowronek C., Sarjusz-Wolski Z. 2003. Logistyka w przedsiębiorstwie. PWE, Warszawa, pp. 232; 239; 263-264
- Twaróg J. 2003. Koszty logistyki przedsiębiorstw. IliM, Poznań, :26-28
- Wajszczuk K., Wielicki W. 2004. The level and structure of logistics costs in great area agricultural enterprises. Roczn. AR Pozn., CCCLIX, Ekon.3, pp.195-203.
- Wajszczuk K. 2005. Logistics costs analysis as an assisting tool to achieve competitive advantage for agricultural enterprises. XI<sup>th</sup> International Congress of the EAAE “The Future of Rural Europe in the Global Agri-Food System” Copenhagen, Denmark: August 24-27, Paper published on CD and on website: [www.eaae2005.dk/scientificprogramme.htm](http://www.eaae2005.dk/scientificprogramme.htm)

## **INDICATING AN OPTIMAL TIME OF *OULEMA* SPP. CHEMICAL CONTROL ON CEREALS**

*Felicyta Walczak*

*Plant Protection Institute, Department of Forecasting and Registration Pest and Diseases,  
Poznań, POLAND*

*e-mail: F.Walczak@ior.poznan.pl*

**Keywords:** warning system, cereals, leaf beetles, pests

### **Abstract**

Commonly occurring in numerous countries cereal leaf beetles are pests of economic significance to cereal crops. In Poland two species that are morphologically different *Oulema melanopus* and *Oulema gallaeciana* from the *Chrysomelidae* family have been recorded. Every year beetles and larvae of *Oulema* spp. damage significantly leaf tissues of cereal leaves, which causes high losses in yields.

Extended duration of egg laying and larval development are the main reasons for making determination of optimum timing of leaf beetles chemical control very difficult.

For determining accurate time of leaf beetles control, five years experiment in growth chamber and three years under field conditions were performed. Two species of *Oulema* spp. were rearing in order to evaluate impact of temperature and air humidity on the length of egg incubation.

On the basis of the results obtained and the statistical analysis a mathematical model in the form of multiple regression equation was created. Model supports determining optimal time of chemical control against cereal leaf beetles.

### **Introduction**

Commonly occurring in numerous countries cereal leaf beetles are pests of economic significance to cereal crops. In Poland two species that are morphologically different *Oulema melanopus* and *Oulema gallaeciana* from the *Chrysomelidae* family have been recorded.

Nowadays, based on investigations carried out in the Wielkopolska province, it was ascertained that in this region *Oulema melanopus* is the dominant species while *Oulema gallaeciana* occurs less frequently due to low air humidity.

Every year beetles and larvae of *Oulema* spp. damage significantly leaf tissues of cereal leaves, which causes high losses in yields (Walczak 1999, Walczak i wsp. 1999).

Extended duration of egg laying and larval development are the main reasons for making determination of optimum timing of leaf beetles chemical control

very difficult. It frequently results in an incorrect decision by cereal producers that often cannot define the optimum timing of chemical treatment and perform chemical application when leaf beetle larvae have already damaged considerable part of the assimilation leaf area.

Mass brood of larvae from mass laid eggs occurs at the same time what an appearance of larvae of about 4 mm length of both species of *Oulema* spp. that develop from freshly laid eggs. This time indicate an optimal term of cereal leaf beetle control (Bubniewicz et al. 1993; Walczak 2002; Zalecenia ochrony roślin na lata 2006/2007, 2006).

## Methods

For determining accurate time of cereal leaf beetles control, five years experiment in growth chamber and three years under field conditions were performed. Two species of *Oulema* spp. were rearing in order to evaluate impact of temperature and air humidity on the length of egg incubation.

Two-factorial experiment was carried out in the growth chamber during the same growing season as field observations, to eliminate the effect of additional factors. Number of species it means two species *O. gallaeciana* and *O. melanopus* was the first factor and three different temperatures: 16°C (sixteen centigrade), 20°C (twenty centigrade), 25°C (twenty five centigrade) was the second one.

The other parameters were maintained as follows: relative air humidity of ca. 60% (about sixty percent); illumination of 53 000 (fifty three thousands) lux, provided by lamp usually used for experiments in agriculture; night time of 6 h (six hours) as in May.

In the years 1999-2001 *Oulema* spp. were reared under the field conditions in net cages placed on winter wheat plants grown at the Plant Protection Institute Research Station Winna Góra. The MetPole system recorded meteorological data (mean, daily air temperature and mean, daily relative air humidity).

Every year, in spring, adults were collected using an entomological sweeping net and identified in laboratory to species as: *O. gallaeciana* and *O. melanopus*. Only mating pairs were selected for further study to ensure that females would lay eggs.

The insects were placed either on winter wheat plants, cultivar Korweta growing in pots that were laid in the growth chamber - controlled environment or on plants growing in the cages - field conditions.

Number of days in development of both species of *Oulema* spp. from freshly laid eggs until larvae hatched – it means eggs incubation was observed.

## Results

In the growth chamber 588 both species eggs incubation was observed (Table 1).

Table 1. Number of observed eggs in phytotrone in 1997-2001

Year	<i>Oulema gallaeciana</i>			<i>Oulema melanopus</i>			<i>Oulema</i> spp.
	Development conditions			Development conditions			
	16°C	20°C	25°C	16°C	20°C	25°C	
1997		23			21		44
1998		38			72		110
1999	26		21	18		23	88
2000	40		46	62		50	198
2001		24	43		23	58	148
Sum	66	85	110	80	116	131	588
Total	261			327			

Under field conditions at the winter wheat plantations 26 individuals of *O. gallaeciana* and 23 individuals of *O. melanopus* was observed. The results collected from the growth chamber experiments were compared to the results collected from the field trials (Figure 1).

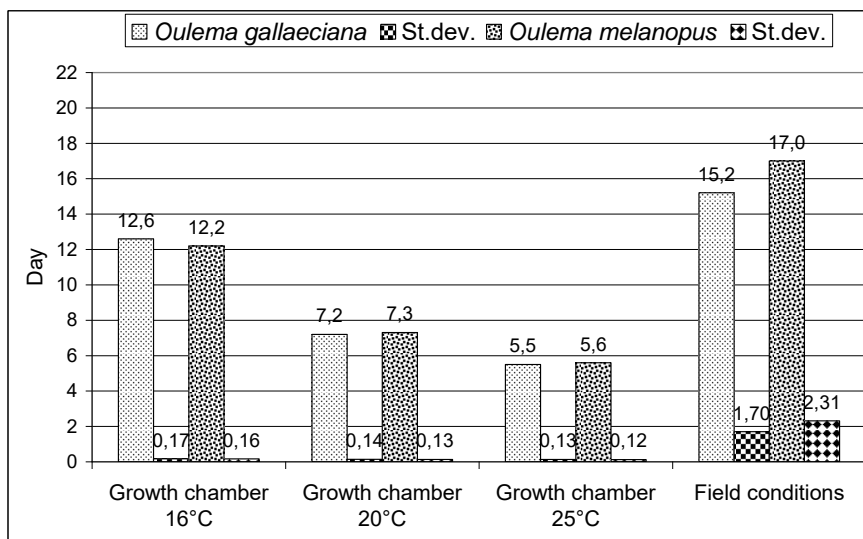

Figure 1. The average egg incubation time of *Oulema* spp. in the growth chamber and under field conditions.

In conclusion, if air temperature in the growth chamber was lower, egg incubation lasted longer, while under field conditions time of incubation period was the longest and the closest to that measured in the growth chamber at 16°C.

For eggs incubation length based on means of daily temperatures another three meteorological features were calculated; sum of heat –  $x_1$ , sum of effective temperatures –  $x_2$  and mean effective temperature –  $x_3$ . According to another research the physiological thresholds for egg incubation for *O. gallaeciana* is 10.2°C and for *O. melanopus* is 10.6°C (Ali et al. 1977). These physiological thresholds were used to calculate the sums of effective temperatures. Data of mean and daily air humidity allowed calculation of the mean air humidity –  $x_4$  for eggs incubation of *O. gallaeciana* and *O. melanopus*.

On the basis of correlation coefficient it was found that sum of heat was correlated with the sum of effective temperature and mean of effective temperature, and because of it this variable was not used in equation. Sum of effective temperature was not correlated with the mean of effective temperature.

Taking into consideration above conclusions, for multiple regression equation for eggs incubation length prognosis, three factors were used, namely:  $x_2$  – sum of effective temperatures,  $x_3$  – mean of effective temperatures,  $x_4$  – mean of air humidity.

Based on the statistical analysis the following equation was chosen :

$$\bar{y}_{(j)} = 87,4 + 0,0984x_2 - 0,949x_3 - 2,39x_4 + 0,0185x_4^2$$

$\bar{y}_{(j)}$  - prognosed number of days of eggs incubation

$x_2$  – sum of effective temperatures + five prognosed days,

$x_3$  – mean of effective temperatures

$x_4$  – mean of air humidity

$x_4^2$  – mean of air humidity

In order to check the usefulness of regression equation in years 2002-2007 the optimal time of cereal leaf beetle control was determined by two ways:

1. By signalling methods and
2. With regression equation.

Table 2. Results of the time control prognosis using regression equation

Year	Date of treatment according to:		Deviation in days
	signalling	regression equation	
2002	30.05	28.05	+2
2003	31.05	30.05	+1
2004	4.06	5.06	-1
2005	7.06	7.06	0
2006	5,06	4,06	+1
2007	28,05	30,05	-2

The time of chemical treatment in four years experiment differ only up to two days.

## CONCLUSIONS

1. Regression equation support indicating optimal time of cereal leaf beetle control.
2. Regression equation eliminates mistakes made by the producers. The biggest problem for producers is delay of chemical treatment. In six years experiment only one time the treatment was delayed only for two days.
3. The prognosis five days in advance enables to verify the term of treatment directly on the field.

## REFERENCES

- Ali A.W., Wetzel T., Heyer W. 1977. Ergebnisse von Untersuchungen über die Effektivtemperatursummem einzelner Entwicklungsstadien der Getreidehähnchen (*Lema* spp.). Archiv für Phytopathologie und Pflanzenschutz 6 (13), pp. 425-433.
- Bubniewicz P., Walczak F., Kaniuczak Z., Mrówczyński M., Widerski K. 1993. Ochrona roślin w integrowanych systemach produkcji rolniczej: Skrzypionki występujące na zbożach i ich zwalczanie. Instrukcja upowszechnieniowa. Inst. Ochr. Roślin, Poznań, 19 pp.
- Walczak F. 1999. Doskonalenie metod chemicznego zwalczania skrzypionek (*Lema* spp.) na zbożach. Prog. Plant Protection/Post. Ochr. Roślin 39 (2), pp. 400-402.
- Walczak F., Mrówczyński M., Wachowiak H. 1999. Skrzypionki zbożowe i ich zwalczanie. Ochrona Roślin nr 6, pp. 10-12.
- Walczak F. 2002. Badania podstawowe jako elementy tworzenia systemu wspomagającego podejmowanie decyzji o chemicznym zwalczaniu skrzypionek (*Oulema* spp.) na zbożach. Prog. Plant Protection/Post. Ochr. Roślin 42 (1), pp. 301-307.
- Zalecenia ochrony roślin na lata 2006/07 dotyczące zwalczania chorób, szkodników oraz chwastów roślin uprawnych. 2006. Inst. Ochr. Roślin, Poznań, cz. II:

## **MANAGEMENT OF SEWAGE SLUDGE IN SBR SEWAGE TREATMENT PLANTS**

*Zbigniew Wasąg*

*Agency for Restructuring and Modernisation of Agriculture, POLAND*

*e-mail: zbigniew.wasag@doplaty.gov.pl*

**Key words:** sewage sludge, sewage treatment plant, land reclamation

### **Introduction**

Sewage sludge is an indispensable product of the process of sewage treatment. Economic research indicates that the costs of neutralizing sewage sludge can constitute up to 2/3 of total costs of a sewage treatment plant. (Obarska-Pempkowiak, Zwara 1996; Wasąg 2001). Of the many ways in which sewage sludge can be utilized, the most widespread used is the agricultural one (Bień et. al. 1997). It is the organic substances and microelements in the sludge that make it a useful fertilizer.

Moreover, sludge can be used for energetic purposes in the processes of thermal burning or carbonating (Bień et. al. 1997). Raw sludge produced in a sewage treatment plant is dangerous from the sanitary point of view as it contains, among others, pathogenic bacteria, viruses and parasites.

Rakings are the result of sieving sewage through a grill and they are a useless type of sludge. Thus, they should be gathered in tight bags and transported to a dumping ground.

Sand, gathered at grit chambers and dehydrated in jute bags, is useless waste and should be taken to a dumping ground.

### **Research Material and Methods**

The research was carried out in a biological - mechanical sewage treatment plant of the SBR (Sequence Batch Reactor) type, with a capacity of  $365\text{m}^3\text{d}^{-1}$ . The research included an analysis of the applied sewage management and the possibilities of its improvement.

To determine the level of hydration, samples of surplus sludge were collected after the dehydration of sludge in the bag press (wet sludge weight).

The volume of removed surplus sludge was determined on the following basis: number of pressing cycles in a month, total filling of twelve bags in one pressing cycle and the Technical-Maintenance Documentation (DTR 2000), which said that one fully filled filter bag contains  $15\text{ kg}_{\text{d.s.w.}}$  after a full pressing cycle – as confirmed also by Heidrich (1994).



The result comes from this formula:

$$ON = \frac{p \cdot w \cdot 15}{d}$$

where:

- ON – surplus sludge [kg<sub>d.m.</sub>],
- p – number of pressings in one month,
- w – number of filled filter bags in one pressing cycle,
- 15 – weight of sludge [kg<sub>s.m.</sub>] in one filled filter bag,
- d – number of days.

The assessment of the composition of the sludge was based on the determination of heavy metals such as (Research procedure 1991):

- Lead according to the research procedure B – 058,
- Cadmium according to the research procedure B – 059,
- Copper according to the research procedure B – 061,
- Zink according to the research procedure B – 062.

## Results and Discussion

Due to the applied sewage treatment procedure in the SBR-type sewage treatment plant, the following (sludge) is generated: surplus sludge, rakings and Sand. Table 1 shows the volume of the generated sludge and they way in which it is utilized or neutralized. In the period from August 2000 to July 2001 80.4 m<sup>3</sup> of surplus sludge (ca. 85% hydration) was separated from the sewage, 2.4 m<sup>3</sup> of rakings and 14.7 m<sup>3</sup> of sand. On average, within one day during the research, there were generated: 0.22 m<sup>3</sup>·d<sup>-1</sup> surplus sludge, 0.007 m<sup>3</sup>·d<sup>-1</sup> rakings and 0.04 m<sup>3</sup>·d<sup>-1</sup> sand, and according to the project assumptions, respectively: 0.29 m<sup>3</sup>·d<sup>-1</sup> and 0.01m<sup>3</sup>·d<sup>-1</sup> ( 3.67 m<sup>3</sup>·year<sup>-1</sup>) (sand volume was not quoted) (Strzałka 1997). Despite a small volume of treated sewage (about 20 % of the designed capacity) (Wasąg 2001), mean volumes of the generated sludge was close to the projected volume at full load of the sewage treatment plant. According to Bernacka et al (1991) the volume of sewage sludge is about 1% of the average volume of treated sewage, with an average hydration of sludge ca. 96.5%. In the months from April to July 2001 we note an increased volume of sludge above the projected level at a full load of the plant (365 m<sup>3</sup>·d<sup>-1</sup>). A small volume of delivered sewage e.g. In November 2000 r. – 320 m<sup>3</sup>·month<sup>-1</sup> (Wasąg 2001), generates 4.8 m<sup>3</sup>·month<sup>-1</sup> surplus sludge, while in July 2001 r. the volume of delivered sewage increased to 1509 m<sup>3</sup>·month<sup>-1</sup> and 12 m<sup>3</sup>·month<sup>-1</sup> of sludge was separated. On the basis of the research results we can conclude that the cause of the increased volume

of sludge (Table 1) was a large share of delivered sewage from septic tanks reaching 70 % of the total volume of sewage in a month (Wasąg 2001).

Surplus sludge was utilized mainly environmentally to fertilize soil around the sewage treatment plant (0.85 ha) – 45.40 m<sup>3</sup>, some sludge (10 m<sup>3</sup>) was taken by Forest Superintendent's Office and the remaining part (20 m<sup>3</sup>) was still stored at the plant in this amount for further dehydration (Table 1).

Only a small amount (5 m<sup>3</sup>) was sent to a dumping ground. At the sewage treatment plant there was a spare dump, where the sludge was stored for some time (3 months) in case of a break in its collection. If, due to the results of an analysis, the sludge is not approved for environmental use (e.g. due to the presence of heavy metals), it should be then treated as useless waste and taken to a dumping ground (Sikorski, Wojarska-Maciejewska 1996/1997).

Rakings were dehydrated continually in the amount of ca. 0.4 m<sup>3</sup> (Table 1) for about three months at the sludge unit, and the remaining part (2.0 m<sup>3</sup>) was taken to a dumping ground. 14.7 m<sup>3</sup> of sand and mineral impurities were separated (Table 1) of which 4 m<sup>3</sup> was on the draining field and the remaining part was taken to a forest to be used for land levelling.

On the basis of the results from Table 2, it was concluded that the sewage sludge from the plant contained traces of studied heavy metals, only zinc reached the value of 1730 mg·kg<sup>-1</sup>, and thus close to the acceptable level for agricultural applications of sludge (2500 mg·kg<sup>-1</sup>) (Rozporządzenie MOŚZNiL 1999).

Table 1. Mean volume of sludge generated in the years 2000 – 2001, by a rural sewage treatment plant and methods of their utilisation or neutralization

Type of sludge	Unit	Mean volume /month												Total	Method of utilization or neutralization							
		2000						2001							Sludge dump – plant yard	Environmental			Dumping ground			
		VIII	IX	X	XI	XII	I	II	III	IV	V	VI	VII			Area around the plant	Forestry Commission					
Surplus sludge	[m <sup>3</sup> ] [m <sup>3</sup> ·d <sup>-1</sup> ]	1.20	1.20	3.60	4.80	7.20	7.20	7.20	7.20	7.20	7.20	9.60	9.60	9.60	9.60	9.60	12.00	80.40*	20.00	45.40	10.00	5.00
Sand	[m <sup>3</sup> ]	0.36	0.36	0.74	0.90	1.50	1.32	1.20	1.50	1.62	1.68	1.62	1.62	1.68	1.62	1.86	14.66	4.00	-	-	-	10.66
	[m <sup>3</sup> ·d <sup>-1</sup> ]	0.01	0.01	0.02	0.03	0.05	0.04	0.04	0.05	0.05	0.05	0.05	0.05	0.05	0.05	0.06	0.04	-	-	-	-	-
Rakings	[m <sup>3</sup> ] [m <sup>3</sup> ·d <sup>-1</sup> ]	0.062	0.060	0.124	0.150	0.248	0.217	0.196	0.248	0.270	0.279	0.270	0.270	0.279	0.270	0.310	2.434	0.400	-	-	-	2.034
		0.002	0.002	0.004	0.005	0.008	0.007	0.007	0.008	0.009	0.009	0.009	0.009	0.009	0.009	0.010	0.007	-	-	-	-	-

Explanations: \* - sludge hydration - about 85 %.

Table 2. The heavy metal content in sewage sludge from a rural sewage treatment plant and their acceptable levels for non-industrial use. [ $\text{mg}\cdot\text{kg}^{-1}_{\text{d.s.w.}}$ ]

Heavy Metals	Mean Values	Acceptable levels according to Rozporządzenia MOŚZNiL *			Acceptable levels according to ECC Directive **	Acceptable levels according to regulations of European countries **
		In the application of sludge				
		A	B	C		
1. Lead (Pb)	31.30	500	1000	1500	750 - 1200	200 - 1200
2. Cadmium (Cd)	2.30	10	25	50	20 - 40	3.50 - 30
3. Chromium (Cr)	-	500	1000	2500	not determined	100 - 1200
4. Copper (Cu)	130	800	1200	2000	1000 - 1750	425 - 3000
5. Nickel (Ni)	-	100	200	500	300 - 400	30 - 500
6. Mercury (Hg)	-	5	10	25	16 - 25	3.50 - 25
7. Zinc (Zn)	1730	2500	3500	5000	2500 - 4000	800 - 5000
8. Arsenic (As)	-	-	-	-	-	10 - 75
9. Cobalt (Co)	-	-	-	-	-	20 - 150

Explanations: \* - acceptable levels according to Regulation of Ministry of Agriculture, Natural Resources and Forestry (1999) \*\* Bernacka, Pawłowska (1994), A – in agriculture for land reclamation for agricultural purposes and composting, B – for land reclamation for non-agricultural purposes, C – for cultivation of plants for the production of compost and for plant hardening of land surface.

In future, it is advisable that a contract for a regular collection of sewage sludge be signed with, e.g. Forest Superintendent's Office so that when they meet quality requirements they can be used for biological purposes (e.g. forest nurseries). The acceptable levels for heavy metals that are in force in Poland (Rozporządzenie MOŚZNiL 1999) are close to the recommendations of the EEC Directive and to the regulations in European countries, and in some cases they are even lower (e.g. copper) (Table 2).

## Conclusions

1. It has been found that the cause for the increase in the volume of sludge is a large share of delivered sewage from septic tanks.
2. Sewage sludge from a rural sewage treatment plant of the SBR type, in which there were only traces of heavy metals, can be fully used in agriculture for land reclamation.

## References

- Bernacka J., Kalisz L., Jethon L., 1991. Ocena wybranych oczyszczalni ścieków. IOŚ Warszawa, p. 50.
- Bernacka J., Pawłowska L. 1994 Zagospodarowanie i wykorzystanie osadów z miejskich oczyszczalni ścieków. Wybrane problemy. Instytut Ochrony Środowiska, Warszawa.
- Bień J.B., Bień J.D., Matysiak B. i in. 1997. Zagospodarowanie i utylizacja niektórych osadów ściekowych. Wawrentowicz D. (editor) „Oczyszczanie ścieków. Nowe trendy, modernizacja istniejących oczyszczalni i gospodarka osadowa”. Materiały IX Ogólnopolskiej Konferencji Naukowo – Technicznej, Rajgród, pp. 45-53.
- Dokumentacja Techniczno – Ruchowa. 2000. Urządzenie do odwadniania osadów, system Draimad Teknobag typ 12BCAK/BCAVPK.
- Heidrich Z. 1994. Metody unieszkodliwiania małych i średnich ilości ścieków i osadów ściekowych powstających na terenach wiejskich. Politechnika Warszawska, Instytut Zaopatrzenia w Wodę i Budownictwa Wodnego, Zakład Zaopatrzenia w Wodę i Oczyszczania Ścieków, pp. 19.
- Obarska–Pempkowiak H., Zwara W. 1996. Przykłady wdrożeń technologii unieszkodliwiania osadów ściekowych z zastosowaniem ekosystemu bagienno. Zeszyty Naukowe AR we Wrocławiu, no 293, Konferencja 13, volume 2, pp. 47-56.
- Procedura badawcza. 1991. Metody analizy i oceny właściwości gleb i roślin. Katalog Instytutu Ochrony Środowiska, Warszawa, metoda: 33 (p. 155), 34 (p. 159), 35 (p. 163), 38 (p. 175),
- Rozporządzenie Ministra Ochrony Środowiska, Zasobów Naturalnych i Leśnictwa z dnia 11 sierpnia 1999: W sprawie warunków, jakie muszą być spełnione przy wykorzystywaniu osadów ściekowych na cele nieprzemysłowe. Dziennik Ustaw, vol. 72, entry 813.
- Sikorski M., Wojarska–Maciejewska I. 1996/97. Przeróbka i wykorzystanie osadów ściekowych na terenach wiejskich. Wiadomości Melioracyjne i Łąkarskie, nr 4/1996 – cz. I, pp. 164-168 i nr 1/1997 – Part. II, pp. 18-20.
- Strzałka L. 1997. Kanalizacja ściekowa i oczyszczalnia ścieków w miejscowości Tereszpol. Dokumentacja Techniczna – część technologiczna, UG Tereszpol.
- Wasąg Z. 2001. Wybrane problemy wiejskich oczyszczalni ścieków na przykładzie obiektu w Tereszpolu. Zeszyty Problemowe Postępów Nauk Rolniczych 475, pp. 173-178.

## KEYWORD INDEX

agricultural technology	57	GPS	41
agriculture machines and tractors	37	grain	135
air inclusion nozzles	67	grain maize	121
annual use	71	guiding system	41
application	17	harvesting	147
assessment	75	horizontal pressure	159
biomass	61	human resources	9
biomass potential	61	individual farm	137
cereals	177	information	17
Chamomile harvester	153	intensity of production	
chamomile harvester	153	organization	127
computer program	17	investments	21
costs	121	land reclamation	183
costs	89	leaf beetles	177
current values	37	light trap	47
cutworms	47	load cell	159
decision support software	11	logistics costs	171
deformer,	83	logistics infrastructure	79
disease/pest reduction	143	logistics management	171
droplets size	115	Lublin Province	61
droplets spectrum	67	machinery equipment	21
economic analysis	31	management of energy	31
effectiveness	89	mass occurrence	47
electronic sensor	147	mechanical damage	147
electrostatic	115	mechanization	93
energy and material inputs	127	mechanization	137
energy in agriculture	31	microwave measurement	135
energy use by crop mix	31	milking machines	71
energy use by tillage system	31	mixtures	143
energy willow	89	model	171
ergonomics	57	moisture	135
EU grants	21	monitoring	27
family farms	93	monitoring tool	165
farm	171	nozzle	115
farm	75	operation	71
farm changes	9	operation costs	37
farm mechanization	9	operational-economic indices	37
farm mechanization		organic matter balance	127
management	93	overlapping	41
farm sustainability	165	pest/disease occurrence	27
flow rate	67	pests	177
forecasting	47	pheromone trap	47
formulation of plant protection		plant protection products	101
products	101	ploughing	121

precision	41	sugar beet	11
production direction	97	sustainability of agricultural	
production system	11	production	127
profile of agricultural production	75	sustainable agriculture	17
PTR 200	147	sustainable agriculture	143
pure production	97	sustainable development	75
reduced-tillage	121	sustainable value approach	165
regional signalization	27	technical condition	137
registration of formulations in		technical equipping	97
Poland	101	technical equipping indicator	97
registration of plant protection		technical infrastructure	51
products	101	treatment plants	51
services	71	trench silo	159
sewage sludge	183	wall	159
sewage treatment plant	183	warehouse	79
sewer system	51	warning system	177
simplification	97	wastewater	51
soil	83	water supply system	51
spraying	115	witlof chicory	147
standard area of farm for parity		wood	61
income	127	work efficiency	97
straw	61	work outlays	89
stress field	83	work outlays	97
stress function	83	work safety	57
stress gradient	83		

The publication contains the summaries of presentations made at the Second International Scientific Symposium “Farm Machinery and Process Management in Sustainable Agriculture” which was held in Lublin (Poland) in October 2007.

The Symposium was organized by the Department of Machinery Exploitation and Management in Agricultural Engineering from the Faculty of Production Engineering of the Agricultural University in Lublin with co-operation of the Walloon Agricultural Research Center, Gembloux (Belgium).

The main objective of this Symposium was the exchange of research results and experiences with regard to making decisions on the techniques and technologies of production processes taking into consideration the principles of sustainable agriculture.