

Latif Onur UGUR¹

Rifat AKBIYIKLI¹

Ali ATES¹

Hakan POLAT²

¹ Duzce University, Technolgy Faculty, Departmant of Civil Engineering, Turkey

² Düzce University, Faculty of Art, Design and Architecture, Departmant of Architecture, Turkey

A SUCCESS ESTIMATE STUDY ABOUT THE ARCHITECTURE STUDENTS' CONSTRUCTION MANAGEMENT COURSE IN DUZCE UNIVERSITY

Keywords: construction management education, student success

A b s t r a c t

Construction Management (CM) or Construction Project Management (CPM) is the overall planning, coordination, and control of a construction project from beginning to completion. CM education comes in a variety of formats: formal degree programs (Two-year associate degree; four-year baccalaureate degree, masters degree, project management, operations management engineer degree, doctor of philosophy degree, postdoctoral researcher); on-the-job-training; and continuing education and professional development. CM courses are also the main lessons in civil engineering and architecture education. In this study the success of architecture department's CM course students of Duzce University has been investigated. For estimating the success level of the students a model has created. Attendance, doing homeworks, making investigations about lesson, quiz and midterm examinations' scores of the students accepted as the main factors of final successful scores for the lesson. Model's performance and relationships of the main factors with the final successful were discussed in the research.

Chapter 1

In the early 1980's, the construction industry faced increased national and international competition, stringent governmental regulations, and an environmentally conscious populace. The industry also encountered issues such as organized labor, challenges of new technologies and new materials, and construction of complex projects. These forces emphasized the value of strong engineering and management skills required for delivering high quality constructed facilities. That, in turn, added a new dimension to the profession and

led to the evolution of a group of professionals among civil engineers who practice construction management [1],[2].

Management involves four factors:

- Authority – the power to influence behavior
- Responsibility – moral and legal accountability
- Risks – chances of loss
- Rewards – things given for good service or attainment of goals [3].

Construction Management or Construction Project Management (CPM) is the overall planning, coordination, and control of a project from beginning to completion. CPM is aimed at meeting a client's requirement in order to produce a functionally and financially viable project. The construction industry is composed of five sectors: residential, commercial, heavy civil, industrial, and environmental. A construction manager holds the same responsibilities and completes the same processes in each sector. All that separates a construction manager in one sector from one in another is the knowledge of the construction site. This may include different types of equipment, materials, subcontractors, and possibly locations. Construction Management education comes in a variety of formats: formal degree programs (Two-year associate degree; four-year baccalaureate degree, masters degree, project management, operations management engineer degree, doctor of philosophy degree, postdoctoral researcher); on-the-job-training; and continuing education and professional development [4].

In order to efficiently manage large projects, construction managers must perform the following functions:

a) Planning – The ongoing process of developing the business' mission and objectives and determining how they will be accomplished. Planning includes both the broadest view of the organization, e.g., its mission, and the narrowest, e.g., a tactic for accomplishing a specific goal.

b) Organizing – Establishing the internal organizational structure of the organization. The focus is on division, coordination, and control of tasks and the flow of information within the organization. It is in this function that managers distribute authority to jobholders.

c) Staffing – Filling, and keeping filled with qualified people, all positions in the business. Recruiting, hiring, training, evaluating, and compensating are the specific activities included in the function. In the family business, staffing includes all paid and unpaid positions held by family members, including the owner/operators.

d) Directing – Influencing people's behavior through motivation, communication, group dynamics, leadership, and discipline. The purpose of

directing is to channel the behavior of all personnel to accomplish the organization's mission and objectives while simultaneously helping them accomplish their own career objectives. e) Controlling – A four-step process of establishing performance standards—based on the firm's objectives, measuring and reporting actual performance, comparing the two, and taking corrective or preventive action as necessary [3].

Tasks that a construction manager must be able to perform include: a) Analyze and interpret all types of construction drawings and documents. b) Develop conceptual programs and detail in order to calculate quantities of material, labor, and equipment needed for a project. c) Analyze financial data relative to cost budget data of construction work in the field and office. d) Apply data analysis to identify construction problems, specify goals, and execute projects, including understanding risk management and safety loss prevention. e) Utilize the critical path and Gantt bar-chart methods to organize, track, and update construction projects as necessary. f) Identify, understand, and apply the elements in construction employee relations and contract law. g) Utilize industry-standard software for estimating, planning, scheduling, and cost control. h) Understand the processes of construction disputes, claims, and project documentation. i) Obtain working knowledge of safety, health, and environmental issues [3].

For City Collage of San Francisco; Construction Management education program is comprehensive and provides students with the practical knowledge and skills required to be effective in professional environment, such as estimating and construction costing, scheduling techniques, including CPM methodology, quality control and quality assurance techniques, project control methodologies, the legal environment of the design and construction process, Building Codes, Zoning Ordinances and other regulations, written and verbal communications, technical mathematics, and computer skills [5].

Qualities that are working in the construction sector include: academic performance, teamwork skills, to have the leadership capacity; Having information technology and foreign language; To solve problems [6],[7]. Personal and managerial skills are being ignored in many construction management education [8]. students of civil engineering education is not only the technical infrastructure is also required to provide an infrastructure based on social science [9]. The scope of construction management training; students with practical experience in the use of technology for business planning and teamwork skills should be given [10].

The definition of the professional construction manager, as recently adopted, is reviewed and examined. Needed skills and knowledge implicit in the definition are identified. The current state-of-the-art in construction education is explored with specific reference to its applicability to the professional construction manager [11].

Fig. 1 explains the status of the civil and construction engineering and management curricula. Students complete key courses such as construction materials and methods, estimating, scheduling, and project management before undertaking the senior design project. Instructors use case studies, classroom examples, guest lectures, and laboratory exercises to explain the application of classroom knowledge in solving real problems. However, the current approach is often inadequate in preparing students for the on-site construction processes. This is evident from the sudden “jump” the students experience when starting their senior design project. The reasons for this “jump” are: lack of adequate experience in the dynamics and complexity of the construction site; and lack of guidance and interaction with construction experts. The senior design project—normally one semester in duration—does not completely accomplish its objective due to this missing link in the current curriculum [12].

Fig. 1. Construction Engineering and Management Education.

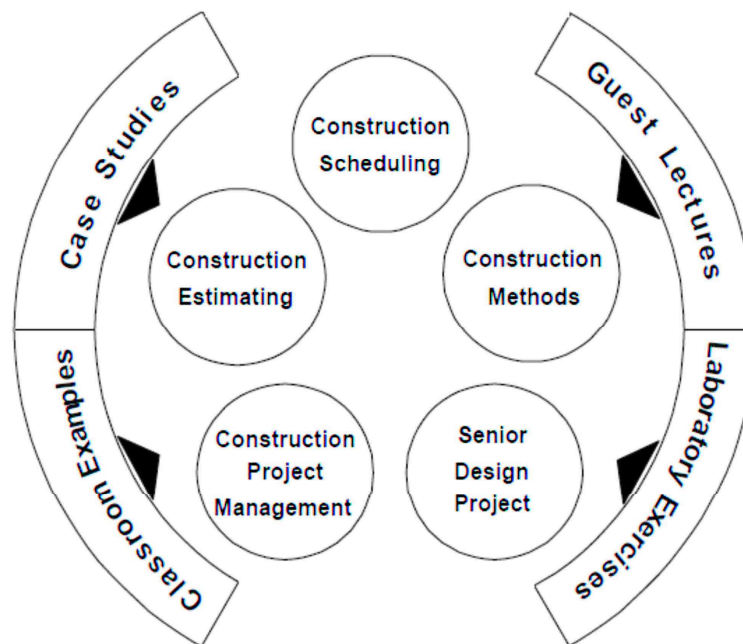

The traditional teaching methods are often not fully capable of providing students with all the skills necessary to solve the real-world problems encountered in construction [13] or conveying complex engineering knowledge effectively. The instruction methods used to convey this engineering knowledge in the majority of construction engineering and management curricula rely, for the most part, on traditional methods such as exposing students to applied science courses. Also, curricula often convey this knowledge in fragments in a series of courses [14],[15] and do not provide enough opportunities for students

to interact with construction professionals or to pool the knowledge acquired in several courses to solve real-world problems.

Knowledge workers are essential for the success of construction projects. Unfortunately, experienced construction knowledge workers are retiring and taking their decision-making skills with them, generating gaps of knowledge in the construction industry. The replacement of highly experienced project managers and other construction professionals is a laborious process for the industry, because decision-making skills are acquired slowly over many years and sometimes through the execution of costly mistakes. In addition, construction engineering and management curricula are not very helpful, as decision-making skills are difficult to teach in a traditional academic setting [16].

The complex nature of the construction industry, coupled with the challenges of global competitiveness and changing regulatory requirements, created the need for providing higher levels of education and experience of construction professionals [17].

The ABET 2000 Construction Program Criteria does not specify a minimum amount of content. The content should be consistent with the identified program objectives. Where content qualifying for other categories is also appropriate for management content, it may be counted simultaneously in both categories. Example content for this category might include

- Construction project management
- Engineering economy
- Business/technical communications
- Engineering law/legal aspects
- Business, management, and accounting
- Economics [18].

The original emphasis of construction education has been on planning, scheduling and estimating. Construction Management education emphasizes the qualitative and administrative aspects of construction such as law, resource management, and finance [19].

For the last decade, the construction industry has been rapidly and sophisticatedly changed to catch up with the current demands. Also, dramatic changes in social, economic, and environmental issues force construction management (CM) programs to produce more prepared personnel. There is no doubt that the frequent communication between industry and academia can improve the CM curriculum and program. As a result, CM students will be more adequately prepared for the industry [20].

Project management tools, methods and techniques provided the ability to communicate one on- one with trade and sub-contractors improving communication levels and working together to provide a highly successful outcome. Lessons must be presented and investigated in the professional context for which students are being educated. For students of construction management,

knowledge about environmentally considerate building must be gained as the students learn about the building development life cycle and the roles of different project stakeholders in ensuring environmental performance requirements of a the project are addressed at each project phase [21].

Turkey as well as all over the world, in the construction sector; increasing complexity of construction projects requirements needed to staff at management level is increasing rapidly. Made many scholarly works revealed that; difficulties in finding qualified staff taken on construction management, persons who wants to work in this area in areas related to building management is required to have additional training and construction project managers have to know and use serious knowledge and skills in their work areas [21].

Construction management branch which located in civil engineering and architecture education contain; construction technology, project management, cost of construction, legal, socio-political and environmental effects and other administrative issues and as a result, the profile of the human resources. In this context, construction management aims to equip the practical knowledge and to gain managerial skills. It also aims to prepare a dynamic site conditions multidisciplinary working environment as required by the construction industry [22].

Civil engineers training they received from, construction management branch to their firms' bidding, business development, proposal preparation and planning department in the field, office, or they use while working as a project engineer. The work of this task position; more bill of quantities calculations, calculation of material and labor costs, site organization, planning, procurement, contract management, market research and demand management from the covered subjects taught in fields such as construction management; construction management training of the work area that make up these issues gain competitive advantage of having well-trained engineers seem possible [22].

The scope of construction management training; students with practical experience in the use of technology for business planning and should be given basic features such as teamwork [23]. Properties are expected to be the owners of educational institutions [24];

- Students, academics, managers, to have a common vision in cooperation with industry and professional bodies,
- Being open to communication,
- There are feedback mechanisms for measurement and evaluation,
- Students will gain the ability to solve problems and not have a clear curriculum change.

Chapter 2

In this study, the success of CM course students of Duzce University Architecture Department has been investigated. For estimating the success level of the students a model has created. Attendance, doing home works, making

investigations about lesson, quiz and midterm examinations scores of the students accepted as the main factors of final successful scores for the lesson. Model's performance and relationships of the main factors with the final successful were discussed in the research. Data comes from the "Construction Management and Cost Course" of Duzce University which has given in 2015-16 spring semester. There were 27 students took this lesson and the data of the paper comes from their performance.

Construction Management and Cost Course's weekly lesson plan and course evaluation criteria's given below:

Lesson Plan: Weeks Subjects/Applications

- 1 Components of costs of buildings
- 2 Cost estimating models
- 3 Preliminary estimation methods, Vision and mission in construction firms
- 4 Latest estimation methods, Installing a construction site
- 5 Cost studies for preparation of bidding
- 6 Construction planning
- 7 Applications of planning
- 8 Direct and indirect costs of constructions
- 9 Midterm examination
- 10 Construction cost control, Construction time extension, Control and report systems in construction sites
- 11 Cash flows and making S diagrams, Occupational health and safety in construction sector
- 12 Progress and final accounts, Building inspection
- 13 Construction cost-Project time relationship and cost optimization of constructions
- 14 Reel construction cost applications in construction sector and evaluation
Final examination

Course Evaluation Criterias

- All students must keep on course min %70,
- Given all the homework; Making full and on time delivery is a necessity in order to enter the final exam,
 - A total of 60% of 40% of the midterm and final exam will be given the grade point average.

Chapter 3

The Construction Management and Cost Course applied for the architecture students. Lesson described in classroom than have been gave two home works and three investigation home works to the students. These home works occurred from similar problems which solved in the lesson. Investigation studies required

exploratory of knowledge, reasoning, inferring and solutions. Actual construction management problems discussed and typical difficulties' photographs studied in the classroom. In every lesson, an attendance form has been signed by students. Two quiz examinations, one midterm examination and a final examination have applied to the students. For the final success, all these parameters are used as ingredients and a model has been developed to analyses for the success of the students. Quiz, midterm and final examinations' questions are given below:

1. Quiz Examination Questions

Define the following terms?

1. Ram:
2. Neutral Axis:
3. Hollow:
4. Tecsimat:
5. Fret:

Please fill the places left vacant following statement?

6. Thought process;....., and comprises the steps.
7. Objects in the mind as, in the language as And in the article as are represented.
8. Despite the universal mind and the senses are reproduced relativity should not be suggesting that the sophists against individualism and relativism refused, knowledge and mental reveals the mind, abstract, conceptual, gave importance to universal knowledge.

2. Quiz Examination Questions

1. Define the following terms?

- Goat's foot:
 Barbacane:
 Blocking:
 Deterministic:
 Vertical ceramic smoke:

2. Identify direct and indirect costs, by giving examples. Direct and indirect important points by drawing graphs show the total cost of containing the costs, to examine the way?

Midterm Examination Questions

Question 1: Please provide a list of issues to be considered during the installation of the construction site. Please specify the relevant sections by drawing a sketch of the site.

Question 2: What is "80% syndrome" expressed by The firm PPS's (Project Planning System)? Explain why is it important.

Question 3: A report will be generated on site / should include typing explain the main features of the control system.

Question 4: A retaining wall of the items to be made in the construction of the manufacturing process, the units of these items, quantities and unit prices are as follows;

Name of the works	Unit	Quantity	Exp. Nr.	Unit Price (TL)
Excavation	m3	1680	Y.15.006/2B	4,55
Reinforced Pattern Works	m2	2220	21.011	19,55
Reinforcement Ø8- Ø12	ton	66	Y.23.014	1727,35
Reinforcement Ø14- Ø18	ton	72	Y.23.015	1702,65
Concreting	m3	960	Y.016.050/06	124,95
Filling Works	m3	455	14.018	6,35

	April				May				June				July				August			
Activity	1	2	3	4	1	2	3	4	1	2	3	4	1	2	3	4	1	2	3	4
Excavation	■	■			■	■			■	■										
Reinforced Pattern Works			■	■			■	■			■	■								
Reinforcement Ø8- Ø12					■	■	■	■	■	■	■	■	■	■	■	■				
Reinforcement Ø14- Ø18			■	■	■	■	■	■	■	■	■	■	■	■	■	■				
Concreting					■	■	■	■	■	■	■	■	■	■	■	■	■	■	■	■
Filling Works					■	■	■										■	■	■	■

This work is done on the basis of the delivery date specified in the contract for intermittent work schedule is given below.

7 days a week to work and normal working hours will be considering 8 hours everyday;

- a) The sum of each business day to do it escapes,
- b) Each item of work done on a daily basis the amount of stretch the average manufacturing,
- c) The amount of the progress payment will be every month,
- d) The sum of all progress (total cost of the project);
- e) Cash flow plan / forecast showing on the table to draw the S Curve.

Question 5. The following are two of the beams, reinforcement, remove the mold and concrete quantity and discovery. (There is no floor beams belong to a gym.) To be used for exposure:

-Y.016.050/06 - Pressure strength class C30/37 ready-mixed concrete pouring (124,95TL/m3)

-21.011 - Flat-topped wooden concrete and reinforced concrete formwork (19,55 TL/m2)

-Y.23.014 - \emptyset 8- \emptyset 12 mm ribbed concrete steel bar, rod cutting, bending and putting in place (1727,35TL/ton)

-Y.23.015 - \emptyset 14- \emptyset 28 mm ribbed concrete steel bar, rod cutting, bending and putting in place (1702,65TL/ton)

(Dimensions in the drawing are given in cm.)

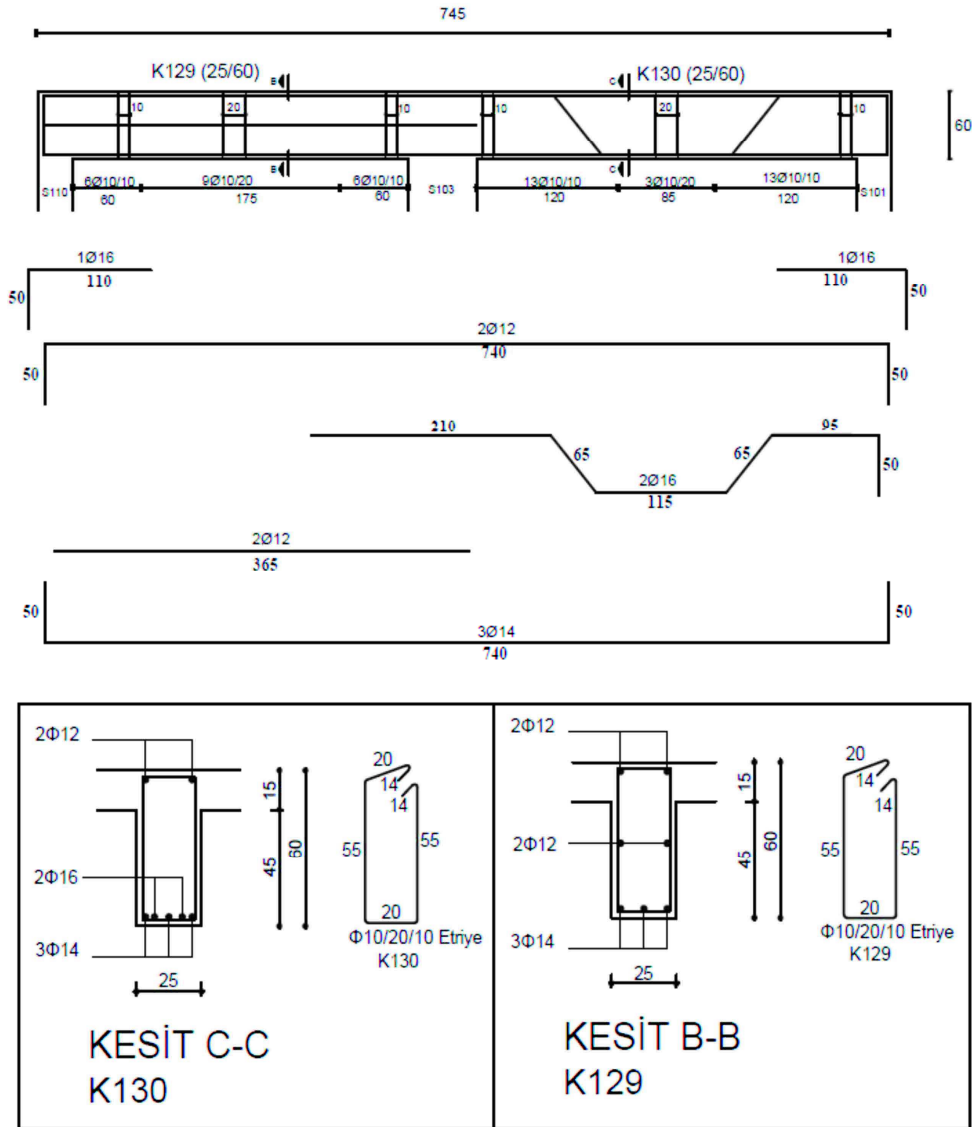

Final Examination Questions

Question 1. The following network diagrams (CPM) show the shape of the construction projects and critical path by identifying the critical activities of the network account.

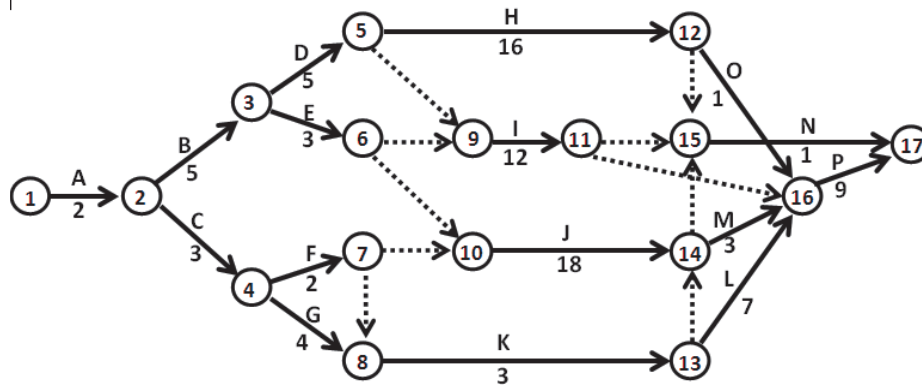

Question 2. E.C. The named Harris multinational real estate appraisal organizations issued annually between 2008-2014 date "Global Construction Cost Survey", according to the average construction cost values in Turkey a) signs with numbers how things have changed in these years. b) discuss what could be the reasons for this change.

Question 3. Carrier system of seven different buildings with similar characteristics (carcass, skeleton) total cost and costs are given in the table below. This data is based on the Functional Element Method (by regression accounts) of the total cost structure of a modeling system with the carrier.

Carrier system cost	28	35	13	46	64	39	53
Total cost	112	125	65	271	221	138	187

The cost of construction of the carrier system with similar features 76 newly made and the total cost of which can take the value? A similar structure of the carcass, which costs 197 Total costs which may be worth it? Calculate.

Question 4. The table showing the amount of the progress payment of a construction project are given below by monthly.

1.	2.	3.	4.	5.	6.	7.	8.	9.	10.	11.	12.
6	12	23	48	56	67	51	42	33	24	11	3

a) Draw a diagram of this project the cash flow of SA. b) During the period of work would be done monthly average bank interest rates by 7.6% and average monthly inflation was 4.2%; The income derived from this project (not profits!) Fourteen (14) months to the end of what is the value of your accounts?

Question 5. Below the details of the plan and the reinforcement of the concrete slab of concrete, mold and remove the reinforcement quantities and discovery.

(Only plates and ribbed and quantity of flooring is to be issued exploration and discovery is not required quantity of the main beam.)

Aşağıda planı ve donatıları verilen, D101 plak döşeme ve D102 nervürlü döşeme ait kalıp, donatı ve beton metrajı ve keşifini çıkarınız. (Sadece döşeme ve diğlere ait metraj çıkarılacak olup, kırılmalara ait metraj ve keşifler istenilmemektedir.)

-16.059/1A - Basıncı dayanım sınıfı C30/37 olan hazır beton dökülmesi
-21.017/1 - Plywood ile yapılan düz yüzeyli çelik beton ve betonarme kalıbı
-23.001/1D - F8 - F18 mm beton çelik çubuklarının bakülmesi ve yerine konulması

Pozlara ait birim fiyatlar:
-16.059/1A : 139,09 TL/m³
-21.017/1 : 28,05 TL/m²
-23.001/1D : 2507,15 TL/ton
(Çizimdeki ölçüler cm olarak verilmiştir.)

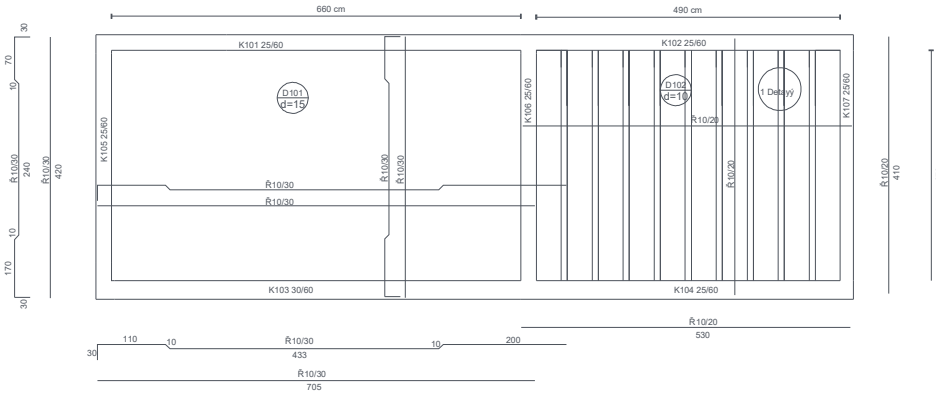
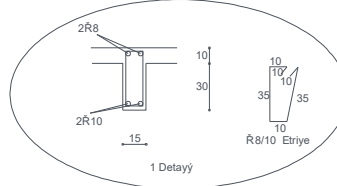

Chapter 4

A Regression model has developed for analyze of the students' success. Table 1 gives the Pearson Correlation between the parameters and success. It can be seen from this table; there are strong correlation between attendance, midterm examination and final examination with success. There is medium level correlation between first and second investigation home works. There is also a medium level correlation between first homework and first quiz examination.

Table 1. Pearson Correlation between the parameters and success

	SUCC	HW1	HW2	INV1	INV2	INV3	Q1	Q2	ME	FE	ATT
SUCC	1	0,124	0,407	0,434	0,464	0,4	0,143	0,109	0,921	0,944	0,702
HW1	0,124	1	0,597	0,167	0,12	0	0,605	-0,14	0,048	0,173	0,32
HW2	0,407	0,597	1	0,108	0,246	0,24	0,452	-0,18	0,34	0,414	0,363
INV1	0,434	0,167	0,108	1	0,657	0,474	0,255	0,231	0,413	0,399	0,276
INV2	0,464	0,12	0,246	0,657	1	0,491	-0,017	0,294	0,502	0,375	0,231
INV3	0,4	0	0,24	0,474	0,491	1	-0,104	0,162	0,352	0,392	0,267
Q1	0,143	0,605	0,452	0,255	-0,017	-0,104	1	0,052	0,083	0,177	0,291
Q2	0,109	-0,14	-0,18	0,231	0,294	0,162	0,052	1	0,099	0,104	0,058
ME	0,921	0,048	0,34	0,413	0,502	0,352	0,083	0,099	1	0,742	0,666
FE	0,944	0,173	0,414	0,399	0,375	0,392	0,177	0,104	0,742	1	0,647
ATT	0,702	0,32	0,363	0,276	0,231	0,267	0,291	0,058	0,666	0,647	1

Fig. 2 gives correlations between attendance, first quiz examination, second quiz examination with success. Determination coefficient (R^2) between attendance and success is 0,49. This means a medium level correlation between these parameters. But, quiz examinations and success has very low levels of correlation. Determination coefficient (R^2) between first quiz and success is 0,02. Like first quiz Determination coefficient (R^2) between second quiz and success is 0,01.

Fig. 2. Correlations between a) attendance b) first quiz examination c) second quiz examination with success

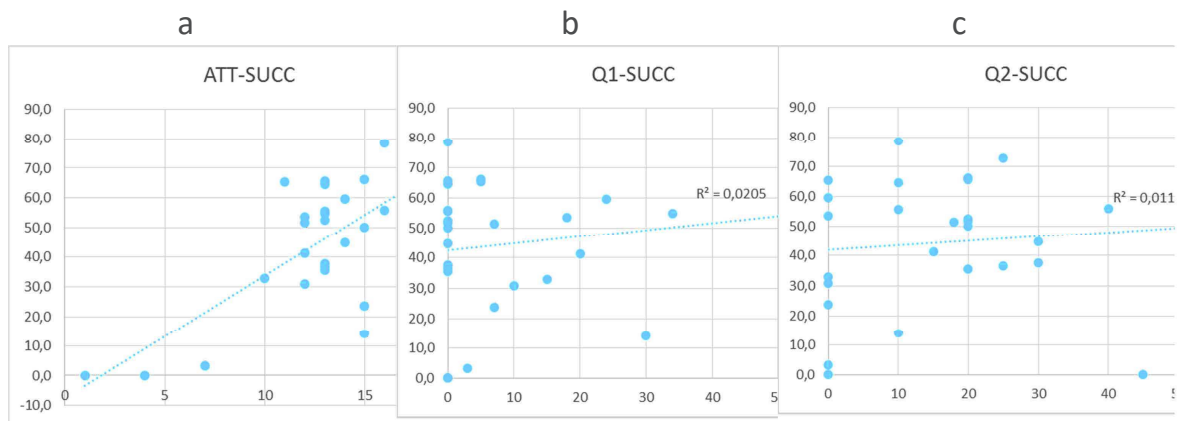

Fig. 3 gives correlations between midterm examination and final examination with success. It can be understood from this figure that there are high level correlations between midterm examination and final examination with success. Determination coefficient (R^2) between midterm examination with success is 0,846. And Determination coefficient (R^2) between final examination with success is 0,89.

Fig. 3. Correlations between a) midterm examination b) final examination with success

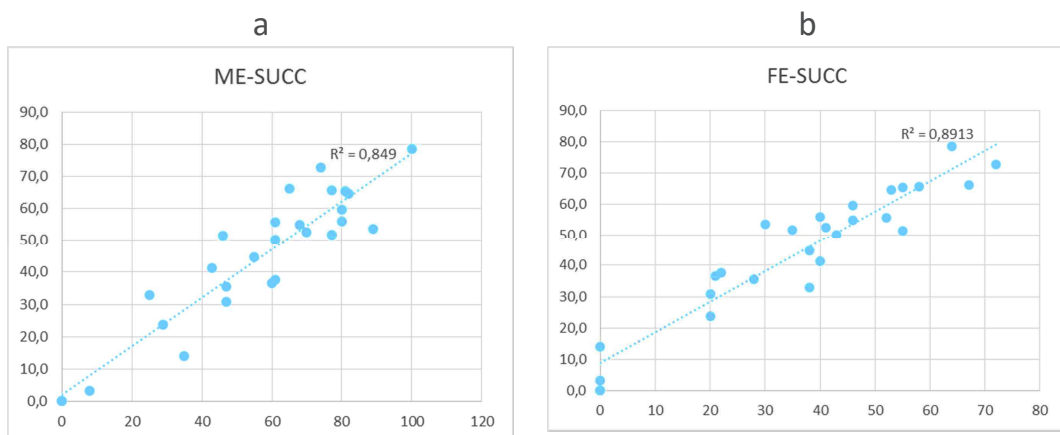

Table 2 gives the coefficients of the Regression Model of the student success. It can be understood from these coefficients; two major ingredients are midterm examination and final examination for the success of students.

Table 2. Coefficients of the Model

Model	Unstandardized Coefficients
HW1	8,16E-15
HW2	1,67E-14
INV1	3,10E-14
INV2	-4,95E-14
INV3	-1,15E-14
Q1	-8,23E-16
Q2	3,40E-16
ME	0,4
FE	0,6
ATT	5,98E-16

Summary

CM is a very large area and has lots of sub-branches. Construction project managers have to have technical and social qualifications. Undergraduate level of architecture and civil engineering educations generally executing with CM lessons in universities. The final success of a lesson, depends on a lot of parameters in architecture and civil engineering education.

In this paper; home works', investigation home works', quiz examinations', midterm examination's and final examination's effects to final success of CM course students' searched. Although CM education's spectrum and applications have a large area and have lots of application facilities; in the example of investigated in this paper, only three parameters came forward for determine the success. This finding is not means of "home works, investigations and quiz examinations are not handy tools". It's believed that the success system used for students which investigated in this essay is need to regulate. For this purpose, in the next semester, a new weighted grade system started to use. In new system there will be six quiz examinations and their weight will be %10 to final success. In addition, there will be two investigation home works. These investigation home works marks' average will use as a second midterm examination. By this way, investigations' weight, become %20 for final success. These investigations will evaluate the self-study of the students also.

References

- [1] Oglesby, C. H. (1982). Construction education: Past, present and future. *Journal of Construction Engineering and Management*, 108 (4).
- [2] Tatum, C. B. (1987). Balancing engineering and management in construction education. *Journal of Construction Engineering and Management*, 113 (2).
- [3] <https://canvas.instructure.com/courses/838884/pages/unit-5-lesson-3-construction-management>
- [4] https://en.wikipedia.org/wiki/Construction_management
- [5] https://www.ccsf.edu/en/educational-programs/career-and-technical-education/student-resources/ProgramFAQs/construction_management.html
- [6] Warszawski, A. (1984) Construction management programme. *Journal of Management in Engineering*, ASCE 110(3) pp.297-310.
- [7] Riggs, L.S. (1988) Educating Construction Managers. *Journal of Mngmnt in Engrn*, ASCE 114(2) pp.279-285.
- [8] Çıracı, M., Giritli, H., Civan, I., ve Aydemir, D. (1999) Educational Needs of Construction Management Personnel. *Engineering Education in the Third Millenium*, 28th Engineering Education Symposium, September 20-24, Istanbul, pp. 222-227.
- [9] Liu, X. ve Fang, D. (2002) Predicaments and expectations of civil engineering education in China. *European Journal of Engineering Education*, 27(2) pp.219-224.
- [10] Sears, R.H. ve Clough, G.A. (1991) *Construction Project Management*. John Wiley and Sons, Chichester.
- [11] Mark H. Jordan, Robert I. Carr, "Education for the Professional Construction Manager", *Journal of the Construction Division*, Vol. 102, No. 3, September 1976, pp. 511-519
- [12] Anil Sawhney, André Mund, and Jeremy Koczenasz, Internet-Based Interactive Construction Management Learning System, *Journal of Construction Education*, Fall 2001, Vol. 6, No. 3, pp. 124-138
- [13] AbouRizk, S. M. and Sawhney, A. (1994). Simulation and gaming in construction engineering education. *ASEE/C2E2/C2EI Conference*, Edmonton, Alberta, June 1994.
- [14] Fruchter, R. (1996). Multi-site cross-disciplinary A/E/C project-based learning. *Proceedings of the Third Congress on Computing in Civil Engineering*, Anaheim, June 1996, pp. 126- 132.

- [15] Fruchter, R. (1997). The A/E/C virtual atelier: Experience and future directions. *Proceedings of the Fourth Congress on Computing in Civil Engineering*, Philadelphia, June 1997, pp. 395- 402.
- [16] Eddy M. Rojas, Amlan Mukherjee, Modeling the Construction Management Process to Support Situational Simulations, DOI: 10.1061/(ASCE) 0887-3801 (2003) 17:4 (273)
- [17] “The challenge of the 90’s.” (1990). *Civ. Engrg.*, ASCE, 60(10), 44–53.
- [18] Osama Abudayyeh, P.E., Jeffrey Russell, P.E., David Johnston, P.E., Fellow, and James Rowings, P.E., Construction Engineering And Management Undergraduate Education
- [19] Paul S. Chinowsky and Jorge A. Vanegas, Combining Practice and Theory in Construction Education Curricula, 1996 ASEE Annual Conference Proceedings, Session 1221
- [20] Namhun Lee, Robert Ponton, A. W. “Jeff” Jeffreys, Ron Cohn, Analysis of Industry Trends for Improving Undergraduate Curriculum in Construction Management Education, 47th ASC Annual International Conference Proceedings
- [21] P.M. Graham, G.P. L. Coutts, D. Hes, What The Process Of Delivering ‘Sustainable Buildings’ Can Teach Us About Construction Management Education,
- [22] M. Talat Birgönül, İrem Dikmen, Beliz Özorhon, Zeynep Işık, İnşaat Sektörünün Yapım Yönetimi Eğitiminden Beklentileri, <http://www.imo.org.tr/resimler/ekutuphane/pdf/1558.pdf>
- [23] Sears, R.H., Clough, G.A. (1991) Construction Project Management. John Wiley and Sons, Chichester.
- [24] Miers, R.J. (2001) Critical Needs in Current Construction Management Education Practices: The Problem Solving Process as Related to the Curriculum. PhD Thesis, State University of New York, Syracuse, New York.