

STRESSES IN THE TANK SHELL WITH SHAPE DEFORMATION

Dariusz Kowalski

Metal Constructions Department, Technical University of Gdansk, Poland

ABSTRACT

In the paper are shown the results of measurements of stress state in the real tank. The tests were performed with the utilisation of electroresistant tensometry methods. The object of the tests was a vertical tank with nominal capacity of 12.000 m³ and a floating roof. The tank had been operated incessantly for almost 40 years. The shape deformation of the shell generating line was very large. This deformation fluctuated in the range from -170 to +150mm. The measurements of the stress state were used for verifying the values obtained by numerical analysis of the deformed cylindrical shell.

GENERAL FEATURES OF THE TESTED OBJECT

The tested object was an above-ground cylindrical vertical tank with a floating roof of the pontoon-membrane type. The basic dimensions of the tank are shown in fig. 1, its general view is shown in fig. 2. The joint type used in the shell is both vertical and horizontal butt welds. On the last ring of the tank shell, a sealing wind ring is fitted. It is horizontal, 850 mm wide and made of 6 mm thick steel sheet, with a channel bar 80 at its outside end.

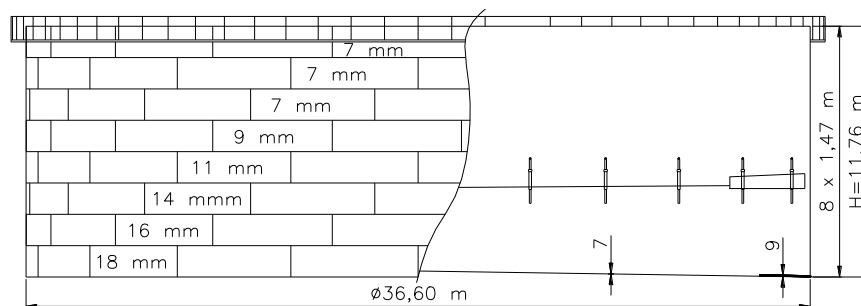

Fig. 1. Vertical section of the tested tank



Fig. 2. General view of the tank

The tank is placed on sand foundations encircled by a foundation ring made of reinforced concrete. The tested tank was constructed in the years 1961 – 63 and since 1963 it has been operated incessantly.

ASSESSMENT OF THE TANK SHELL DEFORMATION AND ITS ORIGINS

The surface of the tank shell was greatly corrugated. Its shape was deformed during the construction period, and also later, throughout almost forty years of its service life. The deformation generated during the production period includes mainly angular refraction at vertical and horizontal butt welds of the tank shell.

Another cause of deformation during the construction period is the imperfection of calculation of the perimeter of the first shell ring at the bottom rim of the tank. The deviation from the centric position of the first shell ring is of -57 to 56 mm, which gives a difference of 113 mm in the radius length already at the tank's bottom. This results in placing the next shell rings on an imperfect base. When added up, the imperfections of laying out and positioning each next ring cause an increase in the cylindrical shell deformation values.

The next cause of new deformations or an increase in the existing deformation is the process of irregular tank subsidence into the sand foundations. It is connected with the consolidation degree of the sand foundations and with the value of concentrated load of the tank shell's dead weight. The changeable level of sand cushion consolidation on the surface of the foundation can be attributed to atmospheric influence – temperature changes – and especially to freezing and thawing of the ground near the reinforced concrete ring encircling the foundations.

The settlement of the tank shell perimeter ranges from -18 to 31 mm (difference of 49 mm at the circumference of the tank). The total value of tank settlement during the tank's service life is not known due to the lack of post-construction measurements. Total tank shell deformation resulting from construction imperfections and irregular settlement reaches the values of -169 mm (deformation inside the tank) to 149 mm (outside deformation).

The existing shell deformation state was recreated on the basis of geodetic measurements, which were taken on 40 plumb-lines located uniformly on the tank's perimeter. The measurements were made on each tank shell ring on three levels (on the lower rim, on the middle rim and on the upper rim), with an additional measurement on the level of 300 mm above the tank's bottom.

In total, measurements were taken in 680 points of the empty tank. The nature of shell deformation can be seen on the enclosed selected measurement plumb-lines of the tank shell (fig. 3).

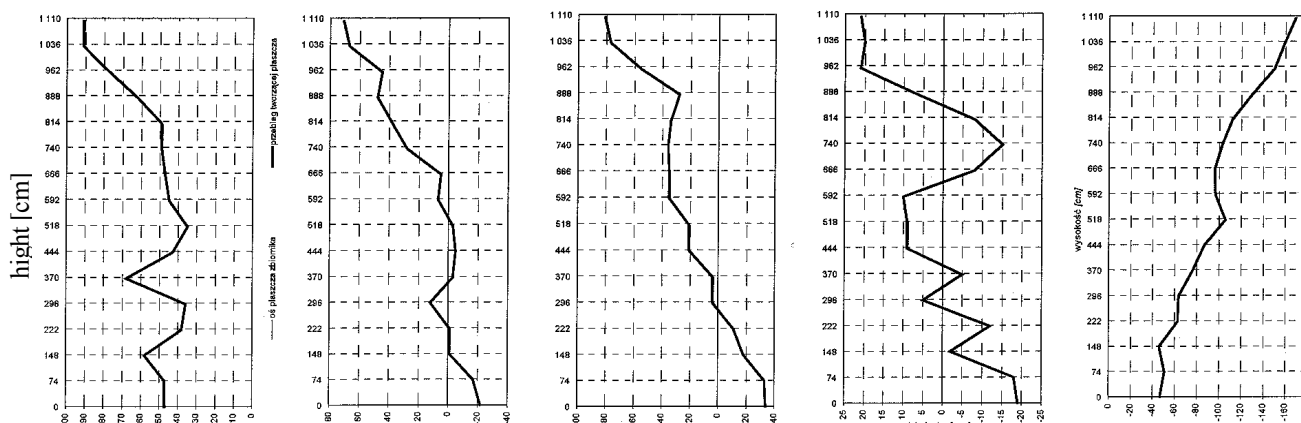

Fig. 3. Deformation at selected measurement plumb-lines of the tank shell

TESTS PREPARATION

The analysis of the tank shell deformation was carried out on the basis of information on the nature of the cylindrical shell deformation. Geodetic measurements data was used to create a computer model of the tank with the utilisation of such programmes as Robot V6 and MSC.NASTRAN, and also to create a statistic description. The analysis of the tank model with the utilisation of finished surface elements facilitated the calculation of the distribution of internal forces and stresses in the deformed shell. On the basis of this distribution, three tensometric measurement plumb-lines were planned and their location was decided upon. At this stage, a detailed plan of future measurement works was designed.

Furthermore, it was planned that three linear tensometers would be installed on each shell ring of the tank. They were fixed on the upper and lower edge of each ring 20 mm from horizontal welds and at least 150 mm from the vertical welds. Tensometers were also installed in the middle of each shell ring. In the course of installation it was

decided that the number of measurement points would be increased and thus, additional horizontal tensometers were installed on rings 5 and 6 on the vertical measurement plumb-line no 1. They were fixed on both sides of the plumb-line at 3 meters length. Single additional vertical tensometers were also fixed on each measurement plumb-line in the places of the highest angular refraction between sheets at the horizontal welds (fig. 4).

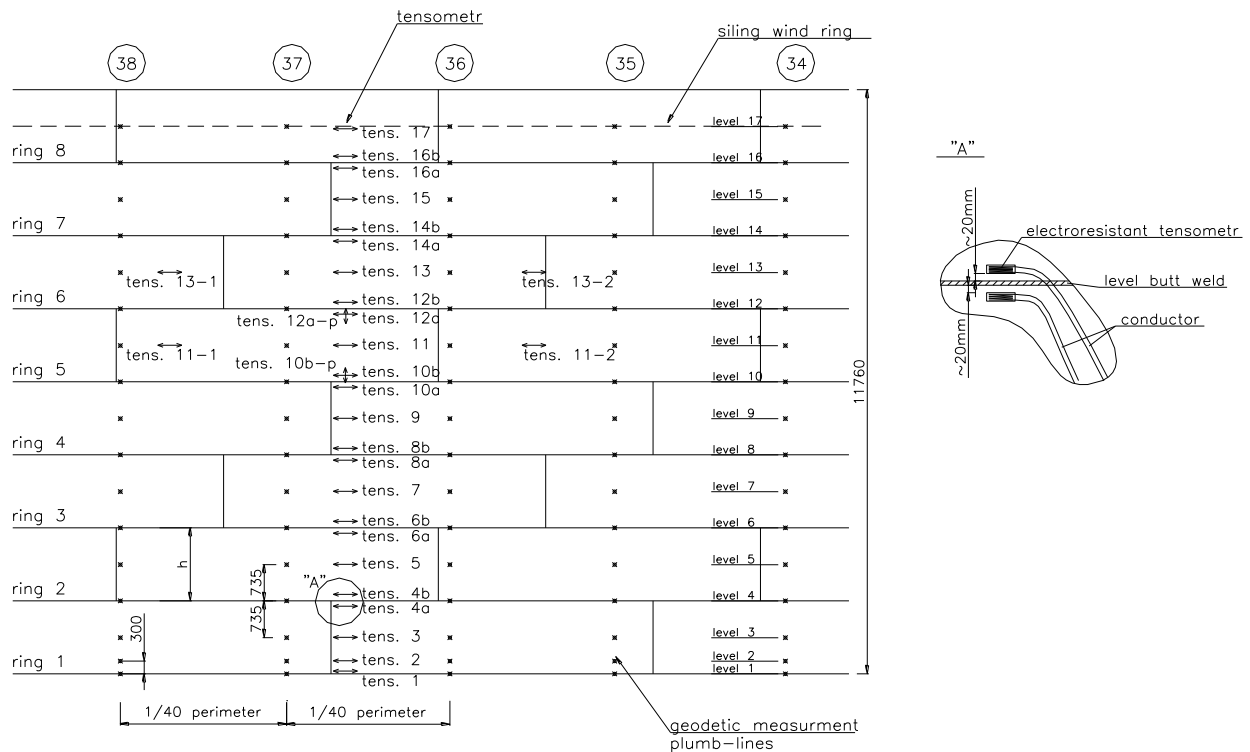

Fig. 4. Distribution of tensometers and measurement plumb-lines on the tank shell.

THE COURSE OF PERFORMED TESTS

The measurements of deformation of the steel tank shell were taken with the utilisation of electroresistant tensometric converters LY 11 6/120 which were made by Hottinger Baldwin Messtechnik company, and glued to the construction with glues made by Measurements Group. The course of the performed tests was recorded with the use of PC computers co-operating with multipoint measurement systems UPM 60 and ONIX 64. Tests were carried out using the measuring apparatus of the Bridge Department of Technical University of Gdańsk and with the participation of this department's staff.

The measurements were to be taken in two complete measurement cycles (i.e. two cycles of filling and emptying the tank), however the weather conditions – a sudden return of winter and a 20°C temperature fall as well as technical difficulties limited the works to one complete cycle and the initiation of filling in the second cycle. The values of stress in the tank shell were recorded automatically every 15 minutes. The variability of stress values recorded during the measurements is shown in fig. 5.

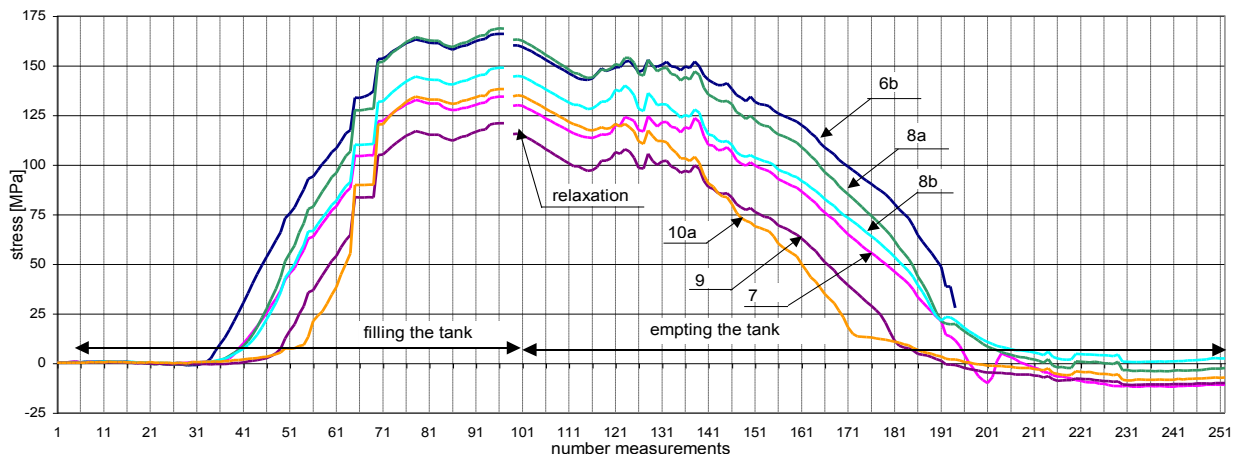

Fig. 5. Recorded variability of stress (measurement levels according to fig. 4)

MEASUREMENTS VERSUS ANALYTICAL CALCULATIONS

The tested tank is one of the most deformed objects in this group of steel constructions. Thanks to standardising the value of deformation Δ_i with the real value of thickness t_i of tank shell plates on a given level, we obtain the values of variability ranging from 3,3 to 28,3. Fig. 6 presents a detailed study of the deviations. Such imperfections result in visible eccentricities between particular elements of the tank shell rings, which leads to generating not only circumferential stretching forces in the cylindrical shell of the tank but also considerable values of vertical forces and bending moments. Fig. 7 shows an example of perturbation of circumferential stretching forces for the analysed measurement plumb-lines, with the results for the shells with imperfections and for ideal shells.

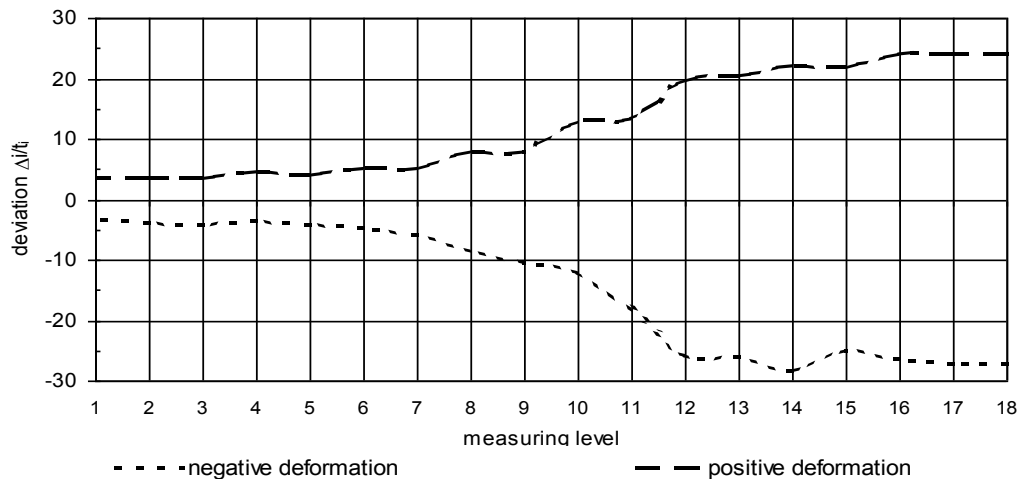

Fig. 6. Deformation standardised with the real shell plate thickness

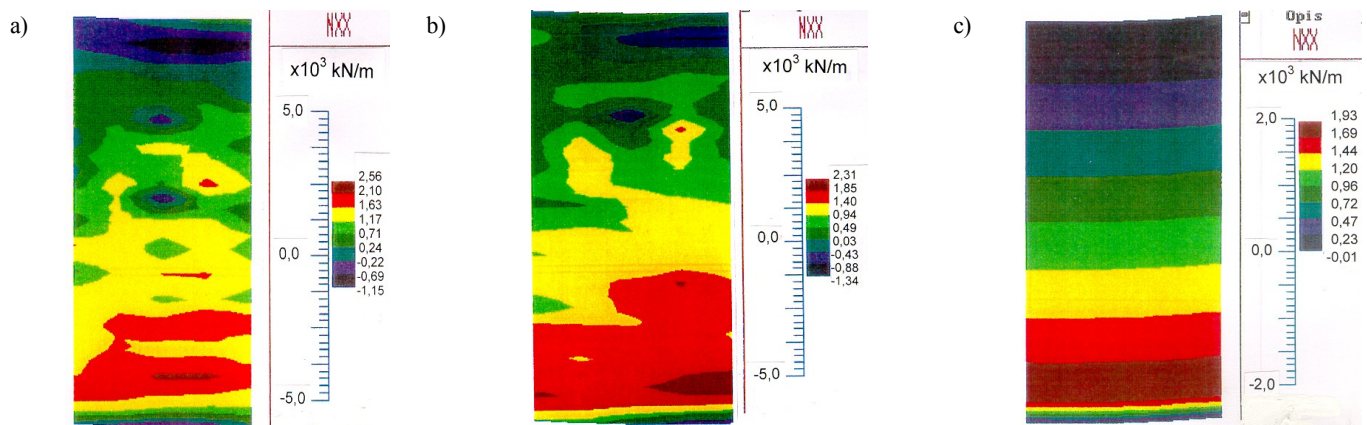

Fig. 7. Comparison of circumferential stretching forces in the shell a), b) with imperfections, c) ideal

The stress values obtained in the tests were compared with the values calculated for an ideal (ideally shaped) tank. This comparison is presented on a graph (fig. 8). On the basis of the comparison of measured and calculated stress values, it was found that the shape deformation of the shell considerably alters the local stress values calculated for the ideal shell shape.

The results obtained on the second measuring plumb-line on the fifth level can be a clear example of this. There, the stress values were more than twice as high as the expected values (258 %). The values obtained in computer calculations with the utilisation of finished elements method for deformed shells are not satisfactory and therefore they have not been presented in this paper.

The reason for such a poor match of the computer calculations may be either a poor convergence of the calculation process or a poor match of the characteristic of the elements used for modelling the shell. Therefore, further attempts have been made with the utilisation of another system of modelling and software in order to find a satisfactory relationship between the values of imperfection and the resulting change of stress values.

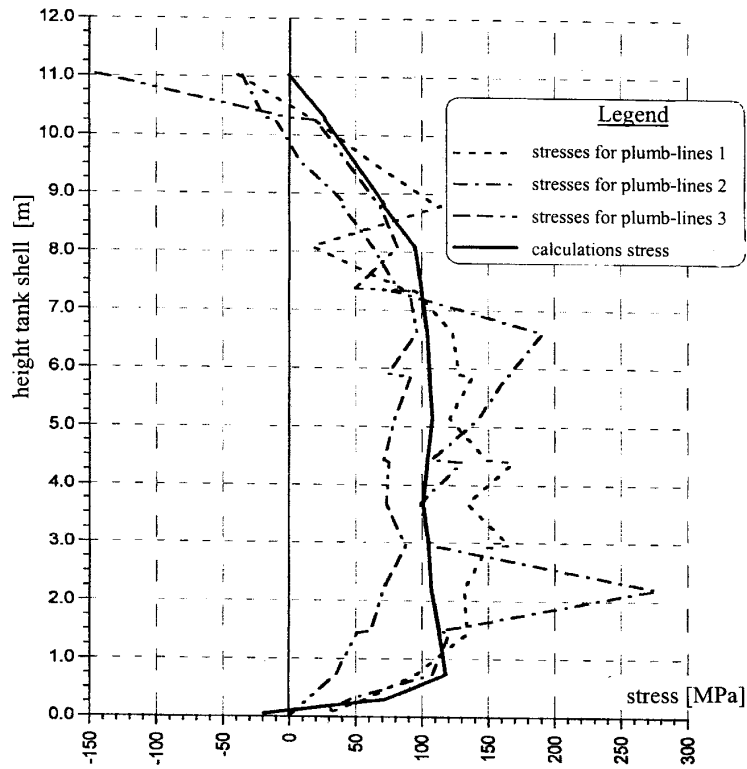

Fig. 8. Comparison of measured and calculated stress values

SUMMARY

Considerable imperfections of cylindrical shells can result in a substantial change in the local stress state in the tank shell. If added up, the stress connected with imperfections, the welding stress and welding flaws can do damage to the construction, an example of which is the cracking of welded butts of the tank shells. On that account, a stricter supervision should be introduced in the construction period and the values of permissible deviation included in standards e.g. PN-B-3010:1997 - Steel constructions. Vertical cylindrical tanks for liquids. Projects and realisations - need to be reduced.

REFERENCES

- [1] Ziółko J.: Repairs with the utilisation of welding in operating steel tanks with floating roofs. Scientific Technical Conference 'Metal Constructions' Gdańsk 1989, Poland.
- [2] Ziółko J.: Imperfections of cylindrical steel tanks – reasons, ways of limiting 'Engineering and Building', no 11/1999.
- [3] Kowalski D.: Qualitative and quantitative assessment of deviation in the construction of steel tanks. Scientific Technical Conference. 'Operational problems of kerosene products warehouses' – Poznań 1999, Poland.