

## *Elastyczne procesy logistyczne z wykorzystaniem modułowych jednostek ładunkowych*

Bogusz WIŚNICKI, Tygran DZHUGURYAN

**Abstract:** The aim of the article is to present an innovative concept of modular load units which increase the efficiency of production processes as well as transport and logistics. The characteristic of the original concept of modular load units are presented, with their technical and technological description and assembly. The article ends with a synthetic analysis of the effectiveness of the proposed solutions. The applications contain a description of the possibilities of further implementation and development of the technology under study.

**Keywords:** flexible logistic, modular loading units, collapsible container

**Streszczenie:** Celem artykułu jest przedstawienie innowacyjnej koncepcji modułowych jednostek ładunkowych, zwiększających efektywność procesów produkcyjnych i transportowo-logistycznych. Przedstawiono charakterystykę autorskiej koncepcji modułowych jednostek ładunkowych, z ich opisem techniczno-technologicznym i montażowym. Artykuł kończy się syntetyczną analizą efektywności proponowanego rozwiązania. Wnioski zaś zawierają opis możliwości dalszej implementacji i rozwoju badanej technologii.

**Kluczowe słowa:** logistyka elastyczna, modułowe jednostki ładunkowe, kontener składany

### Introduction

Application of loading units in production and transport allows to achieve the benefits by increasing security and reducing logistics costs. Loading unit is understood in this case, as the consolidated packaging adapted to mechanization of internal and external transport processes. The condition for the benefit is an appropriate choice of units, so as to meet the matching requirements for cargo carried as well as means of transport and handling equipment. A chosen loading unit should have sufficient cargo capacity, taking into account the volume and the weight, should be resistant to the transportation forces [1]. With this in mind, the most common choice are the standard units: containers (ISO standard) or swap bodies (CEN standard) that allow transloading between different modes of transport [2]. Containers are designed primarily for maritime transport and swap bodies work well in rail-road transport. Standardization of these units is an advantage but also an important constraint. These restrictions are as the following [3, 4]:

- 1) inability to use units other than the standard dimensions (e.g. 20', 30', 40' or 45' of length for containers);
- 2) impossibility of folding and unfolding units (except for very niche types of containers that are several times more expensive than the standard ones);
- 3) no possible flexible changes in units' parameters according to the current demand;
- 4) lack of the possibility to change the strength factor or core functionality of the units.

The concept of modular loading unit meets these needs. They create a solution fully flexible and easy to

assemble. The essence of this solution are standard modules which form the basis of the structure of units instead of standard loading units. This approach is accompanied by the author's versatile and easy-to-implement the system of combining individual modules.

The following chapters are dedicated to description of the construction of modular loading containers along with their assembling system. Further, the effectiveness analysis of the proposed solution of the benefits is formulated and the potential applications in logistic systems are determined.

### Design of modular container

The collapsible modular container consists of two types of unified frame modular loading units fulfilling the value of the load-carrying structure (Figure 1, a) and the functional structure (Figure 1, b). The load-carrying structure of the modular loading units is ensuring the stiffness and strength of the container structure, allows strengthening its structure in the most loaded places. The functional structure of the modular loading units is providing the sufficient strength and rigidity of the container structure along with the possibility of convenient access to the transported goods at the loading and unloading stage. The internal sizes of the functional modular loading units are determined by the sizes of the loading pallets with the outgoing freight. Four standard sizes of the modular loading units of both types are proposed: the largest standard size is 1500x1500 mm overall, two intermediate standard sizes are 1000x1500 mm and 1000x1000 mm overall, and the smallest standard size is 700x1000 mm overall. The choice of

standard size of the module loading units is depended on the goods carried and their dimensions, as well as on the loading and unloading mechanisms and vehicles used.

The modular loading units of load-carrying and functional structure can form various configurations of collapsible modular containers depending on the type and parameters of the outgoing freight. Figure 2 shows the schemes of possible layout of the modular loading units with load-carrying and functional structure in the collapsible container. The schemes for layouts of the modular loading units with load-carrying structure in the collapsible container can be conditionally designated as the "X" scheme (Figure 2, a) and the "O" scheme (Figure 2, b). The choice of a rational scheme for the modular loading units' layout is determined on the basis of the container structure for stresses and strains analysis, considering the transported freight.

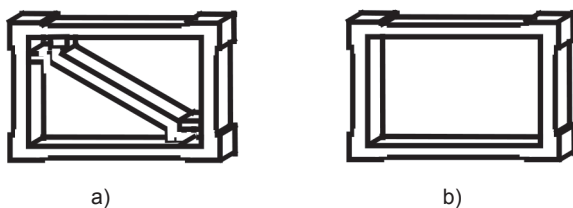

Fig. 1. The unified frame modular loading units with load-carrying structure (a) and with functional structure (b)  
Rys. 1. Standardowe profile konstrukcyjne modułowych jednostek ładunkowych: a) o zwiększonej wytrzymałości, b) o zwykłej wytrzymałości

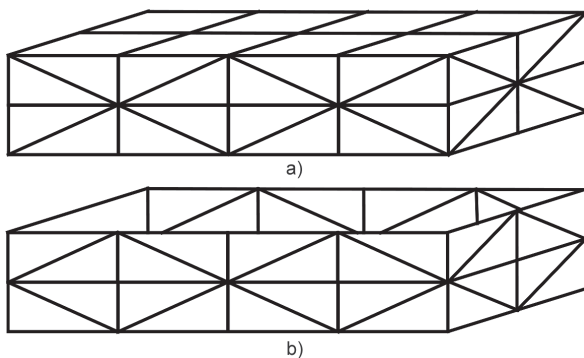

Fig. 2. Schemes of possible layout of the modular loading units with load-carrying and functional structure in the collapsible container: a) scheme "X" b) scheme "O"  
Rys. 2. Schematy budowy modułowych jednostek ładunkowych, złożonych z profili o zwykłej i zwiększonej wytrzymałości: a) wzorzec „X”, b) wzorzec „O”

For the freight transportation are used two types of containers: heavy containers with a carrying capacity up to 30 tons and light containers for carriage high volume cargoes.

The heavy container is assembled on a load-carrying platform with fittings, by means of which a crane carries out its loading on a vehicle. The lower row of the

container along its perimeter is made of the load-carrying modular loading units. The functional modular loading units are partly used in the upper row to support a protective cover made of tarpaulins or plastic material. Standard overall dimensions of container with the platform: length up to 12000 mm, width up to 2500 mm, height without freight up to 1700 mm, however with freight of up to 3000 mm.

The lightweight container for bulk freight is made of load-carrying modular loading units that can be mounted in two rows on a separate load-carrying platform or on a frame of longitudinal and transverse beams. The windows in the modular loading units are covered with protective metal or plastic sheets to prevent the self-emptying of the freight from the container. A feature of the container for bulk freight is the possibility of its self-unloading as a result of its tilt by the lifting mechanism of the vehicle with the subsequent return to its original position. For this, one of the walls (usually the end wall) is fixed in the upper part on hinges and is locked in the closed position using locking devices and finger fasteners.

For transportation of liquid freight, a frame or cellular frame container is used. The frame container for liquid freight is assembled from the load-carrying modular loading units. A metal or plastic tank is permanently installed inside it. The cellular frame container for liquid freight is assembled from load-carrying and functional modular loading units, in the cells of which there are removable tanks. Loading and unloading of the tanks takes place through the windows of functional modules loading units. Like a cellular frame container for liquid freight, a container for transportation freight in packaging is designed with the only difference that instead of tanks with liquid the freight on pallets inside the cells are placed (Figure 3).

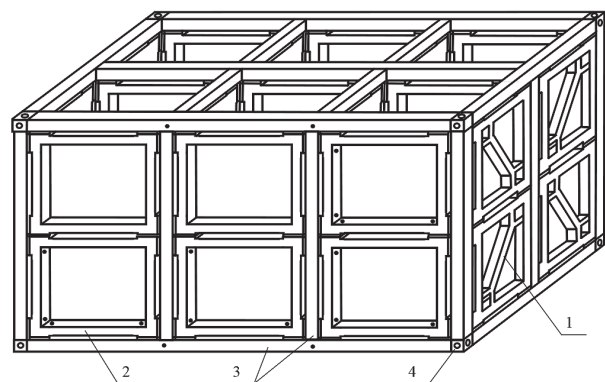

Fig. 3. Scheme of the cellular frame container for transportation freight in packaging: 1) load-carrying modular loading units, 2) functional modular loading units, 3) beams of the container frame, 4) fittings

Rys. 3. Schemat budowy kontenera z profili do przewozu ładunków drobnicowych: 1) profile o zwiększonej wytrzymałości, 2) profile o zwykłej wytrzymałości, 3) belki ramy kontenerowej, 4) naroża

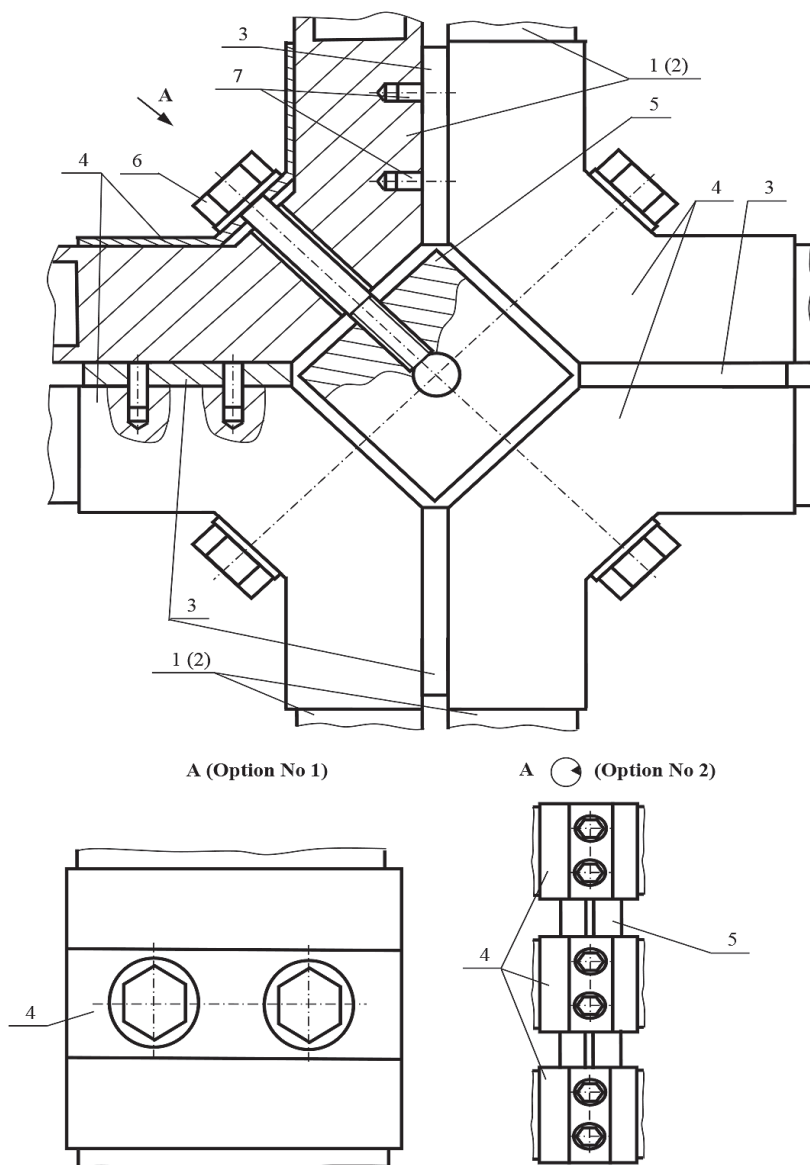

Fig. 4. Scheme of connection the load-carrying or functional modular loading units among themselves without an intermediate frame of the container: 1 (2) – load-carrying (functional) modular loading units, 3 – wiring strip, 4 – clamps, 5 – mounting foot, 6 – bolts with lock washers, 7 – stop pins

Rys. 4. Schemat połączenia profili o zwiększonej i zwykłej wytrzymałości bez użycia ramy kontenera: 1 (2) – profil o zwiększonej (zwykłej) wytrzymałości, 3 – przekładka kompensacyjna, 4 – nakładka zaciskowa, 5 – stopka montażowa, 6 – śruby z podkładkami, 7 – pin mocujący

### Assembling process

The containers of the load-carrying and functional modular loading units are assembled using bolted connections. Figure 4 shows example of the load-carrying or functional modular loading units connected without an intermediate frame of the container.

Figure 5 shows examples of the load-carrying or functional modular loading units connecting with intermediate beams of the container frame or the supporting platform of the container.

The choice the module loading units' material and the technology of their manufacturing depends on the weight

of the transported freight, the overall dimensions of the container and the standard size of the module loading units. For example, the module loading units of the heavy containers of large overall dimensions are made of steel. The module loading units of light containers can be manufactured from light metal alloys, for example, aluminium alloys, as well as from plastics or carbon plastics materials. The choice of manufacturing technology for the module loading units is depending by their standard sizes. Large standard size of the metal module loading units is expedient to manufacture by a method of casting, and for the manufacture of small standard size of the module loading units it is possible to use additive technologies.

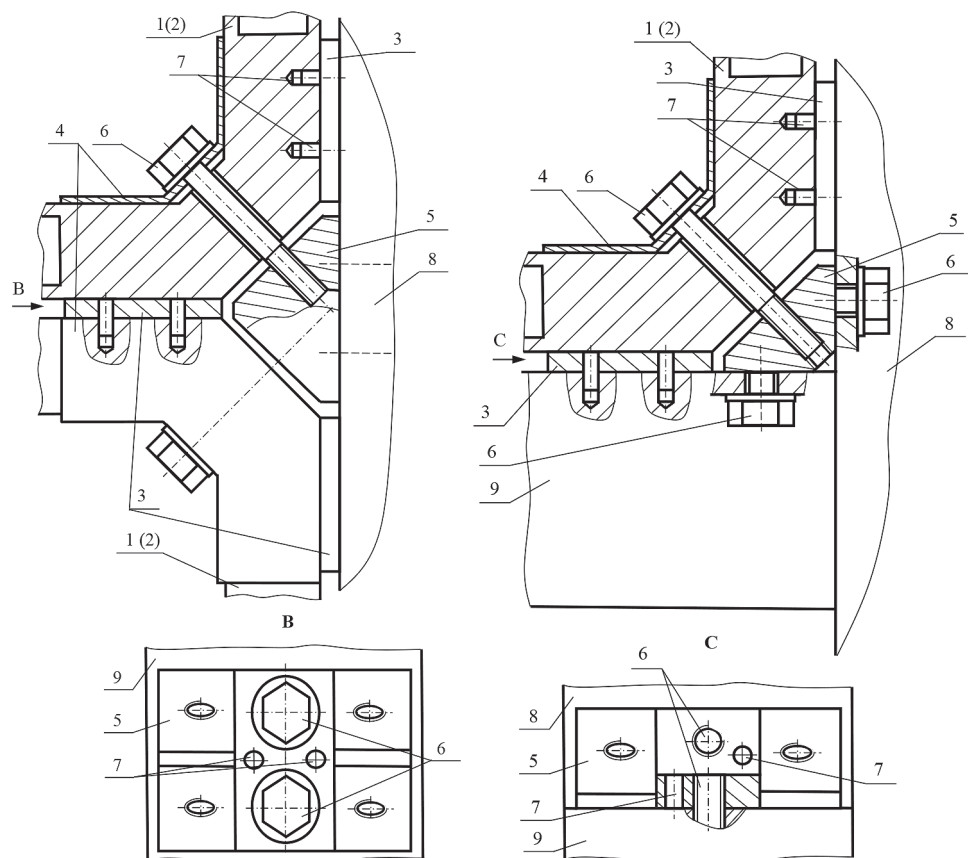

Fig. 5. Scheme of connection the load-carrying or functional modular loading units with intermediate beams of the container frame or the supporting platform of the container: 1 (2) – load-carrying (functional) modular loading units, 3 – wiring strip, 4 – clamps, 5 – mounting foot, 6 – bolts with lock washers, 7 – stop pins, 8 – vertical beam of the container frame, 9 – horizontal beam of the container frame or the supporting platform of the container

Rys. 5. Schemat połączenia profili o zwiększonej i zwykłej wytrzymałości z użyciem ramy kontenera: 1 (2) – profil o zwiększonej (zwykłej) wytrzymałości, 3 – przekładka, 4 – klamra, 5 – stopka montażowa, 6 – śruby z podkładkami, 7 – bolec mocujący, 8 – belka pionowa ramy kontenera, 9 – belka pozioma ramy kontenera lub platforma podłogi kontenera

Table 1. Comparative analysis of standard and non-standard loading units

Tabela 1. Analiza porównawcza standardowych i niestandardowych jednostek ładunkowych

Category	Loading unit				
	Container	Collapsible containers	Swap body	Logistics units	Modular container
Standard	ISO	ISO	CEN	no	no
Parameters	20', 30', 40', 45'	20', 30', 40', 45'	2 types: long and short	any	any
Loading capacity	up to 35t	less than 35t	30t	any	any
Types of constructions	many types adjusted to cargo type	1-2 types	1-5 types	adjusted to needs	adjusted to needs
Stackable	yes	yes (limited)	strengthen types	possible	possible
Flexibility in construction	no	option to fold down	no	no	many options, tailor mad solutions
Implementation	sea transport, intermodal transport	sea transport, intermodal transport	intermodal transport	warehouse or dedicated transport	warehouse or dedicated transport
Coverage	global	niche connections	Europe	niche connections	not determined

## Analysis of functional efficiency

Determination of the efficiency of the described technology solution at the present stage of its implementation is very difficult. One must first perform a prototype and test it in real operating conditions [5]. Even though a comparative analysis of modular container with existing on the market standard and custom loading units (Table 1).

Table 1 shows the advantages and disadvantages of the various loading units in terms of technical and exploitation features. It allows determining their relative functional efficiency. Flexibility and the variety of applications features the modular containers. Unknown is currently demand for this technical solution, but it can be assumed that it will be a complementary solution to standard loading units.

## Conclusions

The use of the modular loading units for the manufacturing of collapsible containers can reduce the time and costs for: their design, installation, dismantling, re-equipment and disposal, enabling efficient in-house logistics. The process of assembling the container does not require special equipment and can be carried out on allocated for these purposes assembly areas, and on any free areas in the manufacturing or warehousing locations. This contributes to the formation of flexible logistics processes in the organization of transport and warehouse systems by increasing the efficiency of creating or re-equipping the required types, overall dimensions and configurations of containers. The framework of the proposed modular loading units can be much wider and not limited to collapsible containers. For example, the proposed modular loading units can be used in building structures, in the machine tool industry, in the manufacture of flexible manufacturing modules in frame construction [6], in the multi-floor manufacturing systems as the load-carrying and functional modular units of trolleys intended for the transport and storage of components and finished products [7, 8 and 9].

## REFERENCES

[1] Rzczycki A., B. Wiśnicki. 2016. "Strength Analysis of Shipping Container Floor with Gooseneck Tunnel

under Heavy Cargo Load". *Solid State Phenomena*, Vol. 252, 2016, p. 81–90.

- [2] Wiśnicki B., A. Dyrda. 2016. "Analysis of the intermodal transport efficiency in the Central and Eastern Europe, Naše More". *International Journal of Maritime Science & Technology*, 63 (2) p. 43–47.
- [3] Vademecum konteneryzacji – Formowanie kontenerowej jednostki ładunkowej, monografia pod redakcją Bogusza Wiśnickiego, Wydawnictwo Link I, Szczecin 2006, p. 392.
- [4] Chwesiuk K., I. Kotowska, B. Wiśnicki. 2008. „Perspektywy przewozów intermodalnych w Polsce”. Wydawnictwo Naukowe Akademii Morskiej w Szczecinie.
- [5] Wiśnicki B. 2010. "Uwarunkowania obsługi kontenerów 45-stopowych w portach europejskich" [w:] *Polska gospodarka morska – Restrukturyzacja. Konkurencyjność. Funkcjonowanie. Rozwój*, redakcja naukowa Henryka Salmonowicza, Wydawnictwo Kreos, Szczecin, s. 385–395.
- [6] Dzhuguryan T. 2012. "Design Features of Flexible Manufacturing Modules in Frame Construction". *Zeszyty Naukowe Politechniki Rzeszowskiej. Mechanika, Oficyna Wydawnicza Politechniki Rzeszowskiej*, z. 84 [284] (1): 21–25.
- [7] Dzhuguryan T., Z. Józwiak. 2016. "Infrastructure for multi-floor virtual enterprises system". *Systemy wspomaganie w inżynierii produkcji*, P.A. Nowa S.A. Gliwice, 3 (15): 70–78.
- [8] Dzhuguryan T., Z. Józwiak. 2017. "Specific approach to assessment of technologies for multi-floor manufacturing system". *Autobusy: technika, eksploatacja, systemy transportowe* (6): 1656–1659.
- [9] Dzhuguryan T., Z. Józwiak. 2016. "Improving the logistics of the multi-floor assembly manufacturing". *Technologia i Automatyzacja Montażu* (2): 16–20.

**The research was carried out under a grant of the Ministry of Science and Higher Education of Poland at the Faculty of Transport Engineering and Economics of the Maritime University of Szczecin**

dr inż. Bogusz Wiśnicki – Akademia Morska w Szczecinie, ul Wały Chrobrego 1-2 Szczecin, e-mail: b.wsnicki@am.szczecin.pl

prof. dr hab. inż. Tygran Dzhuguryan – Akademia Morska w Szczecinie, ul Wały Chrobrego 1-2 Szczecin, e-mail: t.dzhuguryan@am.szczecin.pl